



The Corporation of the City of Sault Ste. Marie  
Regular Meeting of City Council  
Agenda

Monday, June 19, 2023

4:30 pm

Council Chambers and Video Conference

Meetings may be viewed live on the City's YouTube channel  
<https://www.youtube.com/user/SaultSteMarieOntario>

---

	Pages
<b>1. Land Acknowledgement</b>	
I acknowledge, with respect, that we are in Robinson-Huron Treaty territory, that the land on which we are gathered is the traditional territory of the Anishinaabe and known as Bawating. Bawating is the home of Garden River First Nation, Batchewana First Nation, the Historic Sault Ste. Marie Metis Council.	
<b>2. Adoption of Minutes</b>	17 - 44
Mover Councillor S. Spina Secunder Councillor C. Gardi Resolved that the Minutes of the Regular Council Meeting of May 29, 2023 be approved.	
<b>3. Questions and Information Arising Out of the Minutes and not Otherwise on the Agenda</b>	
<b>4. Declaration of Pecuniary Interest</b>	
<b>4.1 Mayor M. Shoemaker – A-3-23-Z. OP 352/360 Northern Avenue &amp; 31 Old Garden River Road (Cara Community Corporation)</b>	
<b>5. Approve Agenda as Presented</b>	
Mover Councillor S. Spina Secunder Councillor C. Gardi	

Resolved that the Agenda for June 19, 2023 City Council Meeting as presented be approved.

**6. Proclamations/Delegations**

**6.1 Mayor for a Day**

Cassianna Somme

**6.2 OLG Community Recognition Cheque Presentation**

Esther Zdolec, SVP People & Culture, OLG

**6.3 Algoma Steel Update**

Michael Garcia, CEO, Algoma Steel

**7. Communications and Routine Reports of City Departments, Boards and Committees – Consent Agenda**

Mover Councillor S. Spina

Seconder Councillor M. Scott

Resolved that all the items listed under date June 19, 2023 – Agenda item 7 – Consent Agenda be approved as recommended.

**7.1 Correspondence – Rural and Northern Immigration Pilot Program**

45 - 66

Correspondence to Minister of Immigration, Refugees and Citizenship from:

- Mayor Shoemaker
- Algoma Steel Inc.
- Tenaris Algoma Tubes
- Sault Area Hospital
- Tulloch
- N1 Solutions
- F.J. Davey Home
- Ontario's North Economic Development Corporation
- Sault Ste. Marie Chamber of Commerce
- PLATO Testing
- MicroAge Technical Services Ltd.
- Chartwell Collegiate Heights Retirement Home
- Chuck's Roadhouse Bar and Grill
- Northern Ontario Large Urban Mayors

- Soo Foundry & Machine
- JD Aero
- Delta Hotels by Marriott Sault Ste. Marie

- 7.2 Rotaryfest 2023** 67 - 67
- Correspondence from Rotary Club of Sault Ste. Marie is attached for the consideration of Council.
- The relevant By-law 2023-96 is listed under Agenda item 12 and will be read with all by-laws under that item.
- 7.3 2024 Budget Schedule** 68 - 69
- A report of the Chief Financial Officer and Treasurer is attached for the consideration of Council.
- Mover Councillor S. Spina  
Seconder Councillor M. Scott  
Resolved that the report of the Chief Financial Officer and Treasurer dated June 19, 2023 concerning the 2024 Budget Schedule be received as information.
- 7.4 RFP – Engagement of an Integrity Commissioner for the City of Sault Ste. Marie** 70 - 71
- A report of the Manager of Purchasing is attached for the consideration of Council.
- The relevant By-law 2023-95 is listed under Agenda item 12 and will be read with all by-laws under that item.
- 7.5 Asset Management Plan Phase II Non-Core Assets** 72 - 73
- A report of the Manager of Purchasing is attached for the consideration of Council.
- The relevant By-law 2023-99 is listed under Agenda item 12 and will be read with all by-laws under that item.
- 7.6 Refuse Truck Rental Extension – Public Works Waste Management** 74 - 75
- A report of the Manager of Purchasing is attached for the consideration of Council.
- Mover Councillor S. Spina  
Seconder Councillor C. Gardi  
Resolved that the report of the Manager of Purchasing dated June 19, 2023 concerning rental of refuse truck as required by Public Works Waste

Management Division be received and that extension of the rental from July to December 2023 for the additional amount of \$70,800 (plus HST) be approved.

**7.7 Tender for Firefighter Bunker Gear 76 - 78**

A report of the Manager of Purchasing is attached for the consideration of Council.

Mover Councillor S. Spina

Seconder Councillor C. Gardi

Resolved that the report of the Manager of Purchasing dated June 19, 2023 concerning Firefighter Bunker Gear be received and that the tender of A.J. Stone Company Limited of \$295,920 (HST extra) be approved.

**7.8 Property Tax Appeals – June 2023 79 - 81**

A report of the Manager of Taxation is attached for the consideration of Council.

Mover Councillor S. Spina

Seconder Councillor M. Scott

Resolved that the report of the Manager of Taxation dated June 19, 2023 concerning Property Tax Appeals be received and that the recommended amendments to tax records pursuant to section 357 of the *Municipal Act, 2001* be approved, including the denial of one application.

**7.9 Registration of Tax Arrears Certificate(s) and Sale 82 - 84**

A report of the Manager of Taxation is attached for the consideration of Council.

Mover Councillor S. Spina

Seconder Councillor M. Scott

Resolved that the report of the Manager of Taxation dated June 19, 2023 be received and Council authorize the Manager of Taxation to commence Tax Sale proceedings as listed in the attached schedule be commenced in accordance with the *Municipal Act, 2001*.

**7.10 Memorandum of Settlement for CUPE 67 Civic Centre 85 - 124**

A report of the Labour Relations Coordinator is attached for the consideration of Council.

Mover Councillor S. Spina

Seconder Councillor C. Gardi

Resolved that the report of the Labour Relations Coordinator dated June 19, 2023 be received and that City Council ratify the Memorandum of Settlement for CUPE Local 67 – Civic Centre.

- 7.11 Memorandum of Settlement ATU Local 1767** 125 - 189
- A report of the Labour Relations Coordinator is attached for the consideration of Council.
- Mover Councillor S. Spina  
Seconder Councillor M. Scott  
Resolved that the report of the Labour Relations Coordinator dated June 19, 2023 concerning Memorandum of Settlement for Amalgamated Transit Union (ATU) Local 1767 be received and that Council ratify the Memorandum of Settlement.
- 7.12 Mill Market Agreement** 190 - 191
- A report of the Deputy CAO – Community Development and Enterprise Services is attached for the consideration of Council.
- The relevant By-law 2023-94 is listed under item 12 of the Agenda and will be read with all by-laws under that item.
- 7.13 Delegated Authority for Tourism Development Fund Agreements** 192 - 194
- A report of the Director of Tourism and Community Development is attached for the consideration of Council.
- The relevant By-law 2023-101 is listed under Agenda item 12 and will be read with all by-laws under that item.
- 7.14 Long-term Funding Requirements – Entomica Insectarium** 195 - 199
- A report of the Director of Tourism and Community Development is attached for the consideration of Council.
- Mover Councillor S. Spina  
Seconder Councillor M. Scott  
Resolved that the report of the Director Tourism and Community Development dated June 19, 2023 be received and that Council refer Entomica’s request for \$137,276 in annual funding to 2024 budget deliberations.
- 7.15 Request to Rename Snowdon Park** 200 - 203
- A report of the Manager of Recreation and Culture is attached for the consideration of Council.
- Mover Councillor S. Spina  
Seconder Councillor C. Gardi  
Resolved that the report of the Manager of Recreation and Culture dated June 19, 2023 concerning Request to Rename Snowdon Park be received and the recommendation of the Parks and Recreation Advisory Committee that the

Snowdon Park name remain and a memorial area in the northwest of the park be named "Every Child Matters Sacred Memorial" be approved.

**7.16 Sault Ste. Marie Museum Window Project Agreement 204 - 205**

A report from the Manager of Recreation and Culture is on the Agenda.

The relevant By-law 2023-106 is listed under item 12 of the Agenda and will be read with all by-laws under that item.

**7.17 Community Development Fund – Green Initiatives Program Applications June 2023 206 - 209**

A report of the Sustainability Coordinator is attached for the consideration of Council.

Mover Councillor S. Spina

Seconder Councillor C. Gardi

Resolved that the report of the Sustainability Coordinator dated June 6, 2023 concerning Community Development Fund – Green Initiatives Program Applications June 2023 be received and that the recommendations of the Environmental Sustainability Committee to support the following be approved:

1. City of Sault Ste. Marie Tourism Department "Clear Your Gear" project funding in the amount of \$1,750;
2. City of Sault Ste. Marie Community Development and Enterprise Services Civic Centre Electric Vehicle Charging project funding in the amount of \$16,050; and
3. Sault Ste. Marie Innovation Centre Trapping the Flow project funding in the amount of \$6,975.62.

**7.18 Curb and Sidewalk Program 2023 210 - 216**

A report of the Director of Public Works is attached for the consideration of Council.

Mover Councillor S. Spina

Seconder Councillor M. Scott

Resolved that the report of the Director of Public Works dated June 19, 2023 concerning the 2023 Curb and Sidewalk Program be received as information.

**7.19 Rail Crossing Decommissioning – Carmen's Way North of Conmee Avenue 217 - 218**

A report of the Municipal Services and Design Engineer is attached for the consideration of Council.

Mover Councillor S. Spina

Seconder Councillor M. Scott

Resolved that the report of the Municipal Services and Design Engineer dated

June 19, 2023 concerning Rail Crossing Decommissioning be received and that Council support the decommissioning of the rail crossing at Carmen's Way north of Conmee Avenue.

**7.20 Contract 2023-8E Carmen's Way Resurfacing 219 - 220**

A report of the Municipal Services and Design Engineer is attached for the consideration of Council.

The relevant By-law 2023-102 is listed under item 12 of the Agenda and will be read with all by-laws under that item.

**7.21 Fire Services By-Law Updates 2023 221 - 222**

A report of the Fire Chief is attached for the consideration of Council.

The relevant By-laws 2023-97 and 2023-98 are listed under Agenda item 12 and will be read with all by-laws under that item.

**7.22 Update – Vacant Building Enforcement and Proposed By-Law and Amendments 223 - 225**

A report of the Solicitor is attached for the consideration of Council.

The relevant By-laws By-laws 2023-108, 2023-109, and 2023-110 are listed under item 12 of the Agenda and will be read with all by-laws under that item.

**8. Reports of City Departments, Boards and Committees**

**8.1 Administration**

**8.1.1 CAO Recruitment Next Steps 226 - 231**

A report of the CAO is attached for the consideration of Council.

Mover Councillor S. Spina

Secunder Councillor C. Gardi

Resolved that the report of the CAO dated June 19, 2023 concerning CAO Selection Process be received and that the following recommendations be approved:

1. That the revised policy Recruitment and Selection of Senior Staff be approved;
2. That Council authorize the filling of the upcoming vacancy of the Chief Administrative Officer;
3. That Mayor Shoemaker and Councillors \_\_\_\_\_ and \_\_\_\_\_ be appointed to the CAO Selection Committee.

**8.2 Corporate Services**

**8.3 Community Development and Enterprise Services**

**8.4 Public Works and Engineering Services**

**8.5 Fire Services**

**8.6 Legal**

**8.7 Planning**

**8.7.1 A-2-23-Z.OP 1692 Peoples Road (Luke Barban)**

232 - 247

Mover Councillor S. Spina

Seconder Councillor C. Gardi

Resolved that the report of the Junior Planner dated June 19, 2023 concerning application A-2-23-Z.OP be received and that Council approve this application subject to the following provisions:

1. Approve Official Plan Amendment No. 246 by way of a notwithstanding clause to Section 2.3.6, to permit a Carpentry Contractor's Yard;
2. Rezone the subject property from Rural Aggregate Extraction Zone (REX) to Rural Aggregate Extraction Zone (REX.S) with a special exception to permit, in addition to the uses currently permitted in an REX zone, a Carpentry Contractor's Yard subject to the following provisions:
  - a. Reduce the required interior (south) side yard setback from 30m to 2m for the existing scale house only;
  - b. Reduce the required interior side yard setbacks from 30m to 5m;
  - c. Reduce the required front yard setback from 30m to 25m; and
  - d. Permit outdoor storage and accessory use freight containers on the subject property subject to the provision that they not encroach into the required front or the required side yards.
3. Deem the subject property as an area of Site Plan Control.

And that the Legal Department be requested to prepare the necessary by-law(s) to effect the same.

**8.7.2 A-3-23-Z. OP 352/360 Northern Avenue & 31 Old Garden River Road (Cara Community Corporation)**

248 - 310

Mayor M. Shoemaker declared a conflict on this item.

Mover Councillor S. Spina

Seconder Councillor M. Scott

Resolved that the report of the Junior Planner dated June 19, 2023



concerning Rezoning Application A-3-23-Z.OP be received and that Council:

1. Approve Official Plan Amendment 247, by way of a notwithstanding clause to Policies R.7 and C.4 to permit up to 750m<sup>2</sup> of commercial development, including major office space, upon the subject property.
2. Rezone the subject area from High Density Residential Zone (R5.S-405) with Special Exception 405 to High Density Residential Zone (R5.S) with a new Special Exception to permit, in addition to the uses already permitted in an R5 zone, up to 750m<sup>2</sup> of commercial space, subject to the following provisions:
  - a. Permitted commercial uses include office uses, food services, personal services, retail trade, amusement and fitness facilities, arts culture and heritage uses, bingo halls, accessory uses and similar. The foregoing uses are subject to the same regulations as the proposed apartment building;
  - b. Reduce the required east interior side yard setback to from 13.5m to 0m to accommodate an enclosed corridor between the proposed building and the existing building on the abutting property;
  - c. Reduce the combined number of required parking spaces from 185 to 101 spaces for the proposed 108-unit apartment building, the existing 4-unit multiple attached dwellings, the place of worship, and the commercial use of the property;
  - d. Provide a minimum of nine barrier-free parking spaces;
  - e. Reduce the west exterior side yard setback from 13.5m to 4m;
  - f. Permit parking within the required front (south) and exterior (west) side yards;
  - g. Waive the need to provide a dedicated loading space as required by Section 6 of the Zoning By-Law; and
  - h. Reduce the required landscaped open space from 33% to 29%.

The relevant By-laws 2023-104 and 2023-105 are listed under Agenda item 12 and will be read with all by-laws under that item.

## **8.8 Boards and Committees**

### **8.8.1 Police Services Board Appointment**

Councillor S. Hollingsworth and Councillor S. Spina have indicated an interest in serving on this board.

Mover Councillor L. Vezeau-Allen

Seconder Councillor M. Scott

Resolved that Councillor \_\_\_\_\_ be appointed to the Police Services Board from June 19, 2023 to December 31, 2024.

**9. Unfinished Business, Notice of Motions and Resolutions Placed on Agenda by Members of Council**

**9.1 Bear Train**

Mover Councillor L. Vezeau-Allen

Seconder Councillor M. Scott

Whereas the Algoma Central Railway passenger train service between Sault Ste. Marie and Hearst was discontinued in 2014 when the federal government determined it no longer qualified under the Remote Passenger Rail Program; and

Whereas this essential service supported significant economic, employment and tax generation; and

Whereas as a result of the cessation of this service eight years ago (in July 2015), access has been denied to, and caused substantial hardships for, many First Nations people, municipalities, businesses, trappers, forestry workers, miners, and residents; and,

Whereas passenger train service is necessary for First Nations people to access remote regions of their traditional territories, including spiritually significant locations; and

Whereas Missanabie Cree First Nation, under the leadership of Chief Jason Gauthier, has worked diligently to ensure the passenger train service known as the Bear Train along the ACR line will be reinstated, and this will demonstrate efforts towards reconciliation and provide employment and economic opportunities for Indigenous people and others; and

Whereas Mask-wa Transportation Association Inc., a provincial corporation initiated by Missanabie Cree First Nation has prepared a comprehensive business case to take to funders, which will soon be updated with current financial data; and

Whereas 75% of properties in proximity to the rail line are inaccessible except by passenger train service, and the passenger train has been the only safe, legal, all-season, affordable access into the Algoma wilderness rail corridor for over 108 years; and

Whereas a study completed in 2014 by BDO Canada concluded that the Algoma passenger train is in the public interest in that it supported:

- \$38-\$48 million in annual economic impact
- 170-220 jobs
- \$5.12-\$6.45 million in annual tax generation

Now Therefore Be It Resolved that Sault Ste. Marie City Council supports the Missanabie Cree First Nation and the Mask-wa Transportation Association Inc. in the development of the Mask-wa Oo-ta-ban (the Bear Train) and are

committed to working closely with Missanabie Cree First Nation on this initiative, a much-needed transportation alternative for Sault Ste. Marie, a major northern transportation hub; and

Further Be It Resolved that City Council recognizes that Sault Ste. Marie is missing out on significant tourism and related business opportunities without a passenger train service along the ACR line and that major efforts will need to be made by all levels of government to bring back and enhance this major tourist attraction; and

Further Be It Resolved that Sault Ste. Marie City Council will approach the Governments of Canada and Ontario to request subsidization of the ongoing operation of the Mask-wa Oo-ta-ban (Bear Train); and

Further Be It Resolved that Sault Ste. Marie City Council supports Mask-wa Transportation Association Inc.'s request that both the federal and provincial governments formally recognize the passenger rail service and the rail access corridor it serves as a unique and valuable cultural, historic, recreational, environmental and economic asset; and

Further Be It Resolved that a copy of this resolution motion be distributed to Prime Minister Justin Trudeau, Minister of Transport Omar Alghaba, Minister of Indigenous Services Patti Hajdu, Premier Doug Ford, Minister of Transportation Caroline Mulroney, Minister of Indigenous Affairs Greg Rickford, MP Terry Sheehan, MP Carole Hughes, MPP Ross Romano, and MPP Michael Mantha

**10. Committee of the Whole for the Purpose of Such Matters as are Referred to it by the Council by Resolution**

**11. Adoption of Report of the Committee of the Whole**

**12. Consideration and Passing of By-laws**

Mover Councillor S. Spina

Seconder Councillor C. Gardi

Resolved that all By-laws under item 12 of the Agenda under date June 19, 2023 be approved.

**12.1 By-laws before Council to be passed which do not require more than a simple majority**

**12.1.1 By-law 2023-94 (Agreement) Mill Market Lease**

311 - 367

A report from the Deputy CAO is on the Agenda.

Mover Councillor S. Hollingsworth

Seconder Councillor C. Gardi

Resolved that By-law 2023-94 being a by-law to authorize the execution of

the Agreement between the City and Mill Market Sault Ste. Marie for a lease agreement for the Mill Market be passed in open Council this 19th day of June, 2023.

**12.1.2 By-law 2023-95 (Agreement) Integrity Commissioner Services (Ironsides Consulting Services Inc.) 368 - 413**

A report from the Manager of Purchasing is on the Agenda.

Mover Councillor S. Spina

Seconder Councillor C. Gardi

Resolved that By-law 2023-95 being a by-law to authorize the execution of the Agreement between the City and Ironsides Consulting Services Inc. to provide Integrity Commissioner Services for the City of Sault Ste. Marie be passed in open Council this 19th day of June, 2023.

**12.1.3 By-law 2023-96 (Vendors Prohibited) Rotaryfest 414 - 415**

Correspondence from Rotary Club of Sault Ste. Marie is on the Agenda.

Mover Councillor S. Spina

Seconder Councillor C. Gardi

Resolved that By-law 2023-96 being a by-law to prohibit vendors from locating on or near the grounds of Rotaryfest 2023 be passed in open Council this 19th day of June, 2023.

**12.1.4 By-law 2023-97 (Appointment) Naomi Thibault, Deputy Fire Chief Fire Prevention 416 - 416**

A report from the Fire Chief is on the Agenda.

Mover Councillor S. Spina

Seconder Councillor C. Gardi

Resolved that By-law 2023-97 being a by-law to appoint Naomi Thibault as Deputy Fire Chief Fire Prevention, Public Education and Emergency Management be passed in open Council this 19th day of June, 2023.

**12.1.5 By-law 2023-98 (Appointments) Fire Prevention Officers 417 - 417**

A report from the Fire Chief is on the Agenda.

Mover Councillor S. Spina

Seconder Councillor C. Gardi

Resolved that By-law 2023-98 being a by-law to appoint Paul Antonello, Dave Kochanowski, Gary Schryer and Craig Genys as Fire Prevention Officers for the purpose of enforcing By-law 81-404 and By-law 2009-82 be passed in open Council this 19th day of June, 2023.

- 12.1.6 By-law 2023-99 (Engineering) Asset Management Plan Fee Addendum Authorization (AECOM Canada Ltd.)**
- A report from the Manager of Purchasing is on the Agenda.
- Mover Councillor S. Spina  
Secunder Councillor C. Gardi  
Resolved that By-law 2023-99 being a by-law to authorize the execution of the AECOM Canada Ltd. fee addendum for non-core municipal infrastructure assets be passed in open Council this 19th day of June, 2023.
- 12.1.7 By-law 2023-100 (Council Procedure)** 450 - 483
- Council Report was passed by Council resolution on May 29, 2023.
- Mover Councillor S. Spina  
Secunder Councillor C. Gardi  
Resolved that By-law 2023-100 being a by-law to regulate the proceedings of the Council of the City of Sault Ste. Marie be passed in open Council this 19th day of June, 2023.
- 12.1.8 By-law 2023-101 (Delegation) Tourism Development Fund Agreements** 484 - 489
- A report from the Director Tourism and Community Development is on the Agenda.
- Mover Councillor S. Spina  
Secunder Councillor C. Gardi  
Resolved that By-law 2023-101 being a by-law to approve the standard form Tourism Development Fund ("TDF") Agreement and delegate to the Chief Administrative Officer ("CAO") signing authority to execute same on behalf of the City when the monetary amount to be contributed by the City is \$30,000 or greater and up to the CAO's approval limit of \$125,000.00; and further delegate to the Chief Administrative Officer of Community Development and Enterprise Services signing authority to execute same on behalf of the City when the monetary amount to be contributed by the City is up to \$30,000; and further delegate to the Director of Tourism and Community Development signing authority to execute same on behalf of the City when the monetary amount is up to \$10,000; all of which delegated authority shall be effective after the applicable TDF Agreement has been reviewed and approved by the Legal Department be passed in open Council this 19th day of June, 2023.
- 12.1.9 By-law 2023-102 (Engineering) Pioneer Construction Inc. Resurfacing Carmen's Way (Contract 2023-8E)** 490 - 492
- A report from the Municipal Services and Design Engineer is on the Agenda.
- Mover Councillor S. Spina

Seconder Councillor C. Gardi

Resolved that By-law 2023-102 being a by-law to authorize the execution of the Contract between the City and Pioneer Construction Inc. for Carmen's Way resurfacing (Contract 2023-8E) be passed in open Council this 19th day of June, 2023.

- 12.1.10 By-law 2023-104 (Official Plan Amendment) 352/360 Northern Avenue East and 31 Old Garden River Road Cara Community Corporation (Geoff Meakin) 493 - 495**

A report from the Junior Planner is on the Agenda.

Mover Councillor S. Spina

Seconder Councillor C. Gardi

Resolved that By-law 2023-104 being a by-law to adopt Amendment No. 247 to the Official Plan for the City of Sault Ste. Marie (Cara Community Corporation-Geoff Meakin-352/360 Northern Avenue East and 31 Old Garden River Road be passed in open Council this 19th day of June, 2023.

- 12.1.11 By-law 2023-105 (Zoning) 352/360 Northern Avenue East and 31 Old Garden River Road Cara Community Corporation (Geoff Meakin) 496 - 498**

A report from the Junior Planner is on the Agenda.

Mover Councillor S. Spina

Seconder Councillor C. Gardi

Resolved that By-law 2023-105 being a by-law to amend Sault Ste. Marie Zoning By-laws 2005-150 and 2005-151 concerning lands located at 352/360 Northern Avenue East and 31 Old Garden River Road (Cara Community Corporation-Geoff Meakin) be passed in open Council this 19th day of June, 2023.

- 12.1.12 By-law 2023-106 (Agreement) 49th Field Regiment (Funding Museum Windows) 499 - 503**

A report from the Manager of Recreation & Culture is on the Agenda.

Mover Councillor S. Spina

Seconder Councillor C. Gardi

Resolved that By-law 2023-106 being a by-law to authorize the execution of the Agreement between the City and Sault Ste. Marie 49 (SSM) Field Regiment RCA Historical Society for funding for the Sault Ste. Marie Museum Capital Window Renovation Project be passed in open Council this 19th day of June, 2023.

- 12.1.13 By-law 2023-107 (Appointments) Building – Appointing Inspectors 504 - 505**

Mover Councillor S. Spina

Seconder Councillor C. Gardi

Resolved that By-law 2023-107 being a by-law to appoint Inspectors under the *Building Code Act, 1992* and Municipal Law Enforcement Officers under the *Police Services Act* be passed in open Council this 19th day of June, 2023.

**12.1.14 By-law 2023-108 (Property Standards) Amendment to By-law 2012-9 506 - 512**

A report from the Solicitor is on the Agenda.

Mover Councillor S. Spina

Secunder Councillor C. Gardi

Resolved that By-law 2023-108 being a by-law to amend By-law 2012-9 (the Property Standards By-law for The Corporation of the City of Sault Ste. Marie) be passed in open Council this 19th day of June, 2023.

**12.1.15 By-law 2023-109 (Yard Maintenance) 513 - 514**

A report from the Solicitor is on the Agenda.

Mover Councillor S. Spina

Secunder Councillor C. Gardi

Resolved that By-law 2023-109 being a by-law to amend By-law 2012-10 (Yard Maintenance By-law for The Corporation of the City of Sault Ste. Marie) be passed in open Council this 19th day of June, 2023.

**12.1.16 By-law 2023-110 (Vacant Building) 515 - 529**

A report from the Solicitor is on the Agenda.

Mover Councillor S. Spina

Secunder Councillor C. Gardi

Resolved that By-law 2023-110 being a by-law to enact the Vacant Building By-law for The Corporation of the City of Sault Ste. Marie be passed in open Council this 19th day of June, 2023.

**12.2 By-laws before Council for FIRST and SECOND reading which do not require more than a simple majority**

**12.3 By-laws before Council for THIRD reading which do not require more than a simple majority**

**13. Questions By, New Business From, or Addresses by Members of Council Concerning Matters Not Otherwise on the Agenda**

**14. Closed Session**

Mover Councillor S. Spina

Secunder Councillor M. Scott

Resolved that this Council move into closed session to discuss one item relating to a plan to be applied to negotiations and one item concerning a proposed acquisition of land;

Further Be It Resolved that should the said closed session be adjourned, the Council may reconvene in closed session to discuss the same matters without the need for a further authorizing resolution.

*(Municipal Act section 239(2)(c) a proposed or pending acquisition or disposition of land by the municipality or local board; and (k) a position, plan, procedure, criteria or instruction to be applied to any negotiations carried on or to be carried on by or on behalf of the municipality or local board)*

**15. Adjournment**

Mover Councillor S. Spina

Seconder Councillor M. Scott

Resolved that this Council now adjourn.



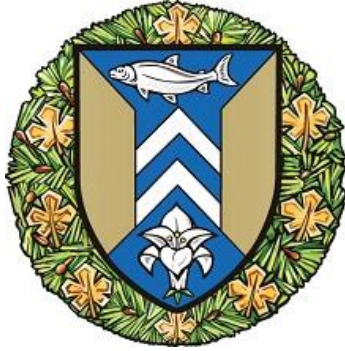

## REGULAR MEETING OF CITY COUNCIL MINUTES

Monday, May 29, 2023

4:30 pm

Council Chambers and Video Conference

Present: Mayor M. Shoemaker, Councillor S. Hollingsworth, Councillor S. Spina, Councillor L. Dufour, Councillor L. Vezeau-Allen, Councillor A. Caputo, Councillor R. Zagordo, Councillor M. Bruni, Councillor S. Kinach, Councillor C. Gardi, Councillor M. Scott (by zoom)

Officials: M. White, R. Tyczinski, L. Girardi, T. Vair, K. Fields, S. Schell, P. Johnson, N. Ottolino, S. Hamilton Beach, B. Lamming, T. Anderson, F. Coccimiglio, M. Zuppa, M. Borowicz-Sibenik, P. Tonazzo, C. Rumiell, S. Facey, R. Van Staveren, J. Rogers, E. Cormier, K. Marlow, I. Bruno, S. Lavergne

---

1. **Land Acknowledgement**

2. **Adoption of Minutes**

Moved by: Councillor M. Bruni

Seconded by: Councillor R. Zagordo

Resolved that the Minutes of the Regular Council Meeting of May 1, 2023 be approved.

**Carried**

**3. Questions and Information Arising Out of the Minutes and not Otherwise on the Agenda**

**4. Declaration of Pecuniary Interest**

**4.1 Mayor M. Shoemaker – Fifth Line East Property Acquisitions**

Law firm was involved with acquisitions.

**4.2 Councillor A. Caputo – Tiered Insurance for Temporary Patios**

Owner of a business with a temporary patio.

**5. Approve Agenda as Presented**

Moved by: Councillor S. Kinach

Seconded by: Councillor R. Zagordo

Resolved that the Agenda for May 29, 2023 City Council Meeting as presented be approved.

**Carried**

**6. Proclamations/Delegations**

**6.1 Queen Street Cruise**

**6.2 Spina Bifida and Hydrocephalus Canada**

Troy and Annette Chandler were in attendance.

**6.3 Bike to Work Week**

Andre Riopel, Sault Cycling Club and Bill Grawbarger, Algoma Public Health were in attendance.

**6.4 National AccessAbility Week**

D. Morrell, Accessibility Coordinator was in attendance.

**6.5 Environmental Sustainability Report**

E. Cormier, Sustainability Coordinator was in attendance.

**6.6 Community Efficiency Financing Feasibility Study**

Guru Kalyanraman, Enerva Energy Solutions Inc. was in attendance.

**7. Communications and Routine Reports of City Departments, Boards and Committees – Consent Agenda**

Moved by: Councillor S. Kinach

Seconded by: Councillor R. Zagordo

Resolved that all the items listed under date May 29, 2023 – Agenda item 7 – Consent Agenda save and except Agenda item 7.31 be approved as recommended.

**Carried**

**7.1 Correspondence**

Correspondence from CAO Malcolm White regarding his proposed retirement date was received by Council.

**7.2 2022 Municipal Election – Candidate Financial Filing Default**

The report of the City Clerk was received by Council.

Moved by: Councillor A. Caputo

Seconded by: Councillor R. Zagordo

Resolved that the report of the City Clerk concerning 2022 Municipal Election – Candidate Financial Filing Default be received as information.

**Carried**

**7.3 Cellular Service Extension**

The report of the Manager of Purchasing was received by Council.

Moved by: Councillor S. Kinach

Seconded by: Councillor A. Caputo

Resolved that the report of the Manager of Purchasing dated May 29, 2023 concerning Cellular Service – Extension be received and that Bell Mobility Inc. be approved to provide the services as required by various departments of the City of Sault Ste. Marie to the revised expiry of January 31, 2024.

**Carried**

**7.4 Public Works Equipment Purchase**

The report of the Manager of Purchasing was received by Council.

Moved by: Councillor S. Kinach

Seconded by: Councillor R. Zagordo

Resolved that the report of the Manager of Purchasing dated May 29, 2023 concerning revised equipment purchases as required by Public Works be received and that the purchase from Commercial Truck Equipment Corp. at the quoted amount of \$954,004 plus HST be approved.

**Carried**

**7.5 Digital Bid Posting Solution**

The report of the Manager of Purchasing was received by Council.

Moved by: Councillor M. Bruni

Seconded by: Councillor A. Caputo

Resolved that the report of the Manager of Purchasing dated May 29, 2023 concerning Budget Request for Digital Bid Posting Solution be received and that the project be approved with funding from 2023 Capital IT Reserve on initial purchase and through IT operating accounts for approved ongoing annual services.

**Carried**

**7.6 Northern Community Centre – Twin Pad Electric Ice Resurfacers**

The report of the Manager of Purchasing was received by Council.

Moved by: Councillor M. Bruni

Seconded by: Councillor R. Zagordo

Resolved that the report of the Manager of Purchasing dated May 29, 2023 concerning supply and delivery of one (1) electric ice resurfacers (Zamboni) as required by Arenas Division – CDES be received and that the purchase from Zamboni Canada Ltd., at the quoted amount of \$166,220 plus HST be approved;

Further that the reallocation of funds from available Project Contingency to Furniture, Fixture and Equipment Funding to cover the acquisition be approved.

**Carried**

**7.7 First Quarter Financial Report March 31, 2023**

The report of the Manager of Finance was received by Council.

Moved by: Councillor M. Bruni

Seconded by: Councillor R. Zagordo

That the report of the Manager of Finance dated May 29, 2023 concerning First Quarter Financial Report to March 31, 2023 be received as information.

**Carried**

**7.8 Year End Financial Report December 31, 2022**

The report of the Chief Financial Officer and Treasurer and Manager of Finance was received by Council.

Moved by: Councillor S. Kinach  
Seconded by: Councillor R. Zagordo

Resolved that the report of the Chief Financial Officer and Treasurer and Manager of Finance concerning 2022 year-end financial report be received and that the 2022 year-end reserve transfers be approved.

**Carried**

**7.9 Amendment to Next Generation 911 Agreement**

The report of the Manager of Information Technology was received by Council.

The relevant By-law 2023-92 is listed under item 12 of the Minutes.

**7.10 Ratification of Memorandum of Settlement – CUPE Local 3 (Community Services Group)**

The report of the Labour Relations Coordinator was received by Council.

Moved by: Councillor M. Bruni  
Seconded by: Councillor R. Zagordo

Resolved that the report of the Labour Relations Coordinator dated May 29, 2023 concerning Memorandum of Settlement for CUPE 3 Community Services Group be received and that Council ratify the Memorandum of Settlement.

**Carried**

**7.11 2023 Arts and Culture Assistance Program – Late Intake**

The report of the Manager of Recreation and Culture was received by Council.

Moved by: Councillor S. Kinach  
Seconded by: Councillor A. Caputo

Resolved that the report of the Manager of Recreation and Culture dated May 29, 2023 concerning the 2023 Arts and Culture Assistance Program Grants – Late Intake be received and that the following grants be approved:

1. Metis Nation of Ontario – Powley Case 29th Anniversary Commemoration: \$11,885
2. Friends of Ermatinger Clergue National Historic Site – Fall Rendezvous and Harvest Festival: \$6,229
3. Centre de Francophone – Festival du Jour de Franco-Ontariens Day Festival: \$2,869
4. Andree-Ann Deschenes – Commission Project: \$1,712
5. Rebeka Heron – Beka & Neko short film: \$1,494

6. Dustin Goodall – Pointless: \$1,642
7. Lucinda Hatt – Metis/Voyageur Art Creation Metis Heritage Centre SSM: \$1,665
8. Nicole Dyble – 2023 Concert Series: \$1,552
9. Sault Symphony Orchestra – Nutcracker Suite: \$5,150
10. Sault Blues Society: \$1,516
11. Sault Theatre Workshop: \$4,654
12. Brandon Ruch – Album Project: \$1,362
13. Over The Rainbow: \$2552
14. Northern Ontario Latin Hispanic Association – Gala Latina: \$2,787

**Carried**

#### **7.12 Buchan House Relocation**

The report of the Manager of Recreation and Culture was received by Council.

Moved by: Councillor S. Kinach

Seconded by: Councillor A. Caputo

Resolved that the report of the Manager of Recreation and Culture dated May 29, 2023 concerning the Buchan House Relocation and Addition be received and that the recommendation of the Municipal Heritage Committee regarding relocation of the Buchan House from Sault Ste. Marie Region Conservation Authority property to 943 Landslide Road pending approvals from the Sault Ste. Marie Region Conservation Authority and the City of Sault Ste. Marie be approved;

Further that the design as presented that has the front façade of the Buchan House facing Landslide Road and the materials used for the addition include board and batten siding and metal roofing be approved;

Further that the property owner continue to work with the Municipal Heritage Committee as the project progresses to ensure the materials selected for the addition are as outlined.

**Carried**

#### **7.13 Designated Property Grant – Buchan House**

The report of the Manager of Recreation and Culture was received by Council.

Moved by: Councillor M. Bruni

Seconded by: Councillor A. Caputo

Resolved that the report of the Manager of Recreation and Culture dated May 29, 2023 concerning Designated Heritage Property Grant – Buchan House be received and that a grant in the amount of \$3,000 to support the replacement of timbers and repairs to Buchan House be approved.

**Carried**

**7.14 CNIB Transit Accessibility Pilot Update**

The report of the Director of Community Services was received by Council

Moved by: Councillor S. Kinach

Seconded by: Councillor R. Zagordo

Resolved that the report of the Director of Community Services dated May 29, 2023 concerning the CNIB Transit Accessibility Pilot Update be received as information.

**Carried**

**7.15 Downtown Parking Passes**

The report of the Director of Community Services was received by Council.

Moved by: Councillor M. Bruni

Seconded by: Councillor A. Caputo

Resolved that the report of the Director, Community Services dated May 29, 2023 concerning Downtown Parking Passes with Limited Time be received and that a pilot to provide short term parking passes to Queen Street retailers not be pursued.

**Carried**

**7.16 Farebox Amending Agreement**

The report of the Director of Community Services was received by Council.

The relevant By-law 2023-76 is listed under item 12 of the Minutes.

**7.17 Noise By-Law Exemption for Summer Events**

The report of the Manager of Recreation and Culture has been received by Council.

The relevant By-law 2023-88 is listed under item 12 of the Minutes.

**7.18 Sound System Upgrades – GFL Memorial Gardens**

The report of the Director of Community Services was received by Council.

Moved by: Councillor M. Bruni

Seconded by: Councillor A. Caputo

Resolved that the report of the Director of Community Services dated May 29, 2023 concerning Sound System Upgrades at the GFL Memorial Gardens be received and that Council approve the cancellation of \$14,289 plus applicable HST in approved funding towards McMeeken Centre repairs, as approved in the 2021 Capital Budget in the amount of \$77,000, and reallocate to complete sound system upgrades at the GFL Memorial Gardens.

**Carried**

#### **7.19 NOHFC Industrial Park Loan Agreement**

The report of the Deputy CAO, Community Development and Enterprise Services was received by Council.

Moved by: Councillor S. Kinach

Seconded by: Councillor A. Caputo

Resolved that the report of the Deputy CAO, Community Development and Enterprise Services dated May 29, 2023 concerning the NOHFC Industrial Park Loan be received and that Council approve the use of the Industrial Park Reserve Fund balance of \$339,218 and internal debt in the amount of \$160,782 to provide the Industrial Park Loan settlement to NOHFC;

Further that Council approve the servicing of the internal debt from industrial land net sales subsequent to December 31, 2022;

Further that Council approve the future transfer of industrial property sales to the Industrial Park Reserve.

The relevant By-law 2023-86 is listed under item 12 of the Minutes.

**Carried**

#### **7.20 Northern Community Centre Agreement with Greater North Soccer Association**

The report of the Manager of Recreation and Culture was received by Council.

The relevant By-law 2023-91 is listed under item 12 of the Minutes.

#### **7.21 Strathclair Fieldhouse Agreement**

The report of the Manager of Recreation and Culture was received by Council.

The relevant By-law 2023-90 is listed under item 12 of the Minutes.

#### **7.22 316 Elizabeth Street Agreement**

The report of the Manager of Recreation and Culture was received by Council.

The relevant By-law 2023-89 is listed under item 12 of the Minutes.



**7.23 Stardust Pictures Studio Inc. EGCIIP Application**

The report of the Film, TV and Digital Media Coordinator was received by Council.

Moved by: Councillor M. Bruni

Seconded by: Councillor A. Caputo

Resolved that the report of the Film, TV and Digital Media Coordinator dated May 29, 2023 concerning Stardust Pictures Studios Inc.'s Economic Growth Community Improvement Plan application be received and that the recommendation of the EGCIIP Committee to allocate \$100,000 be approved.

**Carried**

**7.24 2023 Ditching Program**

The report of the Director of Public Works was received by Council.

Moved by: Councillor M. Bruni

Seconded by: Councillor A. Caputo

Resolved that the report of the Director of Public Works dated May 29, 2023 concerning Public Works 2023 Ditching Program be received as information.

**Carried**

**7.25 2023 Resurfacing Program**

The report of the Director of Engineering was received by Council.

Moved by: Councillor M. Bruni

Seconded by: Councillor R. Zagordo

Resolved that the report of the Director of Engineering dated May 29, 2023 concerning 2023 Road Resurfacing Program be approved.

**Carried**

**7.26 Fruit Tree Planting Pilot Project**

The report of the Director of Public Works was received by Council.

Moved by: Councillor S. Kinach

Seconded by: Councillor A. Caputo

Resolved that the report of the Director of Public Works dated May 29, 2023 concerning planting fruit trees be received and that Council support the planting of fruit trees in various neighborhood parks in the 2023 tree planting program as a pilot project.

**Carried**

**7.27 Trash to Treasure Event 2023**

The report of the Director of Public Works was received by Council.

Moved by: Councillor S. Kinach

Seconded by: Councillor A. Caputo

Resolved that the report of the Director of Public Works concerning Trash to Treasure Day 2023 be received as information.

**Carried**

**7.28 Landfill Operations and Monitoring 2022**

The report of the Manager of Development and Environmental Engineering was received by Council.

Moved by: Councillor M. Bruni

Seconded by: Councillor A. Caputo

Resolved that the report of the Manager of Development and Environmental Engineering dated May 29, 2023 concerning annual operations and monitoring reports for the municipal landfill be received as information.

**Carried**

**7.29 Road Closure – Metzger Street and McAllen Street**

The report of the Supervisor of Construction was received by Council.

The relevant By-law 2023-87 is listed under item 12 of the minutes.

**7.30 Winter Maintenance of Part of Maki Road**

The report of the Director of Public Works was received by Council.

The relevant By-law 2023-84 is listed under item 12 of the minutes.

**7.32 Request to Purchase Part of Barton Street and Part Lot 169 Hamilton Subdivision**

The report of the Solicitor was received by Council.

The relevant By-laws 2023-81, 2023-82 and 2023-83 are listed under item 12 of the minutes.

**7.33 Part Wiber Street Assumption Closing and Conveyance**

The report of the Assistant City Solicitor/Senior Litigation Counsel was received by Council.

The relevant By-laws 2023-77 and 2023-78 are listed under item 12 of the Minutes.

**7.34 Property Acquisition Part of 2467 Base Line**

The report of the Assistant City Solicitor/Senior Litigation Counsel was received by Council.  
 The relevant By-law 2023-79 is listed under item 12 of the Minutes.

**7.35 Sale of 724 Bonney Street to Habitat for Humanity**

The report of the Assistant City Solicitor/Senior Litigation Counsel was received by Council.  
 The relevant By-law 2023-93 is listed under item 12 of the Minutes.

**7.31 Fifth Line East Property Acquisitions**

Mayor M. Shoemaker declared a conflict on this item. (Law firm was involved with acquisitions.)

The report of the City Solicitor was received by Council.

Moved by: Councillor S. Kinach

Seconded by: Councillor R. Zagordo

Resolved that the report of the City Solicitor dated May 29, 2023 concerning the acquisition of three pieces of property located at 302, 310 and 334 Fifth Line East be received as information.

	<b>For</b>	<b>Against</b>	<b>Conflict</b>	<b>Absent</b>
Mayor M. Shoemaker			<b>X</b>	
Councillor S. Hollingsworth	X			
Councillor S. Spina	X			
Councillor L. Dufour	X			
Councillor L. Vezeau-Allen	X			
Councillor A. Caputo	X			
Councillor R. Zagordo	X			
Councillor M. Bruni	X			
Councillor S. Kinach	X			
Councillor C. Gardi	X			
Councillor M. Scott	X			
<b>Results</b>	<b>10</b>	<b>0</b>	<b>1</b>	<b>0</b>
				<b>Carried</b>

**8. Reports of City Departments, Boards and Committees**

**8.1 Administration**

**8.2 Corporate Services**

**8.2.1 Procedure By-Law Review**

The report of the City Clerk was received by Council.

Moved by: Councillor M. Bruni

Seconded by: Councillor R. Zagordo

Resolved that the report of the City Clerk dated May 29, 2023 concerning Procedure By-law Review 2023 be received and that the proposed amendments be incorporated into a new Procedure By-law.

	<b>For</b>	<b>Against</b>	<b>Conflict</b>	<b>Absent</b>
Mayor M. Shoemaker	X			
Councillor S. Hollingsworth	X			
Councillor S. Spina	X			
Councillor L. Dufour	X			
Councillor L. Vezeau-Allen	X			
Councillor A. Caputo	X			
Councillor R. Zagordo	X			
Councillor M. Bruni	X			
Councillor S. Kinach	X			
Councillor C. Gardi	X			
Councillor M. Scott	X			
<b>Results</b>	<b>11</b>	<b>0</b>	<b>0</b>	<b>0</b>
				<b>Carried</b>

**8.3 Community Development and Enterprise Services**

**8.3.1 Environmental Sustainability Report**

The report of the Sustainability Coordinator was received by Council.

Moved by: Councillor S. Kinach  
 Seconded by: Councillor R. Zagordo

Resolved that the report of the Sustainability Coordinator dated May 29, 2023 concerning 2021 – 2022 Sustainability Report be received as information.

	<b>For</b>	<b>Against</b>	<b>Conflict</b>	<b>Absent</b>
Mayor M. Shoemaker	X			
Councillor S. Hollingsworth	X			
Councillor S. Spina	X			
Councillor L. Dufour	X			
Councillor L. Vezeau-Allen	X			
Councillor A. Caputo	X			
Councillor R. Zagordo	X			
Councillor M. Bruni	X			
Councillor S. Kinach	X			
Councillor C. Gardi	X			
Councillor M. Scott	X			
<b>Results</b>	<b>11</b>	<b>0</b>	<b>0</b>	<b>0</b>
				<b>Carried</b>

**8.3.2 Community Efficiency Financing Program Design Study**

The report of the Sustainability Coordinator was received by Council.

Moved by: Councillor M. Bruni  
 Seconded by: Councillor A. Caputo

Resolved that the report of the Sustainability Coordinator dated May 29, 2023 concerning Community Efficiency Financing Program Design Study be received and that staff be authorized to proceed with an application to the Federation of Canadian Municipalities Green Municipal Fund program for funding for a Program Design Study.

	<b>For</b>	<b>Against</b>	<b>Conflict</b>	<b>Absent</b>
Mayor M. Shoemaker	X			
Councillor S. Hollingsworth	X			

Councillor S. Spina	X			
Councillor L. Dufour	X			
Councillor L. Vezeau-Allen	X			
Councillor A. Caputo	X			
Councillor R. Zagordo	X			
Councillor M. Bruni	X			
Councillor S. Kinach	X			
Councillor C. Gardi	X			
Councillor M. Scott	X			
<b>Results</b>	<b>11</b>	<b>0</b>	<b>0</b>	<b>0</b>
				<b>Carried</b>

**8.4 Public Works and Engineering Services**

**8.5 Fire Services**

**8.6 Legal**

**8.6.1 Tiered Insurance for Temporary Patios**

Councillor A. Caputo declared a conflict on this item. (Owner of a business with a temporary patio.)

The report of the City Solicitor was received by Council.

Moved by: Councillor L. Dufour

Seconded by: Councillor M. Bruni

Resolved that the report of the City Solicitor dated May 29, 2023 concerning a tiered approach to temporary patio coverage be received and that liability insurance in the amount of \$5 million be required for temporary patios serving alcohol and patios abutting a street (whether or not alcohol is served) and that liability insurance of \$2 million be required for temporary patios which do not serve alcohol.

An amendment to By-law 2023-71 will appear on a future Council Agenda

	<b>For</b>	<b>Against</b>	<b>Conflict</b>	<b>Absent</b>
Mayor M. Shoemaker		X		
Councillor S. Hollingsworth		X		

May 29, 2023 Council Minutes

Councillor S. Spina		X		
Councillor L. Dufour	X			
Councillor L. Vezeau-Allen		X		
Councillor A. Caputo			X	
Councillor R. Zagordo		X		
Councillor M. Bruni	X			
Councillor S. Kinach		X		
Councillor C. Gardi		X		
Councillor M. Scott		X		
<b>Results</b>	<b>2</b>	<b>8</b>	<b>1</b>	<b>0</b>
				<b>Defeated</b>

Moved by: Councillor C. Gardi  
 Seconded by: Councillor S. Spina

Resolved that the report of the City Solicitor dated May 29, 2023 concerning a tiered approach to temporary patio coverage be received and that \$5 million in liability insurance be required for all temporary patios.

	<b>For</b>	<b>Against</b>	<b>Conflict</b>	<b>Absent</b>
Mayor M. Shoemaker		X		
Councillor S. Hollingsworth		X		
Councillor S. Spina	X			
Councillor L. Dufour	X			
Councillor L. Vezeau-Allen		X		
Councillor A. Caputo			X	
Councillor R. Zagordo	X			
Councillor M. Bruni		X		
Councillor S. Kinach		X		
Councillor C. Gardi	X			
Councillor M. Scott		X		

**Results** **4** **6** **1** **0**  
**Defeated**

Moved by: Councillor S. Spina  
 Seconded by: Councillor S. Kinach

Resolved that the report of the City Solicitor dated May 29, 2023 concerning a tiered approach to temporary patio coverage be received as information.

	<b>For</b>	<b>Against</b>	<b>Conflict</b>	<b>Absent</b>
Mayor M. Shoemaker	X			
Councillor S. Hollingsworth	X			
Councillor S. Spina	X			
Councillor L. Dufour	X			
Councillor L. Vezeau-Allen	X			
Councillor A. Caputo			<b>X</b>	
Councillor R. Zagordo	X			
Councillor M. Bruni	X			
Councillor S. Kinach	X			
Councillor C. Gardi		X		
Councillor M. Scott	X			
<b>Results</b>	<b>9</b>	<b>1</b>	<b>1</b>	<b>0</b>
				<b>Carried</b>

**8.7 Planning**

**8.8 Boards and Committees**

**9. Unfinished Business, Notice of Motions and Resolutions Placed on Agenda by Members of Council**

**9.1 Food Truck Park Proposal**

Moved by: Councillor A. Caputo  
 Seconded by: Councillor R. Zagordo

Whereas a great deal of interest around food trucks has been expressed by citizens and entrepreneurs alike; and



Whereas having a designated area for the operation of food trucks would make obtaining a permit and doing business in Sault Ste Marie more attractive to operators; and

Whereas food trucks would bring a new facet to the already vibrant and diverse food scene in Sault Ste Marie; and

Whereas a food truck park would create: more jobs, additional revenue for The City, further opportunities for entrepreneurs in our city and more opportunity for citizens to enjoy and patronize our downtown:

Now Therefore Be It Resolved that staff be requested to report on the feasibility of the construction of a covered structure within the downtown area to house a bar and seating area which would be the hub of the Food Truck Park, as well as determine an equitable application process for food truck operators to be able to participate in this venture.

	<b>For</b>	<b>Against</b>	<b>Conflict</b>	<b>Absent</b>
Mayor M. Shoemaker	X			
Councillor S. Hollingsworth	X			
Councillor S. Spina	X			
Councillor L. Dufour	X			
Councillor L. Vezeau-Allen	X			
Councillor A. Caputo	X			
Councillor R. Zagordo	X			
Councillor M. Bruni	X			
Councillor S. Kinach	X			
Councillor C. Gardi	X			
Councillor M. Scott	X			
<b>Results</b>	<b>11</b>	<b>0</b>	<b>0</b>	<b>0</b>
				<b>Carried</b>

**9.2 Living Wage**

Moved by: Councillor A. Caputo  
 Seconded by: Councillor L. Vezeau-Allen

Whereas a living wage is defined as the minimum income necessary for a worker to meet their basic needs; and

Whereas the Sault Ste. Marie Poverty Round Table published the Progress On Impact Report in January of 2020 and an action item was to encourage employers to pay a living wage to all employees; and

Whereas the living wage for Sault Ste Marie according to Ontario Living Wage Network is currently set at \$19.70/hour; and

Whereas part-time and student jobs recently posted within the Corporation of the City of Sault Ste Marie are being compensated at a rate of \$15.61/hour or less; and

Whereas a living wage could help bring more jobseekers forward to these very important, front line positions within the Corporation; and

Whereas quality of life is one of our strategic pillars;

Now Therefore Be It Resolved that staff be requested to report back to Council regarding instituting a living wage policy for the Corporation of the City of Sault Ste. Marie.

	<b>For</b>	<b>Against</b>	<b>Conflict</b>	<b>Absent</b>
Mayor M. Shoemaker	X			
Councillor S. Hollingsworth	X			
Councillor S. Spina	X			
Councillor L. Dufour	X			
Councillor L. Vezeau-Allen	X			
Councillor A. Caputo	X			
Councillor R. Zagordo	X			
Councillor M. Bruni	X			
Councillor S. Kinach		X		
Councillor C. Gardi	X			
Councillor M. Scott	X			
<b>Results</b>	<b>10</b>	<b>1</b>	<b>0</b>	<b>0</b>

**Carried**

### 9.3 Bail Review

Moved by: Councillor S. Hollingsworth

Seconded by: Councillor S. Spina

Whereas the cost of policing and emergency services in northern communities is harming a community’s ability to support local social and health issues; and

Whereas a small percentage of those affected by an addiction in the communities of Northern Ontario are committing crimes; and

Whereas many of those committing crimes are not housed in the correctional system, therefore, remain in our communities, often those that do require treatment for their addiction issue receive none; and

Whereas some committing crimes become violent, but are released back into the community, due to the negative impacts of federal Bill C-75; and

Whereas the Federation of Northern Ontario Municipalities (FONOM) believes that more must be done by the federal government on bail reform;

Now Therefore Be It Resolved that the Council of the City of Sault Ste. Marie requests the federal government make these legislative changes:

- Create a designation of a chronic persistent offender;
- Allow community impact statements at bail and at bail hearings;
- Create reverse onus in bail for all firearms offences;
- All bail-related gun charges go to the Superior Court for bail release;

Further Be It Resolved that a copy of this resolution be sent to the Prime Minister, Federal Justice Minister, the Premier of Ontario, the Attorney General, the Solicitor General, Minister of Infrastructure, Minister of Municipal Affairs, Northeastern MPs and MPPs, Leaders of the Opposition, the Association of Municipalities of Ontario, and the Federation of Northern Ontario Municipalities.

	<b>For</b>	<b>Against</b>	<b>Conflict</b>	<b>Absent</b>
Mayor M. Shoemaker	X			
Councillor S. Hollingsworth	X			
Councillor S. Spina	X			
Councillor L. Dufour	X			
Councillor L. Vezeau-Allen	X			
Councillor A. Caputo	X			
Councillor R. Zagordo	X			

Councillor M. Bruni	X			
Councillor S. Kinach	X			
Councillor C. Gardi	X			
Councillor M. Scott	X			
<b>Results</b>	<b>11</b>	<b>0</b>	<b>0</b>	<b>0</b>
				<b>Carried</b>

**9.4 Cell Service – Highway 17 North**

*Withdrawn at the request of mover and seconder.*

Moved by: Councillor S. Hollingsworth

Seconded by: Councillor S. Spina

Whereas along the Trans-Canada Highway between the municipalities of Sault Ste. Marie and Wawa are no signal pits; and

Whereas the “dead spots” are conspicuous by their absence; and

Whereas there are numerous economic benefits to having dependable cell coverage, but most importantly for safety of our constituents that travel for work, pleasure and family; and

Whereas those that have been at an accident scene have had to drive miles and miles to find cell coverage to call for police, an ambulance and/or for general help, sometimes leaving an accident victim alone; and

Whereas reliable cell coverage for the north is a lifeline that can result in life or death; and

Whereas the Federation of Northern Ontario Municipalities (FONOM) continues to lobby the provincial and federal governments to invest into reliable cell coverage for the north and we as a city should support their efforts; and

Whereas Sault Ste. Marie is the largest municipality that should take on the responsibility to work with surrounding communities to lobby the provincial and federal governments for reliable cell coverage along the Trans-Canada Highway to Wawa;

Now Therefore Be It Resolved that a cell coverage committee be established to work closely with surrounding communities situated on highway 17 north to Wawa to establish a petition, a formal request that will be delivered to Premier Doug Ford, Minister of Innovation, Science and Industry of Canada Francois-Philippe Champagne, MP Terry Sheehan, and MPP Ross Romano by fall 2023 asking for immediate action to ensure safety of those traveling along this portion of the Trans-Canada highway.

**9.5 Arena Air Quality**

Moved by: Councillor S. Kinach

Seconded by: Councillor C. Gardi

Whereas indoor air quality is one of the main factors in long term health effects; and

Whereas indoor air quality deals with a wide range of pollutants such as asbestos, carbon monoxide, lead, nitrogen dioxide, radon, particulate matter, etc.; and

Whereas with the introduction of the electric Zamboni we now have a major difference between arenas; and

Whereas the difference in air quality in arenas with electric and non-electric Zambonis should be compared; and

Whereas it is the City’s goal to provide healthy indoor air quality in its arenas;

Now Therefore Be It Resolved that staff be requested to report on the cost to implement an air quality study at all City arenas for next season and provide a recommendation as to whether to undertake such a study.

	<b>For</b>	<b>Against</b>	<b>Conflict</b>	<b>Absent</b>
Mayor M. Shoemaker	X			
Councillor S. Hollingsworth	X			
Councillor S. Spina	X			
Councillor L. Dufour	X			
Councillor L. Vezeau-Allen	X			
Councillor A. Caputo	X			
Councillor R. Zagordo	X			
Councillor M. Bruni	X			
Councillor S. Kinach	X			
Councillor C. Gardi	X			
Councillor M. Scott	X			
<b>Results</b>	<b>11</b>	<b>0</b>	<b>0</b>	<b>0</b>
				<b>Carried</b>

**10. Committee of the Whole for the Purpose of Such Matters as are Referred to it by the Council by Resolution**

**11. Adoption of Report of the Committee of the Whole**

**12. Consideration and Passing of By-laws**

Moved by: Councillor M. Bruni

Seconded by: Councillor R. Zagordo

Resolved that all By-laws under item 12 of the Agenda under date May 29, 2023 be approved.

**Carried**

**12.1 By-laws before Council to be passed which do not require more than a simple majority**

**12.1.1 By-law 2023-76 (Agreement) CUBIC Transit Farebox Amendment**

Moved by: Councillor S. Kinach

Seconded by: Councillor R. Zagordo

Resolved that By-law 2023-76 being a by-law to authorize the execution of the Amending Agreement between the City and Cubic Transportation Services, Inc. for the Transit farebox technology payment processing services be passed in open Council this 29th day of May, 2023.

**Carried**

**12.1.2 By-law 2023-77 (Street Assumption) 72 Corey Avenue formerly known as part of Wiber Street**

Moved by: Councillor S. Kinach

Seconded by: Councillor R. Zagordo

Resolved that By-law 2023-77 being a by-law to assume for public use and establish as a public street, formerly known as part of Wiber Street, now known as 72 Corey Avenue, being PIN 31504-0364, be passed in open Council this 29th day of May, 2023.

**Carried**

**12.1.3 By-law 2023-79 (Property Acquisition) Part of 2467 Base Line (1372055 Ontario Limited Scott McWilliam)**

Moved by: Councillor S. Kinach

Seconded by: Councillor R. Zagordo

Resolved that By-law 2023-79 being a by-law to authorize the acquisition of part of 2467 Base Line (1372055 Ontario Limited – Scott McWilliam) be passed in open Council this 29th day of May, 2023.

**Carried**

**12.1.4 By-law 2023-80 (Street Assumptions) Various**

Moved by: Councillor S. Kinach

Seconded by: Councillor R. Zagordo

Resolved that By-law 2023-80 being a by-law to assume for public use and establish as public streets various parcels of land conveyed to the City be passed in open Council this 29th day of May, 2023.

**Carried**

**12.1.5 By-law 2023-81 (Street Assumption) Part of Barton Street**

Moved by: Councillor S. Kinach

Seconded by: Councillor R. Zagordo

Resolved that By-law 2023-81 being a by-law to assume for public use and establish as a public street that portion of Barton Street described as PART OF PIN 31613-0163 (LT) PART BARTON ST PL 58 AWENGE; SAULT STE. MARIE be passed in open Council this 29th day of May, 2023.

**Carried**

**12.1.6 By-law 2023-83 (Property Sale) Frank Marrello Abutting 68 Victoria Street**

Moved by: Councillor S. Kinach

Seconded by: Councillor R. Zagordo

Resolved that By-law 2023-83 being a by-law to declare the City owned property legally described as PART OF PIN 31613-0145 (LT) PART LOT 169 PL 58 AWENGE; SAULT STE. MARIE being property abutting 68 Victoria Street as surplus to the City's needs and to authorize the disposition of the said property to Frank Marrello or as otherwise directed be passed in open Council this 29th day of May, 2023.

**Carried**

**12.1.7 By-law 2023-84 (Agreement) Brookfield Power Wind Prince LP Winter Maintenance Maki Road north of Allard Lake**

Moved by: Councillor S. Kinach

Seconded by: Councillor R. Zagordo

Resolved that By-law 2023-84 being a by-law to authorize the execution of the Agreement between the City and Brookfield Power Wind Prince LP to provide winter maintenance for a portion of Maki Road north of Allard Lake be passed in open Council this 29th day of May, 2023.

**Carried**

**12.1.8 By-law 2023-85 (Agreement) Diamond Head Sprinklers Inc. for West End Splash Pad**

Moved by: Councillor S. Kinach

Seconded by: Councillor R. Zagordo

Resolved that By-law 2023-85 being a by-law to authorize the execution of the Agreement between the City and Diamond Head Sprinklers Inc. for the West End Splash Pad be passed in open Council this 29th day of May, 2023.

**Carried**

**12.1.9 By-law 2023-86 (Agreement) NOHFC (Northern Ontario Heritage Fund Corporation) Industrial Park Loan**

Moved by: Councillor S. Kinach

Seconded by: Councillor R. Zagordo

Resolved that By-law 2023-86 being a by-law to authorize the execution of the Agreement between the City and Northern Ontario Heritage Fund Corporation for the Industrial Park Loan settlement agreement be passed in open Council this 29th day of May, 2023.

**Carried**

**12.1.10 By-law 2023-87 (Temporary Street Closing) Metzger Street and McAllen Street at Central Street (Central Street Aqueduct Repairs)**

Moved by: Councillor S. Kinach

Seconded by: Councillor R. Zagordo

Resolved that By-law 2023-87 being a by-law to permit the temporary closing of Metzger Street and McAllen Street at Central Street for six (6) weeks from May 30, 2023 to July 11, 2023 to facilitate outstanding work for Contract 2022-9E Central Street Aqueduct Repairs by EllisDon Industrial Inc. be passed in open Council this 29th day of May, 2023.

**Carried**

**12.1.11 By-law 2023-88 (Regulations) Noise By-law Exemption 2023 Summer Events**

Moved by: Councillor S. Kinach

Seconded by: Councillor R. Zagordo

Resolved that By-law 2023-88 being a by-law to exempt the various locations of the 2023 Summer Events on July 13, 14, 15 and July 22, 2023 from the Noise Control By-law 80-200 be passed in open Council this 29th day of May, 2023.

**Carried**



**12.1.12 By-law 2023-89 (Agreement) Greater North Soccer Association Lease 316 Elizabeth Street**

Moved by: Councillor S. Kinach

Seconded by: Councillor R. Zagordo

Resolved that By-law 2023-89 being a by-law to authorize the execution of the Assignment Agreement between the City and Greater North Soccer Association for the lease of a portion of the former fire hall building located at 316 Elizabeth Street be passed by Council this 29th day of May, 2023.

**Carried**

**12.1.13 By-law 2023-90 (Agreement) Greater North Soccer Association Strathclair Sports Complex**

Moved by: Councillor S. Kinach

Seconded by: Councillor R. Zagordo

Resolved that By-law 2023-90 being a by-law to authorize the execution of the Assignment Agreement between the City and Greater North Soccer Association for the use of soccer fields and related matters at the Strathclair Sports Complex be passed in open Council this 29th day of May, 2023.

**Carried**

**12.1.14 By-law 2023-91 (Agreement) Greater North Soccer Association Northern Community Centre**

Moved by: Councillor S. Kinach

Seconded by: Councillor R. Zagordo

Resolved that By-law 2023-91 being a by-law to authorize the execution of the Assignment Agreement between the City and Greater North Soccer Association for the use of indoor soccer fields and related matters at the Northern Community Centre be passed in open Council this 29th day of May, 2023.

**Carried**

**12.1.15 By-law 2023-92 (Agreement) Amending Netagen NG911 Commander 911**

Moved by: Councillor S. Kinach

Seconded by: Councillor R. Zagordo

Resolved that Bylaw 2023-92 being a by-law to authorize the execution of Amendment Agreement 1 between the City and Netagen Communication Technologies Inc. (Netagen) to

amend the Master Services Agreement dated May 31, 2022 for the use of Netagen Commander 911 services be passed in open Council this 29th day of May, 2023.

**Carried**

**12.1.16 By-law 2023-93 (Property Sale) 724 Bonney Street – Habitat for Humanity**

Moved by: Councillor S. Kinach  
Seconded by: Councillor R. Zagordo

Resolved that By-law 2023-93 being a by-law to authorize the sale of surplus property being 724 Bonney Street, legally described as PIN 31592-0236 (LT) LT 11-13 BLK 11 PL 1751 KORAH; PT LANE BLK 11 PL 1751 KORAH CLOSED BY T220708 PT 2 & 3 1R4853 to Habitat for Humanity be passed in open Council this 29th day of May, 2023.

**Carried**

**12.2 By-laws before Council for FIRST and SECOND reading which do not require more than a simple majority**

**12.2.1 By-law 2023-78 (Street Closing and Conveyance) Part of Wiber Street (now known as 72 Corey Avenue)**

Moved by: Councillor S. Kinach  
Seconded by: Councillor R. Zagordo

Resolved that By-law 2023-78 being a by-law to stop up, close and authorize the conveyance of a portion of Wiber Street now known as 72 Corey Avenue, being PIN 31504-0364(LT) be read a FIRST and SECOND time and passed in open Council this 29th day of May, 2023.

**Carried**

**12.2.2 By-law 2023-82 (Street Closing and Conveyance) Part of Barton Street**

Moved by: Councillor S. Kinach  
Seconded by: Councillor R. Zagordo

Resolved that By-law 2023-82 being a by-law to stop up, close and authorize the conveyance of a portion of Barton Street described as PART OF PIN 31613-0163 (LT) PART BARTON ST PL 58 AWENGE; SAULT STE. MARIE be read a FIRST and SECOND time and passed in open Council this 29th day of May, 2023.

**Carried**

**12.3 By-laws before Council for THIRD reading which do not require more than a simple majority**

**12.3.1 By-law 2023-32 (Street Closing and Conveyance) Herbert Street**

Moved by: Councillor S. Kinach

Seconded by: Councillor R. Zagordo

Resolved that By-law 2023-32 being a by-law to stop up, close and authorize the conveyance of a portion of Herbert Street, Dixon Subdivision, Plan 52431, PART PIN 31535-0225 (LT) PART HERBERT ST PL 2012 ST. MARY'S; PART HERBERT ST PL H496 ST. MARY'S; BEING PARTS 1, 2, 3, 4 AND 5 PLAN 1R13987; SUBJECT TO T91957, T91958, T91959, T91960, T91961, be read a THIRD time in open Council and passed this 29th day of May, 2023.

**Carried**

**13. Questions By, New Business From, or Addresses by Members of Council Concerning Matters Not Otherwise on the Agenda**

**14. Closed Session**

Moved by: Councillor M. Bruni

Seconded by: Councillor A. Caputo

Resolved that this Council move into closed session as a continuation of the May 1, 2023 closed session and to consider:

- one item concerning a proposed disposition of land;
- one item concerning litigation; and
- one item concerning application of a plan to be applied to negotiations

Further Be It Resolved that should the said closed session be adjourned, the Council may reconvene in closed session to discuss the same matters without the need for a further authorizing resolution.

*(Municipal Act section 239(2)(c) a proposed or pending acquisition or disposition of land by the municipality or local board; (e) litigation or potential litigation, including matters before administrative tribunals, affecting the municipality or local board; and (k) a position, plan, procedure, criteria or instruction to be applied to any negotiations carried on or to be carried on by or on behalf of the municipality or local board)*

**Carried**

**15. Adjournment**

Moved by: Councillor M. Bruni

Seconded by: Councillor A. Caputo

Resolved that this Council now adjourn.

**Carried**

---

Mayor

---

City Clerk

OFFICE OF THE MAYOR



CORPORATION OF THE  
CITY OF SAULT STE. MARIE

June 8, 2023

The Honourable Sean Fraser  
Minister of Immigration, Refugees and Citizenship  
House of Commons  
Ottawa, Ontario  
K1A 0A6

Dear Minister Fraser:

**RE: Rural and Northern Immigration Pilot Program**

On behalf of the Corporation of the City of Sault Ste. Marie, I am writing to express my strong support of the Government of Canada's Rural and Northern Immigration Pilot Program (RNIP), and to call for it to become permanent.

Sault Ste. Marie has a significant need for increased immigration to address demographic, age structure and youth outmigration challenges – as demonstrated by the City's success with RNIP since it was launched. In November 2019, Sault Ste. Marie was the first of the 11 RNIP cities to accept applications. In 2022, the City of Sault Ste. Marie exceeded its goal of 125 allocated recommendations, issuing 213 recommendation letters to applicants who then applied to Immigration, Refugees and Citizenship Canada for permanent residency. These candidates successfully secured full-time, permanent positions with 137 local businesses and organizations. Top positions included roles in supervisory or managerial positions, followed by senior roles performing executive functions.

Included with this package are letters of support from Sault Ste. Marie-based companies who have benefitted from RNIP and who, like the City of Sault Ste. Marie, want to see the program made permanent. These employers represent roughly one quarter of our active workforce.

Sault Ste. Marie's labour force history is one that is largely built on historic immigration influxes. For Sault Ste. Marie to continue to thrive as a community, we need a renewed labour force, which we cannot build organically. As the attachments to this letter demonstrate, our community recognizes that increased immigration is needed and can be accommodated.

Simply put, Sault Ste. Marie has the opportunity, along with the social and the institutional infrastructure necessary to support increased immigration through RNIP, and I urge the Government of Canada to make the program permanent.

Sincerely,

**MATTHEW M. SHOEMAKER**  
Mayor, Sault Ste. Marie

April 18, 2023

The Honourable Sean Fraser  
Minister of Immigration, Refugees and Citizenship of Canada  
House of Commons  
Ottawa, Ontario,  
Canada  
K1A 0A6

Dear Minister Fraser,

On behalf of Algoma Steel Inc., I am writing this letter to indicate our support for making the Rural and Northern Immigration Pilot Program (RNIP) a permanent program.

Our organization has been able to use the pilot program successfully and we would be eager to utilize the program in the future. Having access to international talent is critical for the ongoing success and growth of our community. With our Electric Arc Furnace transformation in progress, the demand for skilled trade workers is on the rise and the RNIP program can assist us to bridge this gap.

According to a 2020 report from the Federal Ministry of Immigration, Refugees and Citizenship Canada, 26% of everyone in the Sault Ste. Marie workforce was over the age of 55. Overall, nearly 11,000 people are likely to retire in the next decade or so, as they are 55 and older. At 47 years, our median age is higher than provincial average (41), the oldest of the large city centres in northern Ontario. The Demographic Dependency Ratio (DDR) indicates there will be 1.5 times as many people leaving the workforce then there are people available to enter it in the coming years.

The RNIP program has placed Sault Ste. Marie on the map for many newcomers interested in coming to Canada. Rather than just consider the typical Toronto-Montreal-Vancouver options, the program has helped highlight our community and all the professional opportunities available. Further, it allows our community to showcase the incredible quality of life, affordable housing and amenities that Sault Ste. Marie has to offer.

The RNIP program offers support to our workplace attraction efforts and we urge the Federal government to make this program a permanent program. Our smaller, rural and northern communities can utilize this program to help us compete for global talent.

Thank you for reviewing this letter and we look forward to hearing positive news about the RNIP program in the future

Sincerely,



Laura Devoni, Director - Corporate Affairs & Sustainability

Cc:

Mayor Matthew Shoemaker, City of Sault Ste. Marie  
Tom Vair, Deputy CAO, CDES, City of Sault Ste. Marie

March 28, 2023

The Honourable Sean Fraser  
Minister of Immigration, Refugees and Citizenship of Canada  
House of Commons  
Ottawa, Ontario,  
Canada  
K1A 0A6

Dear Minister Fraser,

On behalf of Algoma Tubes Inc., I am writing this letter to indicate our strong support for making the Rural and Northern Immigration Pilot Program (RNIP) a permanent program.

Our organization has been able to utilize the pilot program to great success and having access to international talent is critical to the ongoing success and growth of our community.

According to a 2020 report from the Federal Ministry of Immigration, Refugees and Citizenship Canada, 26% of everyone in the Sault Ste. Marie workforce was over the age of 55. Overall, nearly 11,000 people are likely to retire in the next decade or so, as they are 55 and older. At 47 years, our median age is higher than provincial average (41), the oldest of the large city centres in northern Ontario. The Demographic Dependency Ratio (DDR) indicates there will be 1.5 times as many people leaving the workforce then there are people available to enter it in the coming years.

The RNIP program has placed Sault Ste. Marie on the map for many newcomers interested in coming to Canada. Rather than just consider the typical Toronto-Montreal-Vancouver options, the program has helped highlight our community and all the professional opportunities available. Further, it allows our community to showcase the incredible quality of life, affordable housing and amenities that Sault Ste. Marie has to offer.

The RNIP program has become a critical component of our workforce attraction efforts and we urge the Federal government to make this program a permanent program. Our smaller, rural and northern communities need this unique program in order to compete for global talent.

Thank you for reviewing this letter and we look forward to hearing positive news about the RNIP program in the future.

Sincerely,



HR Sr. Director – Tenaris Canada

Cc:

Mayor Matthew Shoemaker, City of Sault Ste. Marie  
Tom Vair, Deputy CAO, CDES, City of Sault Ste. Marie



The Honourable Sean Fraser  
Minister of Immigration, Refugees and Citizenship of Canada  
House of Commons  
Ottawa, Ontario,  
Canada  
K1A 0A6

Dear Minister Fraser,

On behalf of Sault Area Hospital, I am writing this letter to indicate our strong support for making the Rural and Northern Immigration Pilot Program (RNIP) a permanent program.

Our organization has been able to utilize the pilot program to great success and having access to international talent is critical to the ongoing success and growth of our community.

To date we have filled out 6 RNIP applications, with 25 more to go as we have offered various Full Time Registered Nurse positions.

According to a 2020 report from the Federal Ministry of Immigration, Refugees and Citizenship Canada, 26% of everyone in the Sault Ste. Marie workforce was over the age of 55. Overall, nearly 11,000 people are likely to retire in the next decade or so, as they are 55 and older. At 47 years, our median age is higher than provincial average (41), the oldest of the large city centres in northern Ontario. The Demographic Dependency Ratio (DDR) indicates there will be 1.5 times as many people leaving the workforce then there are people available to enter it in the coming years.

The RNIP program has placed Sault Ste. Marie on the map for many newcomers interested in coming to Canada. Rather than just consider the typical Toronto-Montreal-Vancouver options, the program has helped highlight our community and all the professional opportunities available. Further, it allows our community to showcase the incredible quality of life, affordable housing and amenities that Sault Ste. Marie has to offer.

The RNIP program has become a critical component of our workforce attraction efforts and we urge the Federal government to make this program a permanent program. Our smaller, rural and northern communities need this unique program in order to compete for global talent.

Thank you for reviewing this letter and we look forward to hearing positive news about the RNIP program in the future.

Sincerely,

Rosanna Naslovar  
Manager Recruitment and Retention

Cc:  
Mayor Matthew Shoemaker, City of Sault Ste. Marie  
Tom Vair, Deputy CAO, CDES, City of Sault S



March 31, 2023

The Honourable Sean Fraser  
Minister of Immigration, Refugees and Citizenship of Canada  
House of Commons  
Ottawa, Ontario,  
Canada  
K1A 0A6

Dear Minister Fraser,

On behalf of TULLOCH, I am writing this letter to indicate our strong support for making the Rural and Northern Immigration Pilot Program (RNIP) a permanent program.

Our organization has been able to utilize the pilot program to great success and having access to international talent is critical to the ongoing success and growth of our community. Through this program TULLOCH employed two individuals in Sault Ste Marie, two in Sudbury and one in Thunder Bay. Finding skilled individuals has been a challenge in our Northern communities and we are so grateful for this program.

According to a 2020 report from the Federal Ministry of Immigration, Refugees and Citizenship Canada, 26% of everyone in the Sault Ste. Marie workforce was over the age of 55. Overall, nearly 11,000 people are likely to retire in the next decade or so, as they are 55 and older. At 47 years, our median age is higher than provincial average (41), the oldest of the large city centres in northern Ontario. The Demographic Dependency Ratio (DDR) indicates there will be 1.5 times as many people leaving the workforce then there are people available to enter it in the coming years.

The RNIP program has placed Sault Ste. Marie on the map for many newcomers interested in coming to Canada. Rather than just consider the typical Toronto-Montreal-Vancouver options, the program has helped highlight our community and all the professional opportunities available. Further, it allows our community to showcase the incredible quality of life, affordable housing and amenities that Sault Ste. Marie has to offer.

The RNIP program has become a critical component of our workforce attraction efforts and we urge the Federal government to make this program a permanent program. Our smaller, rural and northern communities need this unique program in order to compete for global talent.

Thank you for reviewing this letter and we look forward to hearing positive news about the RNIP program in the future.

Sincerely,



Jen Sjaarda, CHRP  
People and Culture Manager  
TULLOCH

Cc:

Mayor Matthew Shoemaker, City of Sault Ste. Marie  
Tom Vair, Deputy CAO, CDES, City of Sault Ste. Marie

March 31, 2023

The Honourable Sean Fraser  
Minister of Immigration, Refugees and Citizenship of Canada  
House of Commons  
Ottawa, Ontario, Canada, K1A 0A6

Dear Minister Fraser,

On behalf of N1 Solutions I am writing this letter to indicate our strong support for making the Rural and Northern Immigration Pilot Program (RNIP) a permanent program.

Our organization has been able to utilize the pilot program to great success and having access to international talent is critical to the ongoing success and growth of our community.

According to a 2020 report from the Federal Ministry of Immigration, Refugees and Citizenship Canada, 26% of everyone in the Sault Ste. Marie workforce was over the age of 55. Overall, nearly 11,000 people are likely to retire in the next decade or so, as they are 55 and older. At 47 years, our median age is higher than provincial average (41), the oldest of the large city centres in northern Ontario. The Demographic Dependency Ratio (DDR) indicates there will be 1.5 times as many people leaving the workforce then there are people available to enter it in the coming years.

The RNIP program has placed Sault Ste. Marie on the map for many newcomers interested in coming to Canada. Rather than just consider the typical Toronto-Montreal-Vancouver options, the program has helped highlight our community and all the professional opportunities available. Further, it allows our community to showcase the incredible quality of life, affordable housing and amenities that Sault Ste. Marie has to offer.

The RNIP program has become a critical component of our workforce attraction efforts and we urge the Federal government to make this program a permanent program. Our smaller, rural and northern communities need this unique program in order to compete for global talent.

Thank you for reviewing this letter and we look forward to hearing positive news about the RNIP program in the future.

Sincerely,  
**N1 Solutions**

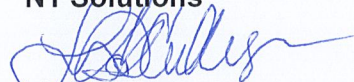

Lisa Culligan  
Manager of Talent and Culture

Cc:  
Mayor Matthew Shoemaker, City of Sault Ste. Marie  
Tom Vair, Deputy CAO, CDES, City of Sault Ste. Marie

March 30, 2023

The Honourable Sean Fraser  
Minister of Immigration, Refugees and Citizenship of Canada  
House of Commons  
Ottawa, Ontario,  
Canada  
K1A 0A6

Dear Minister Fraser,

On behalf of the FJ Davey Home, I am writing this letter to indicate our strong support for making the Rural and Northern Immigration Pilot Program (RNIP) a permanent program.

Our organization has been able to utilize the pilot program to great success and having access to international talent is critical to the ongoing success and growth of our community.

According to a 2020 report from the Federal Ministry of Immigration, Refugees and Citizenship Canada, 26% of everyone in the Sault Ste. Marie workforce was over the age of 55. Overall, nearly 11,000 people are likely to retire in the next decade or so, as they are 55 and older. At 47 years, our median age is higher than provincial average (41), the oldest of the large city centres in northern Ontario. The Demographic Dependency Ratio (DDR) indicates there will be 1.5 times as many people leaving the workforce then there are people available to enter it in the coming years.

The RNIP program has placed Sault Ste. Marie on the map for many newcomers interested in coming to Canada. Rather than just consider the typical Toronto-Montreal-Vancouver options, the program has helped highlight our community and all the professional opportunities available. Further, it allows our community to showcase the incredible quality of life, affordable housing and amenities that Sault Ste. Marie has to offer.

The RNIP program has become a critical component of our workforce attraction efforts and we urge the Federal government to make this program a permanent program. Our smaller, rural and northern communities need this unique program in order to compete for global talent.

Thank you for reviewing this letter and we look forward to hearing positive news about the RNIP program in the future.

Sincerely,



---

Connie Lee Executive Director / Administrator

Cc:

Mayor Matthew Shoemaker, City of Sault Ste. Marie



April 13, 2023

Northern Ontario Large Urban Mayors (NOLUM)

**RE: Letter of support - permanent implementation of Rural & Northern Immigration Pilot**

Dear Mayors:

I am writing you today on behalf of the Ontario's North Economic Development Corporation (ONEDC), an organization comprised of the five major centres in Northern Ontario's economic development offices. Our communities have realized significant benefits from the Rural and Northern Immigration Pilot program, and we are pleased to submit this letter as our formal expression of interest for the Rural and Northern Immigration Pilot (RNIP) to become a permanent program for Canada.

Research from the Northern Policy Institute and Statistics Canada continues to demonstrate population decline, aging demographics, and significant workforce shortage in Northern Ontario, all which have been exacerbated by the Covid-19 pandemic.

This pilot has proven to be very successful in helping our businesses fill key roles and address labour shortages, and these many new residents and their families have made our communities more vibrant and resilient. We have also benefitted from significant support from FedNor and recognize funding for the resources to deliver the program are crucial to successful results.

Establishing a permanent program for RNIP as an important pathway to permanent residency will help our cities continue to meet these challenges head-on as we continue to implement a community-based response to attraction, recruitment and retention.

Sincerely,

Christy Marinig  
Chairperson, ONEDC  
CEO, Timmins Economic Development Corporation  
705-360-2649



369 Queen Street East, Suite 1  
Sault Ste. Marie, ON, P6A 1Z4

**The Honourable Sean Fraser**

Minister of Immigration, Refugees and Citizenship of Canada  
House of Commons  
Ottawa, Ontario,  
Canada  
K1A 0A6

May 15, 2023

Dear Minister Fraser,

The Sault Ste. Marie Chamber of Commerce represents over 650 members that account for 16,000 jobs in our region, or, 48% of the labour force. The Rural and Northern Immigration Pilot (RNIP) is playing a key role in addressing the labour shortages and achieving the federal government's recently announced immigration targets, but it is set to expire in August 2024.

To date Sault Ste. Marie Rural and Northern Immigration Pilot (RNIP) has recommended 255 candidates with related dependents of 195 for a total of 450 new residents. There are many more in the queue and our community is confident the program will meet, and with high probability exceed, our allotment of 325 this year. Our employers and members are embracing this program and using it strategically to bring much needed talent to the community.

Not only is this a benefit to our businesses and stakeholders our immigrants and their family members expand our community's culture by introducing new ideas and customs, improve our economy through hard work and entrepreneurship, expands the tax base helping fund government activity and makes the world more connected.

As per Statistics Canada, in the second quarter of 2022, employers across all sectors in Canada were actively seeking to fill nearly one million (997,000) vacant positions, the highest quarterly number on record. Vacancies were up 4.7 percent (+45,000) from the first quarter, and 42.3 percent (+296,500) higher than in the second quarter of 2021. To address the labour shortage, in November 2022, the federal government announced a new immigration plan that would see Canada welcome 500,000 immigrants per year by 2025. RNIP is already playing its part in achieving these ambitious targets, but if the program is made permanent, it can contribute even more. As of June 30, 2022, Immigration, Refugees and Citizenship Canada reports that 1,130 newcomers have arrived in Canada under the RNIP. They have helped fill gaps in healthcare, manufacturing, transportation, retail, and hospitality.

RNIP was launched based on the success of the Atlantic Immigration Program (AIP). AIP was initially launched as a pilot program in 2017 and became permanent in 2021. A recent Statistics Canada study shows that high immigrant retention rates in Atlantic Canada can be credited to the success of AIP. Outcomes such as this are emerging from the pilots across Canada and Sault Ste. Marie is no exception.

The Sault Ste. Marie Chamber of Commerce fully endorses RNIP and encourages the government of Canada to work with participating communities of the Rural and Northern Immigration Pilot to make it a permanent program effective August 2024.



Rory Ring, CEO  
Sault Ste. Marie Chamber of Commerce



PLATO Testing  
231 Regent St.  
Fredericton, NB  
E3B 3W8

March 28, 2023

The Honourable Sean Fraser  
Minister of Immigration, Refugees and Citizenship of Canada  
House of Commons  
Ottawa, Ontario,  
Canada  
K1A 0A6

Dear Minister Fraser,

On behalf of PLATO Testing I am writing this letter to indicate our strong support for making the Rural and Northern Immigration Pilot Program (RNIP) a permanent program.

Our organization has been able to utilize the pilot program to great success and having access to international talent is critical to the ongoing success and growth of both our community and our company operations in SSM. We currently employ ten (10) full time employees who have been hired through the RNIP program within the last 12 months.

According to a 2020 report from the Federal Ministry of Immigration, Refugees and Citizenship Canada, 26% of everyone in the Sault Ste. Marie workforce was over the age of 55. Overall, nearly 11,000 people are likely to retire in the next decade or so, as they are 55 and older. At 47 years, our median age is higher than provincial average (41), the oldest of the large city centres in northern Ontario. The Demographic Dependency Ratio (DDR) indicates there will be 1.5 times as many people leaving the workforce then there are people available to enter it in the coming years.

The RNIP program has placed Sault Ste. Marie on the map for many newcomers interested in coming to Canada. Rather than just consider the typical Toronto-Montreal-Vancouver options, the program has helped highlight our community and all the professional opportunities available. Further, it allows our community to showcase the incredible quality of life, affordable housing and amenities that Sault Ste. Marie has to offer.

The RNIP program has become a critical component of our workforce attraction efforts and we urge the Federal government to make this program a permanent program. Our smaller, rural and northern communities need this unique program in order to compete for global talent.



PLATO Testing  
231 Regent St.  
Fredericton, NB  
E3B 3W8

Thank you for reviewing this letter and we look forward to hearing positive news about the RNIP program in the future.

Sincerely,

A handwritten signature in black ink, appearing to read "Scott Kennedy".

Scott Kennedy, CFO

Cc:

Mayor Matthew Shoemaker, City of Sault Ste. Marie

Tom Vair, Deputy CAO, CDES, City of Sault Ste. Marie



Date: March 28, 2023

The Honourable Sean Fraser  
Minister of Immigration, Refugees and Citizenship of Canada  
House of Commons  
Ottawa, Ontario,  
Canada  
K1A 0A6

Dear Minister Fraser,

On behalf of MicroAge Technical Services LTD., I am writing this letter to indicate our strong support for making the Rural and Northern Immigration Pilot Program (RNIP) a permanent program.

Our organization has been able to utilize the pilot program to great success and having access to international talent is critical to the ongoing success and growth of our community.

According to a 2020 report from the Federal Ministry of Immigration, Refugees and Citizenship Canada, 26% of everyone in the Sault Ste. Marie workforce was over the age of 55. Overall, nearly 11,000 people are likely to retire in the next decade or so, as they are 55 and older. At 47 years, our median age is higher than provincial average (41), the oldest of the large city centres in northern Ontario. The Demographic Dependency Ratio (DDR) indicates there will be 1.5 times as many people leaving the workforce then there are people available to enter it in the coming years.

The RNIP program has placed Sault Ste. Marie on the map for many newcomers interested in coming to Canada. Rather than just consider the typical Toronto-Montreal-Vancouver options, the program has helped highlight our community and all the professional opportunities available. Further, it allows our community to showcase the incredible quality of life, affordable housing and amenities that Sault Ste. Marie has to offer.

The RNIP program has become a critical component of our workforce attraction efforts and we urge the Federal government to make this program a permanent program. Our smaller, rural and northern communities need this unique program in order to compete for global talent.

Thank you for reviewing this letter and we look forward to hearing positive news about the RNIP program in the future.

Sincerely,

*Sam Foglia*

Sam Foglia

Cc:  
Mayor Matthew Shoemaker, City of Sault Ste. Marie  
Tom Vair, Deputy CAO, CDES, City of Sault Ste. Marie

March 28, 2023

The Honourable Sean Fraser  
Minister of Immigration, Refugees and Citizenship of Canada  
House of Commons  
Ottawa, Ontario,  
Canada  
K1A 0A6

Dear Minister Fraser,

On behalf of Chartwell Collegiate Heights Retirement Home, I am writing this letter to indicate our strong support for making the Rural and Northern Immigration Pilot Program (RNIP) a permanent program.

Our organization has been able to utilize the pilot program to great success and having access to international talent is critical to the ongoing success and growth of our community.

According to a 2020 report from the Federal Ministry of Immigration, Refugees and Citizenship Canada, 26% of everyone in the Sault Ste. Marie workforce was over the age of 55. Overall, nearly 11,000 people are likely to retire in the next decade or so, as they are 55 and older. At 47 years, our median age is higher than provincial average (41), the oldest of the large city centres in northern Ontario. The Demographic Dependency Ratio (DDR) indicates there will be 1.5 times as many people leaving the workforce then there are people available to enter it in the coming years.

The RNIP program has placed Sault Ste. Marie on the map for many newcomers interested in coming to Canada. Rather than just consider the typical Toronto-Montreal-Vancouver options, the program has helped highlight our community and all the professional opportunities available. Further, it allows our community to showcase the incredible quality of life, affordable housing and amenities that Sault Ste. Marie has to offer.

The RNIP program has become a critical component of our workforce attraction efforts and we urge the Federal government to make this program a permanent program. Our smaller, rural and northern communities need this unique program in order to compete for global talent.

Thank you for reviewing this letter and we look forward to hearing positive news about the RNIP program in the future.

Sincerely,

Annelise Wolfe  
General Manager  
[awolfe@chartwell.com](mailto:awolfe@chartwell.com)

Subject Line  
Page 2 of 2

Chartwell Collegiate Heights Retirement Home

Cc:  
Mayor Matthew Shoemaker, City of Sault Ste. Marie  
Tom Vair, Deputy CAO, CDES, City of Sault Ste. Marie

Date 14 April 2023

The Honourable Sean Fraser  
Minister of Immigration, Refugees and Citizenship of Canada  
House of Commons  
Ottawa, Ontario,  
Canada  
K1A 0A6

Dear Minister Fraser,

On behalf of Chuck's Roadhouse Bar and Grill, Sault Ste. Marie, I am writing this letter to indicate our strong support for making the Rural and Northern Immigration Pilot Program (RNIP) a permanent program.

Our organization has been able to utilize the pilot program to great success and having access to international talent is critical to the ongoing success and growth of our community.

According to a 2020 report from the Federal Ministry of Immigration, Refugees and Citizenship Canada, 26% of everyone in the Sault Ste. Marie workforce was over the age of 55. Overall, nearly 11,000 people are likely to retire in the next decade or so, as they are 55 and older. At 47 years, our median age is higher than provincial average (41), the oldest of the large city centres in northern Ontario. The Demographic Dependency Ratio (DDR) indicates there will be 1.5 times as many people leaving the workforce then there are people available to enter it in the coming years.

The RNIP program has placed Sault Ste. Marie on the map for many newcomers interested in coming to Canada. Rather than just consider the typical Toronto-Montreal-Vancouver options, the program has helped highlight our community and all the professional opportunities available. Further, it allows our community to showcase the incredible quality of life, affordable housing and amenities that Sault Ste. Marie has to offer.

The RNIP program has become a critical component of our workforce attraction efforts and we urge the Federal government to make this program a permanent program. Our smaller, rural and northern communities need this unique program in order to compete for global talent.

Thank you for reviewing this letter and we look forward to hearing positive news about the RNIP program in the future.

Sincerely,

Hardik Modi  
Franchisee  
+1(705)987-9839

Cc:  
Mayor Matthew Shoemaker, City of Sault Ste. Marie  
Tom Vair, Deputy CAO, CDES, City of Sault Ste. Marie



April 24, 2023

By email: [minister@cic.gc.ca](mailto:minister@cic.gc.ca)

Minister of Immigration, Refugees & Citizenship  
365 Laurier Avenue West  
Ottawa, ON  
K1A 1L1

**Re: Letter of support for the permanent implementation of the Rural and Northern Immigration Pilot**

Dear Honourable Sean Fraser,

On behalf of the Northern Ontario Large Urban Mayors (NOLUM), we are pleased to endorse the Ontario's North Economic Development Corporation (ONEDC)'s appeal for the Rural and Northern Immigration Pilot (RNIP) to become a permanent program in the region of northern Ontario.

Since its inception in 2020, the Rural and Northern Immigration Pilot has recommended over 300 newcomers to the region. These individuals have filled labour shortages, contributed to the local economy and created a more diverse and inclusive community.

Research from the Northern Policy Institute, Far Northeast Training Board and Statistics Canada continue to demonstrate population decline, aging demographics and significant workforce shortages in Northern Ontario, all which have been exacerbated by the Covid-19 pandemic.

Since the Pilot was implemented in our municipalities three years ago, it has proven to be very successful in filling key roles in our labour shortage. However, we are still facing these today, despite the success of the last three years. Immigration and newcomer attraction continue to be strategic priorities for our respective communities and we recognize the value of a diverse workforce.

Establishing a permanent Pilot program will help address these ongoing challenges as we continue to implement a community-based response to attraction, recruitment and retention. We encourage you to reach out to any one of us if you have any questions about the permanent implementation of this program in the cities of Greater Sudbury, North Bay, Sault Ste. Marie, Thunder Bay and Timmins, Ontario.

Sincerely,



Paul Lefebvre  
Mayor  
City of Greater Sudbury



Peter Chirico  
Mayor  
City of North Bay



Matthew Shoemaker  
Mayor  
City of Sault Ste Marie



Ken Boshcoff  
Mayor  
City of Thunder Bay



Michelle Boileau  
Mayor  
City of Timmins

CC: MP Viviane Lapointe – Sudbury  
The Honourable Anthony Rota – Nipissing  
MP Terry Sheehan – Sault Ste. Marie  
MP Charlie Angus – Timmins - James Bay  
The Honourable Patty Hajdu – Thunder Bay  
Mayor Paul Lefebvre  
Mayor Peter Chirico  
Mayor Matthew Shoemaker  
Mayor Ken Boshcoff  
Mayor Michelle Boileau  
RNIP Sudbury  
RNIP North Bay  
RNIP Sault Ste. Marie  
RNIP Timmins  
RNIP Thunder Bay

[viviane.lapointe@parl.gc.ca](mailto:viviane.lapointe@parl.gc.ca)  
[anthony.rota@parl.gc.ca](mailto:anthony.rota@parl.gc.ca)  
[terry.sheehan@parl.gc.ca](mailto:terry.sheehan@parl.gc.ca)  
[charlie.angus@parl.gc.ca](mailto:charlie.angus@parl.gc.ca)  
[patty.hajdu@parl.gc.ca](mailto:patty.hajdu@parl.gc.ca)  
[mayor@greatersudbury.ca](mailto:mayor@greatersudbury.ca)  
[mayorchirico@northbay.ca](mailto:mayorchirico@northbay.ca)  
[mayorsoffice@cityssm.on.ca](mailto:mayorsoffice@cityssm.on.ca)  
[ken.boshcoff@thunderbay.ca](mailto:ken.boshcoff@thunderbay.ca)  
[mayor@timmins.ca](mailto:mayor@timmins.ca)  
[movetosudbury@sudbury.ca](mailto:movetosudbury@sudbury.ca)  
[rnip@nbdcc.ca](mailto:rnip@nbdcc.ca)  
[labourforce@cityssm.on.ca](mailto:labourforce@cityssm.on.ca)  
[immigration@timmins.ca](mailto:immigration@timmins.ca)  
[develop@thunderbay.ca](mailto:develop@thunderbay.ca)

March 30, 2023

The Honourable Sean Fraser  
Minister of Immigration, Refugees and Citizenship of Canada  
House of Commons  
Ottawa, Ontario, Canada  
K1A 0A6

Dear Minister Fraser;

**Re; Rural and Northern Immigration Pilot Program (RNIP)**

Our company Soo Foundry & Machine is a medium size (70 plus employee) manufacturing company based, and with a long history, in Sault Ste. Marie, Ontario. The majority of our sales come from the Renewable Energy sector; Hydro and Wind. We also support the steel and mining sectors. We have done work across Canada and into the US market. Most of our workers are in the skilled trades.

Our growth, and simply maintaining existing manufacturing contracts we currently have, is limited by the availability of skilled workers. In a smaller City like Sault Ste. Marie, demographics are working against us. It is extremely difficult to get workers to leave the Greater Toronto Area, even for higher wages, which is no solution to Canada's skilled trade shortage. We do not see this changing. I believe many small communities across Canada have the same issue. Jobs in the trades are well paid positions, and stabilize communities. They create wealth and opportunities.

We have found far more success, as compared to the regional labour pool, with foreign workers. We have used the RNIP program with a number of employees with great success. We know this will continue. We work with Lackeisha Sogan, at the City of Sault Ste. Marie, who manages RNIP for our region. Lackeisha, helped us work through a complicated process to bring a Machinist from the Philippines to Sault Ste. Marie last October. She is also helped us with a Brazilian engineering technician, who is now a full-time employee at Soo Foundry, and

many others from different Countries. These individuals are fitting well into Sault Ste. Marie. We know will stay here with their families. None of this could have been done without Lackeisha and the RNIP program. RNIP puts small communities like Sault Ste. Marie on the international employment map.

We would strongly urge the Federal Government to make the RNIP program permanent. This important RNIP program is an investment in Canada. RNIP is a critical component of Soo Foundry & Machine's workforce attraction efforts.

We believe that if our Government wishes to create strong communities across Canada, and not just have almost all new immigrants, especially in skilled trades, go to major urban centers, then a permanent and ongoing RNIP program will support this effort.

Thank you for reviewing this letter. We look forward to hearing positive news about the RNIP program in the future. We would also be happy to provide more information about this important Canadian program;705 256 7456.

Sincerely,



Derek Hanchuk  
Management and New Business Inquiries



Robert Cohen  
President

Cc; Mayor Matthew Shoemaker, City of Sault Ste. Marie  
Tom Vair, Deputy CAO, CDES, City of Sault Ste. Marie



28 March, 2023

The Honourable Sean Fraser  
Minister of Immigration, Refugees and Citizenship of Canada  
House of Commons  
Ottawa, Ontario,  
Canada  
K1A 0A6

Dear Minister Fraser,

On behalf of JD Aero Technical Inc., I am writing this letter to indicate our strong support for making the Rural and Northern Immigration Pilot Program (RNIP) a permanent program.

Our organization has been able to utilize the pilot program to great success and having access to international talent is critical to sustaining our business and offering an opportunity for growth.

According to a 2018 report provided by the CCAA and Transport Canada, the Canadian Aviation sector was forecast to lose 5000 maintenance engineers by 2025. The COVID pandemic accelerated this shortage, the peak of which we are currently experiencing. Low enrollment in post-secondary programs and high competition for available graduates has created a critical skills gap. In short, there are no experienced engineers readily available and the only source we have been able to access is through international recruitment. The RNIP has given us an extremely effective means of accessing the safety and business critical personnel we need to keep the skies safe for Canadians and our international clients.

Canada's vastness and diversity is often bewildering to people considering immigration to this country, so they opt for the major centres of Toronto, Montreal, Vancouver and Calgary, which have high living costs and can be overwhelming to some, especially those who do not come from major centres. The RNIP has opened up the less internationally known regions of Canada to potential newcomers not wanting the hustle and bustle of metropolitan life, offering a fantastic alternative for quality of life.

As an organization, we are able to work with the RNIP quite easily, finding the process very straight-forward and allowing us to work hand-in-hand with our candidates and community partners to ensure a successful transition to life in Canada.

Thank you for reviewing this letter and we look forward to hearing positive news about the RNIP program in the future.

Sincerely,



Matt Socchia  
Director of Maintenance  
[msocchia@jdaeromaintenance.com](mailto:msocchia@jdaeromaintenance.com)  
705-779-3977 ext. 201

Cc:

Mayor Matthew Shoemaker, City of Sault Ste. Marie  
Tom Vair, Deputy CAO, CDES, City of Sault Ste. Marie



June 7, 2023.

The Honourable Sean Fraser  
Minister of Immigration, Refugees and Citizenship of Canada  
House of Commons  
Ottawa, Ontario,  
Canada  
K1A 0A6

Dear Minister Fraser,

On behalf of Delta Hotels by Marriott Sault Ste. Marie Waterfront, I am writing this letter to indicate our strong support for making the Rural and Northern Immigration Pilot Program (RNIP) a permanent program.

Our organization has been able to utilize the pilot program to great success and having access to international talent is critical to the ongoing success and growth of our community.

According to a 2020 report from the Federal Ministry of Immigration, Refugees and Citizenship Canada, 26% of everyone in the Sault Ste. Marie workforce was over the age of 55. Overall, nearly 11,000 people are likely to retire in the next decade or so, as they are 55 and older. At 47 years, our median age is higher than provincial average (41), the oldest of the large city centres in northern Ontario. The Demographic Dependency Ratio (DDR) indicates there will be 1.5 times as many people leaving the workforce then there are people available to enter it in the coming years.

The RNIP program has placed Sault Ste. Marie on the map for many newcomers interested in coming to Canada. Rather than just consider the typical Toronto-Montreal-Vancouver options, the program has helped highlight our community and all the professional opportunities available. Further, it allows our community to showcase the incredible quality of life, affordable housing and amenities that Sault Ste. Marie has to offer.

The RNIP program has become a critical component of our workforce attraction efforts and we urge the Federal government to make this program a permanent program. Our smaller, rural and northern communities need this unique program in order to compete for global talent.

Thank you for reviewing this letter and we look forward to hearing positive news about the RNIP program in the future.

Sincerely,

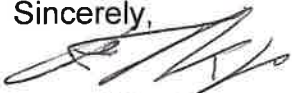

Kevin Wyer, General Manager Delta Hotels by Marriott Sault Ste. Marie Waterfront

Cc:  
Mayor Matthew Shoemaker, City of Sault Ste. Marie  
Tom Vair, Deputy CAO, CDES, City of Sault Ste. Marie

# Rotary

## Club of Sault Ste. Marie

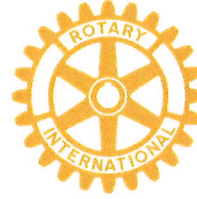

Mayor Shoemaker and Council  
The Corporation of the City of Sault Ste. Marie  
99 Foster Drive  
Sault Ste. Marie, ON  
P6A 5N1

May 23, 2023

Dear Mayor Shoemaker and Councilors:

The Rotary Club of Sault Ste. Marie would like to request the following pertaining to the operation of ROTARYFEST 2023 for July 13 - 15, 2023.

A) Use of

- 1) Clergue and Rowswell Parks for July 8-16,
- 2) The Civic Centre green space, corner of Bay and Foster Drives for July 8-July 16 for the midway,
- 3) the north 50' of the Civic Centre parking lot, on the north side of Russ Ramsay Way, from July 8-July 16
- 4) Closure of Ken Danby Way for July 8 – 16.

B) By-law

Control of what takes place on the festival grounds, adjacent sidewalks, and streets during the operation of the festival, especially pertaining to vendors. Anyone wishing to sell or demonstrate products on the grounds must first receive permission to do so from the ROTARYFEST committee. A fee may apply.

- 1) Russ Ramsay Way south of the entrance to the Senior Drop In Centre;
- 2) Foster Drive from Russ Ramsay Way to the east entrance to the south Civic Centre parking lot;
- 3) On the south side of Bay Street between Brock and East Streets, including the sidewalk;
- 4) Lower East Street south of Bay Street and Ken Danby Way;
- 5) The Senior Drop In Centre parking lot off of Foster Drive

On behalf of Rotary, I would like to thank you for your cooperation in this matter.

Sincerely,

A handwritten signature in black ink, appearing to read "Nilah Moss".

Nilah Moss  
Events Manager

cc: Virginia McLeod, Manager, Recreation and Culture

364 Queen St. East, Sault Ste. Marie, ON P6A 1Z1  
705-945-1279 ~ [www.rotarysault.com](http://www.rotarysault.com)

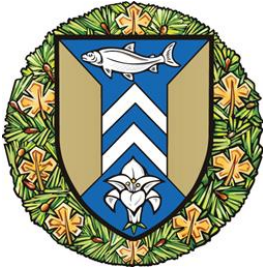

The Corporation of the  
City of Sault Ste. Marie  
**COUNCIL REPORT**

June 19, 2023

TO: Mayor Matthew Shoemaker and Members of City Council  
AUTHOR: Shelley J Schell, CPA, CA Chief Financial Officer &  
Treasurer  
DEPARTMENT: Corporate Services  
RE: 2024 Budget Schedule

---

**Purpose**

The purpose of this report is to provide Council the 2024 Budget Schedule.

**Background**

The Operating and Capital Budgets are strategic documents shaped by Council priorities and direct how the City uses its finances to deliver essential services. The budget schedule is provided to apprise Council of the 2024 timelines.

**Analysis**

Not applicable.

**Financial Implications**

There are no direct financial implications associated with the budget schedule.

**Strategic Plan / Policy Impact / Climate Impact**

This is an operational matter not articulated in the Strategic Plan.

**Recommendation**

It is therefore recommended that Council take the following action:

Resolved that the report of the Chief Financial Officer and Treasurer dated June 19, 2023 concerning the 2024 Budget Schedule be received as information.

Respectfully submitted,

Shelley J. Schell, CPA, CA  
Chief Financial Officer/Treasurer  
705.759.5355  
[s.schell@cityssm.on.ca](mailto:s.schell@cityssm.on.ca)

**THE CORPORATION OF THE CITY OF SAULT STE MARIE**  
**2024 BUDGET SCHEDULE**  
**OPERATING & CAPITAL BUDGET**

Completion Date

● Local / Levy Board Presentations including Outside Agency Reports

November 20, 2023

● Preliminary Budget to Council - Operating & Capital  
User Fees approval

November 20, 2023

● Budget deliberation

December 11 & 12, 2023

Post Budget Approval

● Tax Policy Analysis, Options and Tax Rates

April 2024, or earlier if available

● Capping Options  
(date is dependent upon release of Education Rates by Province)

April 2024, or earlier if available

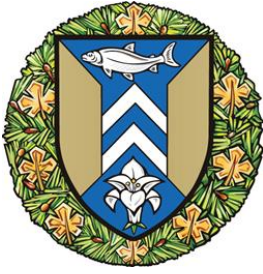

**The Corporation of the  
City of Sault Ste. Marie**

**C O U N C I L   R E P O R T**

June 19, 2023

TO: Mayor Matthew Shoemaker and Members of City Council  
AUTHOR: Karen Marlow, Manager of Purchasing  
DEPARTMENT: Corporate Services  
RE: RFP – Engagement of an Integrity Commissioner for the  
City of Sault Ste. Marie

---

**Purpose**

Staff is seeking approval of a proposal for Engagement of an Integrity Commissioner for the City of Sault Ste. Marie for a five-year term, as required by Clerks Department.

**Background**

The City's Code of Conduct for Council and Local Boards was adopted by By-law 2017-242 on December 11, 2017 and amended by By-law 2019-39 on February 11, 2019. The role of Integrity Commissioner is outlined within the Code of Conduct.

The Integrity Commissioner is responsible for performing in an independent manner the functions assigned by the municipality with respect to the application of the Code of Conduct for members of Council and local boards.

The Request for Proposal was publicly advertised and proposal document forwarded to all firms on the bidders list. Proposals were required to be submitted for consideration no later than 4 p.m. on May 4, 2023.

**Analysis**

Proposals from three (3) proponents were received prior to the closing date  
ADR Chambers Inc., Toronto, ON  
Ironside Consulting Services Inc., Prince Township, ON  
Sage Analytics Inc., Edmonton, AB

The proposals received have been evaluated by a committee comprised of staff from Clerks Administration and CAO Offices. It is the consensus of the Evaluation Committee that the proponent scoring the highest in the evaluation process is Ironside Consulting Services Inc. Ironside is the incumbent provider of the services and city staff are extremely satisfied with the experience and quality of services that has been maintained.

**Financial Implications**

Billings will vary subject to need, as service will be accessed only as required or desired. The cost of this service will be funded from the Clerks Department Operational Consultants Account. Sufficient funds will be budgeted annually for these charges.

**Strategic Plan / Policy Impact / Climate Impact**

This is an operational matter not articulated in the corporate Strategic Plan.

**Recommendation**

It is therefore recommended that Council take the following action:

The relevant By-law 2023-95 is listed under item 12 of the Agenda and will be read with all by-laws under that item.

Respectfully submitted,

Karen Marlow

Manager of Purchasing

705.759.5298

[k.marlow@cityssm.on.ca](mailto:k.marlow@cityssm.on.ca)

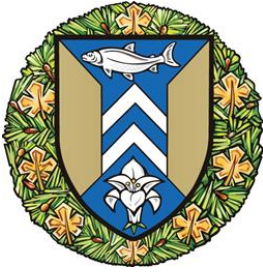

The Corporation of the  
City of Sault Ste. Marie

**C O U N C I L   R E P O R T**

June 19, 2023

TO: Mayor Matthew Shoemaker and Members of City Council  
AUTHOR: Karen Marlow, Manager of Purchasing  
DEPARTMENT: Corporate Services  
RE: Asset Management Plan Phase II Non-Core Assets

---

**Purpose**

Staff is seeking Council approval of an Asset Management Plan to comply with the second phase of regulatory requirements in respect to its non-core municipal infrastructure assets as per Ontario Regulation 588/17. The work would build out the Phase I plan to include all assets required by July 2024 as required by Public Works and Engineering Services.

**Background**

Ontario Regulation 588/17 has four key milestones related to the asset management planning process. The City's strategic asset management policy was finalized June 3, 2019, which addressed the first milestone.

In May 2021 a Request for Proposal was issued for the provision of professional services for development of the Asset Management Plan Phase I related to the City's core infrastructure and related ancillary asset management work. Core assets included in this program as defined by the Regulation include Wastewater Assets; Stormwater Management Assets; Roads; and Bridges and Culverts.

At the July 12, 2021 Council meeting the following resolution was passed.

Resolved that the report of the Manager of Purchasing dated July 12, 2021 concerning RFP Asset Management Planning – Consulting Engineering be received and that the proposal submitted by AECOM Canada Ltd. with fees of \$210,000 plus HST as outlined in their proposal submitted as required by Public Works and Engineering Services, be approved.

**Analysis**

The Manager of Development and Environmental Engineering requests that single source non-competitive approval be considered to utilize AECOM Canada Ltd. for Phase II of the asset management plan.

- AECOM was selected through proposal selection process for Phase I work scoring the highest in the evaluation process, successfully completing



Phase I of the asset management plan and staff is satisfied with the consultant's performance;

- The work outline is similar. Phase II builds upon Phase I to include non-core assets;
- AECOM is also completing legislated asset management work for PUC assets, wholly owned by the City, which also creates some synergies.

AECOM has prepared a work plan proposal for Phase II Non-Core Asset Management, which has been reviewed and accepted by City staff from Public Works and Engineering Services and Finance.

This single source request is in accordance with Purchasing By-law Non-Competitive item 22.3 h) in the best interests of City for continued services with AECOM Canada Ltd on Phase II of this program.

### **Financial Implications**

AECOM's proposed fee of \$214,700 will result in a total expenditure of \$218,479 including the non-rebatable portion of HST.

The 2023 approved Capital Budget included \$100,000 for Asset Management Plan – Phase II. The remaining \$118,479 will be funded from previous commitments within Miscellaneous Construction budget and amounts committed in 2023 for environmental assessments and studies.

### **Strategic Plan / Policy Impact / Climate Impact**

This Project is linked to the Strategic Plan focus area of Infrastructure, and specifically maintaining existing infrastructure.

### **Recommendation**

It is therefore recommended that Council take the following action:

The relevant By-law 2023-99 is listed under item 12 of the Agenda and will be read with all by-laws under that item.

Respectfully submitted,

Karen Marlow  
Manager of Purchasing  
705.759-5298  
[k.marlow@cityssm.on.ca](mailto:k.marlow@cityssm.on.ca)

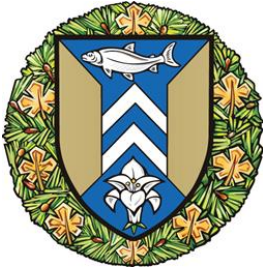

The Corporation of the  
City of Sault Ste. Marie  
**COUNCIL REPORT**

June 19, 2023

TO: Mayor Matthew Shoemaker and Members of City Council  
AUTHOR: Karen Marlow, Manager of Purchasing  
DEPARTMENT: Corporate Services  
RE: Refuse Truck Rental Extension – Public Works Waste  
Management

---

**Purpose**

Staff is seeking Council approval of extension for a current rental of a refuse truck as required by Public Works Waste Management Division.

**Background**

In December 2022, the Manager Equipment Public Works and Engineering requested that sole source non-competitive approval be considered for short term rental of refuse truck at landfill to replace equipment that in service for repairs. Big Truck Rental is only supplier to rent new or late model auto arm refuse truck/packer and over six-month term January to June, the total expense including shipping was quoted at \$73,600 (plus HST). This request was approved within staff financial values, in accordance with Purchasing By-law item 22.3 c) technical reasons as only supplier with rental of the specialized equipment required.

**Analysis**

The repaired units are still periodically troublesome and the rental truck has been the most reliable unit. Public Works has purchased two refuse trucks in 2023, that have a tentative delivery date of December 2023. It is expected that these units will be received at that time, but the manufacturer can not guarantee. An extension therefore of the current rental is required until these units are received as its replacement.

**Financial Implications**

The quoted pricing from Big Truck Rental for an extension until end of December 2023, is \$70,800 (plus HST).

Total expenditure including this extension request is \$146,942 including non-rebatable portion of HST.

Funding for refuse truck rental will be drawn from the Landfill operating budget.

Refuse Truck Rental Extension – Public Works Waste Management

June 19, 2023

Page 2.

**Strategic Plan / Policy Impact / Climate Impact**

This is an operational matter not articulated in the Corporate Strategic Plan.

**Recommendation**

It is therefore recommended that Council take the following action:

Resolved that the report of the Manager of Purchasing dated June 19, 2023 concerning rental of refuse truck as required by Public Works Waste Management Division be received and that extension of the rental from July to December 2023 for the additional amount of \$70,800 (plus HST) be approved.

Respectfully submitted,

Karen Marlow

Manager of Purchasing

705.759-5298

[k.marlow@cityssm.on.ca](mailto:k.marlow@cityssm.on.ca)

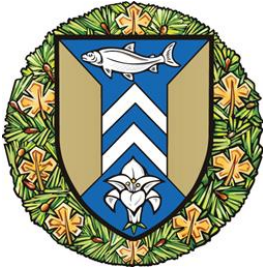

The Corporation of the  
City of Sault Ste. Marie  
**COUNCIL REPORT**

June 19, 2023

TO: Mayor Matthew Shoemaker and Members of City Council  
AUTHOR: Karen Marlow, Manager of Purchasing  
DEPARTMENT: Corporate Services  
RE: Tender for Firefighter Bunker Gear – Fire Services

---

**Purpose**

Staff is seeking Council approval of the tender for supply and delivery of firefighter bunker gear for a period of up to five years upon mutual agreement as required by Fire Services.

**Background**

The tender was publicly advertised and tender documents were forwarded to all firms on the bidders list. A public opening of the tenders took place on June 1, 2023 with the Deputy City Clerk in attendance.

**Analysis**

The tender received has been thoroughly evaluated and reviewed with the Fire Chief and Deputy Fire Chief and the low tendered price meeting specifications, has been identified on the attached summary.

**Financial Implications**

The tendered price for 80 sets of firefighter bunker gear is approximately \$301,128 including non-rebatable HST.

The 2023 approved Capital Budget for the purchase of bunker gear is \$300,000 (HST included). Fire Services has confirmed the shortfall can be accommodated from within Operational Funding – Fire Administration Project Expenditures.

Ongoing annual service requirements will be funded through the approved budgets from Fire Services operations account.

**Strategic Plan / Policy Impact / Climate Impact**

This is an operational matter not articulated in the Corporate Strategic Plan.

**Recommendation**

It is therefore recommended that Council take the following action:

Resolved that the report of the Manager of Purchasing dated June 19, 2023 concerning Firefighter Bunker Gear be received and that the tender of A.J. Stone Company Limited of \$295,920 (HST extra) be approved.

Tender for Firefighter Bunker Gear – Fire Services

June 19, 2023

Page 2.

Respectfully submitted,

Karen Marlow

Manager of Purchasing

705.759-5298

[k.marlow@cityssm.on.ca](mailto:k.marlow@cityssm.on.ca)

FINANCE DEPARTMENT  
PURCHASING DIVISION  
BUDGET: \$300,000 (Approved 2023)

Received: June 1, 2023  
File: 2023-FIR-01-T

SUMMARY OF TENDERS  
FIREFIGHTER BUNKER GEAR

<u>Firm</u>	<u>Qty.</u>	<u>Unit Price</u>	<u>Total Tendered Price</u> <u>(HST extra)</u>	<u>Delivery</u>	<u>Remarks</u>
A. J. Stone Company Limited Vaughan, ON	80	\$3,699.00	\$295,920.00	16 weeks	Meets Specifications

Note: The low tendered price, meeting specifications, is boxed above.

Although only one tender was received, it is deemed fair and equitable.

A.J. Stone Company Limited is the incumbent provider of the Bunker Gear, and SSMFS is extremely satisfied with the quality of product and service that has been maintained.

The total cost to the City will be \$301,128 including the non-rebatable portion of the HST.

It is my recommendation that the tendered price, submitted by A. J. Stone Company Limited, be accepted.

Karen Marlow  
Manager of Purchasing

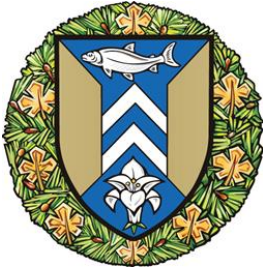

The Corporation of the  
City of Sault Ste. Marie  
**COUNCIL REPORT**

June 19, 2023

TO: Mayor Matthew Shoemaker and Members of City Council  
AUTHOR: Lisa Petrocco, CPA, CGA – Manager of Taxation  
DEPARTMENT: Corporate Services  
RE: Property Tax Appeals – June 2023

---

**Purpose**

Staff is requesting that Council approve several tax refunds, as well as deny one application, pursuant to section 357 of the *Municipal Act*.

**Background**

A listing of applications received for adjustment of realty taxes pursuant to section 357 of the *Municipal Act* is attached to this report.

**Analysis**

Staff had the Municipal Property Assessment Corporation review the applications to recommend the amount of the assessment that Council could consider adjusting.

Regarding the application that staff is recommending be denied, the applicant was requested on multiple occasions to submit additional documentation to support the application. The applicant has not submitted appropriate or sufficient documentation to allow the merits of the application to be evaluated.

**Financial Implications**

There is an annual budget allocation for tax write-offs. The tax refunds of \$41,108.55 being recommended by staff can be accommodated within the existing budget allocation.

**Strategic Plan / Policy Impact / Climate Impact**

Not applicable.

**Recommendation**

It is therefore recommended that Council take the following action:

Resolved that the report of the Manager of Taxation dated June 19, 2023 concerning Property Tax Appeals be received and that the recommended amendments to tax records pursuant to section 357 of the *Municipal Act* be approved, including the denial of one application.

Property Tax Appeals

June 19, 2023

Page 2.

Respectfully submitted,

Lisa Petrocco, CPA, CGA

Manager of Taxation

705.541.7065

[l.petrocco@cityssm.on.ca](mailto:l.petrocco@cityssm.on.ca)



APPLICATION TO COUNCIL TO CANCEL  
OR REFUND PROPERTY TAXES PURSUANT TO SECTION 357  
OF THE MUNICIPAL ACT, 2001

THE CORPORATION OF THE CITY OF SAULT STE. MARIE  
PROPERTY TAX APPEALS

DATE: 2023 06 19  
PAGE: 1 of 1

ROLL #	PROPERTY ADDRESS	PERSON ASSESSED	TAX CLASS	REASON	APPEAL NO.	TAXES	INTEREST	TOTAL
<b>2022</b>								
020-045-027-00	00911 QUEEN ST E	2836295 ONTARIO INC	CT>RT	A	22-040	(2,238.31)	(63.05)	(2,301.36)
030-075-041-00	00760 SECOND LINE E	ARK DEVELOPMENTS INC	XT	D(i)	22-041	(662.68)	-	(662.68)
040-030-040-00	00450 ALBERT ST W	GUGLIELMO MARCONI SOCIETY OF SAULT STE MARIE	RT>E/RT	C	22-042	(1,761.08)	(284.61)	(2,045.69)
050-014-048-00	00334 SECOND AVE	GAGNON, LESLEY CAROLINE	RT	D(ii)	22-043	(551.48)	(15.20)	(566.68)
<b>2023</b>								
010-008-121-00	01409 QUEEN ST E	MACDOUGALL, CHARLOTTE ANNE	RT	D(i)	23-001	Assessment Change via 2023 RfR		
010-050-058-00	00099 MEVILLE RD	MOLINA, AURA J	CT>RT	A	23-002	(2,887.17)	-	(2,887.17)
010-060-101-00	00505 RIVER RD	JOHNSON TERRANCE MICHAEL	RT	D(i)	23-003	(1,428.14)	(7.78)	(1,435.92)
020-025-034-00	00048 CRAWFORD AVE	O'DONNELL WILLIAM HAROLD B	RT	D(i)	23-004	(56.10)	-	(56.10)
020-045-027-00	00911 QUEEN ST E	2836295 ONTARIO INC	CT>RT	A	23-005	(5,390.88)	(33.01)	(5,423.89)
030-075-004-37	00000 MULBERRY ST	SAULT STE MARIE CITY	RT>E	C	23-006	(154.86)	(2.77)	(157.63)
030-075-011-93	00738 OLD GARDEN RIVER RD	GOUGH GEORGE MIRTON ESTATE	CT/CU>RT	A	23-007	(2,973.61)	-	(2,973.61)
030-075-041-00	00760 SECOND LINE E	ARK DEVELOPMENTS INC	CT	D(i)	23-008	(1,153.11)	-	(1,153.11)
030-085-116-00	00311 FOURTH LINE E	WATT DONALD JODY	CT/RT	A	23-009	Assessment Confirmed		
030-088-057-00	00302 FIFTH LINE E	SAULT STE MARIE CITY	RT>E/RT	C	23-010	(309.28)	-	(309.28)
040-006-019-00	00188 BLOOR ST W	BERTOLO STEPHEN	RT	D(i)	23-011	(1,187.25)	-	(1,187.25)
040-006-019-00	00188 BLOOR ST W	WARMCRETE HOMES INC	RT	D(i)	23-012	(600.63)	-	(600.63)
040-021-083-00	00124 DENNIS ST	SAULT STE MARIE HOUSING CORPORATION	RT	C	23-013	Assessment Confirmed		
040-030-040-00	00450 ALBERT ST W	GUGLIELMO MARCONI SOCIETY OF SAULT STE MARIE	RT>E	C	23-015	(4,273.25)	(92.97)	(4,366.22)
050-003-029-00	00714 SHARFER AVE	WESSEL KARL JOSEPH	RT	D(i)	23-016	(774.29)	-	(774.29)
050-021-070-00	00318 KINGSFORD RD	GUZZO-FOLIARO, MAURO	RT	D(i)	23-017	(636.64)	-	(636.64)
050-060-081-00	00708 BRULE RD	BOSTON ROBERT WILLIAM	RT	D(i)	23-018	(1,341.95)	(0.10)	(1,342.05)
050-070-047-29	00000 NOAH DR	SAULT STE MARIE CITY	RT>E	C	23-019	(31.53)	-	(31.53)
060-041-097-00	00006 AMHERST ST	HORVAT, TAYANA FRANCES	RT	D(i)	23-021	(222.79)	-	(222.79)
060-052-153-00	00943 FOURTH LINE W	SMITH SANDRA ANN	CT/RT>RT	A	23-022	(737.73)	-	(737.73)
060-070-114-21	00041 PARKEWOOD DR	SAULT STE MARIE CITY	RT>E	C	23-023	(858.62)	(20.70)	(879.32)
060-070-114-30	00005 PARKEWOOD DR	SAULT STE MARIE CITY	RT>E	C	23-024	(800.83)	(19.62)	(820.45)
060-085-080-00	00261 POINTE LOUISE DR	FLAMMIA FRANCESCO	RT	D(i)	23-025	(2,790.52)	-	(2,790.52)
060-085-098-00	00151 POINTE LOUISE DR	LUKENDA JANICE	RT	D(i)	23-026	(6,736.88)	(9.13)	(6,746.01)
<b>Application(s) Denied:</b>								
030-056-0152-01	00333 GREAT NORTHERN RD	INNVEST PROPERTIES CORP	CT	G	23-027	-	-	-

**REPORT TOTAL \$ (40,559.61) \$ (548.94) \$ (41,108.55)**

- A. CEASES TO BE LIABLE FOR TAX AT RATE IT WAS TAXED
- B. BECAME VACANT OR EXCESS LAND
- C. BECAME EXEMPT
- D. SICKNESS OR EXTREME POVERTY

- D(i). RAZED BY FIRE, DEMOLITION OR OTHERWISE
- D(ii). DAMAGED AND SUBSTANTIALLY UNUSABLE
- E. MOBILE UNIT REMOVED
- F. GROSS OR MANIFEST CLERICAL/FACTUAL ERROR
- G. REPAIRS/RENO'S PREVENTING NORMAL USE (MIN 3 MONTHS)

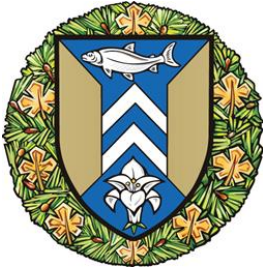

The Corporation of the  
City of Sault Ste. Marie  
**COUNCIL REPORT**

June 19, 2023

TO: Mayor Matthew Shoemaker and Members of City Council  
AUTHOR: Lisa Petrocco, CPA, CGA – Manager of Taxation  
DEPARTMENT: Corporate Services  
RE: Registration of Tax Arrears Certificate(s) and Sale

---

**Purpose**

Staff is seeking Council approval to proceed with the registration of tax arrears certificates and sale in accordance with the *Municipal Act, 2001*.

**Background**

Attached is a listing of properties recommended for the registration of tax arrears certificates and sale.

The steps in the tax sale process are as follows:

1. City Council endorses a resolution for the Manager of Taxation to proceed.
2. Manager of Taxation mails “Farm Mediation Service” notice to property owner, allowing assessed farmers a 15-day appeal forum.
3. Registration of Tax Arrears Certificate on title.
4. First Notice to owners and any other person(s) who may have an interest in the property within 60 days of registration.
5. Final Notice to owners and any other person(s) who may have an interest in the property within 280 days of registration.
6. Redemption period expires 365 days from the date of registration.
7. Begin advertising in the Ontario Gazette and in a newspaper that, in the opinion of the treasurer, has such circulation within the municipality as to provide reasonable notice of the sale.
8. Manager of Taxation conducts Tax Sale.
9. Preparation of documentation and registration of Tax Deeds for properties sold at the Tax Sale

**Analysis**

Not applicable.

**Financial Implications**

The properties listed represent \$440,867.04 in outstanding tax revenue.

**Strategic Plan / Policy Impact / Climate Impact**

Not applicable.

Registration of Tax Arrears Certificate(s) and Sale

June 19, 2023

Page 2.

**Recommendation**

It is therefore recommended that Council take the following action:

Resolved that the report of the Manager of Taxation dated June 19, 2023 be received and Council authorize the Manager of Taxation to commence Tax Sale proceedings as listed in the attached schedule be commenced in accordance with the *Municipal Act, 2001*.

Respectfully submitted,

Lisa Petrocco, CPA, CGA

Manager of Taxation

705.541.7065

[l.petrocco@cityssm.on.ca](mailto:l.petrocco@cityssm.on.ca)

CITY OF SAULT STE. MARIE - MUNICIPALITY 57-61  
LIST OF LANDS LIABLE TO BE SOLD FOR TAX ARREARS AS OF 2023 06 19  
IN ACCORDANCE WITH THE MUNICIPAL ACT, 2001  
PROPERTIES REGISTERED FOR TAX SALE 2024

PARCEL NO.	ROLL NUMBER	PROPERTY ADDRESS	PROPERTY DESCRIPTION	TAX CLASS	ASSESSMENT	TOTAL TAXES OUTSTANDING
1	010008026000000	00111 PARKDALE DR	PLAN H504 LOT 26	RT	\$ 305,000	\$ 18,592.70
2	010039006000000	00124 EAST CHAMPAGNE DR	PLAN 1M487 LOT 31 PCL 31-1 SEC 1M487	RT	\$ 247,000	\$ 18,610.77
3	010057048410000	00020 WOODLAWN AVE	PLAN 1M495 LOT 22 PCL 22-1 SEC 1M495	RT	\$ 274,000	\$ 20,233.86
4	020005141000000	00433 ELIZABETH ST	PLAN 52239 LOT 25	RT	\$ 154,000	\$ 9,785.11
5	020017095000000	00140 WOODWARD AVE	PLAN 149 S PT LOT 5	RT	\$ 133,000	\$ 8,750.57
6	020032118000000	00015 LAURIER PL	PLAN 285 BLK 20 LOT 8 PT	RT	\$ 173,000	\$ 9,719.08
7	020041004000000	00701 QUEEN ST E	PLAN 323 LOT 6 LOT 7 LOT 8PT FORM 2	CT	\$ 142,000	\$ 24,878.30
8	020042023000000	00531 ALBERT ST E	PLAN 2251 PT LOTS 5 AND 6	CT	\$ 196,000	\$ 29,699.58
9	020042178000000	00685 QUEEN ST E	PLAN 732 LOT 1	CT/RT	\$ 224,000	\$ 35,883.70
10	030082048000000	01280 THIRD LINE E	SEC 21 SE1/4 PT PCL 3265 AWS RP 1R8808 PART 1	RT	\$ 375,000	\$ 18,531.95
11	030085150030000	00257 GLENGARY GATE CRES	PLAN 1M594 LOT 1	RT	\$ 541,000	\$ 38,893.53
12	040007050000000	00160 KEHOE AVE	PLAN 1489 LOT 279 PT LOT 280 PT	RT	\$ 89,000	\$ 6,991.62
13	040012001000000	00358 NORTH ST	PLAN 681 LOT 134SPT TO LOT 136SPT	RT	\$ 159,000	\$ 11,966.30
14	040015011000000	00441 CHARLES ST	PLAN 402 BLK 5 LOT 77	RT	\$ 113,000	\$ 9,018.87
15	040016071000000	00315 HURON ST	PLAN 727 LOT 30 PT	RT	\$ 82,000	\$ 4,880.51
16	040020114000000	00009 RAILROAD AVE	PLAN 19938 LOT 546 LOT 547	RT	\$ 139,000	\$ 8,127.98
17	040027095000000	00209 GLOUCESTER ST	PLAN 1784 S PT LOT 4 S PT LOT 5	RT	\$ 62,000	\$ 3,770.86
18	040029061000000	00246 HURON ST	PLAN 727 LOT 139	RT	\$ 99,000	\$ 5,402.92
19	040029088000000	00267 ST JAMES ST	PLAN 727 LOT 185	RT	\$ 83,000	\$ 5,125.41
20	040031011000000	00633 QUEEN ST W	PLAN TP ST MARY'S PT LOTS 4 AND 5 S SUPERIOR ST	RT	\$ 160,000	\$ 12,337.16
21	040031081000000	00475 QUEEN ST W	PLAN 1255 LOT 21PT	RT	\$ 82,000	\$ 6,188.22
22	050006046000000	00583 SHERBOURNE ST	PLAN 1749 LOT 405 LOT 404PT	RT	\$ 56,000	\$ 44,643.82
23	050009014000000	00137 WALLACE TERR	PLAN 1749 LOT 84	RT	\$ 92,000	\$ 6,960.24
24	050013059000000	00500 WALLACE TERR	PLAN M30 LOT 147 LOT 148PT RP 1R1602 PART 1 TO PART 3 PCL 1690 396 5626 AWS CLOSED LANE PT	RT	\$ 142,000	\$ 11,625.85
25	050013136000000	00277 SIXTH AVE	PLAN M30 LOT A PT LOT 113 PT LANE AND PLAN AR966 PT PART 2 RP 1R13455 PART 3 PCLS 283 676 SECAWS	RT	\$ 110,000	\$ 8,066.06
26	050016014000000	00435 FIRST AVE	PLAN 6503 LOT 362PT LOT 363 PT	RT	\$ 125,000	\$ 7,065.86
27	060016095000000	00041 ALFRED ST	PLAN 2674 LOTS 99 TO 101	RT	\$ 126,000	\$ 19,971.03
28	060028046000000	00282 BORDEN AVE	PLAN 7882 LOT 536 LOT 537 CLOSED LANE	RT	\$ 190,000	\$ 13,833.33
29	060029006000000	00791 SECOND LINE W	PLAN 7882 PT LOTS 74 TO 76	RT	\$ 140,000	\$ 7,634.08
30	060070055000000	00405 SUNNYSIDE BEACH RD	PLAN M172 LOT 24 PCL 5565 AWS	RT	\$ 249,000	\$ 13,677.77
						<b>\$ 440,867.04</b>

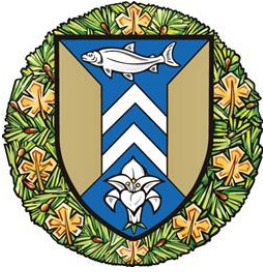

**The Corporation of the  
City of Sault Ste. Marie**

**C O U N C I L   R E P O R T**

June 19, 2023

TO: Mayor Matthew Shoemaker and Members of City Council  
AUTHOR: Ida Bruno, Labour Relations Coordinator  
DEPARTMENT: Corporate Services  
RE: Memorandum of Settlement for CUPE 67 Civic Centre

---

**PURPOSE**

The purpose of this report is to recommend the approval of the attached Memorandum of Settlement for CUPE Local 67 Civic Centre.

**BACKGROUND**

The City, through the collective bargaining process, has reached a Memorandum of Settlement with the aforementioned unionized group for a five (5) year term.

**ANALYSIS**

The highlights of the settlement are as follows:

***CUPE Local 67 (Civic Centre)***

- Average annual increase to budget of 3.47% (inclusive of wage and benefit increases)
- Minor benefit enhancements
- Recognition of National Truth and Reconciliation Day
- Improvements to contract language and vacation allocation/language
- Commitment to explore alternate work arrangements (hybrid/compressed schedule)

**FINANCIAL IMPLICATIONS**

The financial impact of these settlements for 2023 can be accommodated in the contingency reserve provided for that purpose in the 2023 Budget. Future years' impacts will be outlined in the budget deliberations for those years. Please note:

- The increase to vacation consists of one extra day for the group that have been with the Corporation from 7-9 years.
- Financial implications of any new work schedule will be set out in the operating proposal to be developed for consideration by the Senior Management Team.

Memorandum of Settlement for CUPE 67 Civic Centre

June 19, 2023

Page 2.

### **STRATEGIC PLAN / POLICY IMPACT**

This item applies to the Service Delivery focus area of the Corporate Strategic Plan.

### **RECOMMENDATION**

It is therefore recommended that Council take the following action:

Resolved that the report of the Labour Relations Coordinator dated June 19, 2023 be received and that City Council ratify the Memorandum of Settlement for CUPE Local 67 – Civic Centre.

Respectfully submitted,

Ida Bruno, CHRL  
Labour Relations Coordinator  
705.759.5449  
[i.bruno@cityssm.on.ca](mailto:i.bruno@cityssm.on.ca)

MEMORANDUM OF SETTLEMENT

THE CORPORATION OF THE CITY OF SAULT STE. MARIE  
&  
CUPE LOCAL 67 CIVIC CENTRE

1. The parties herein agree to the terms of the memorandum as constituting full and final settlement of all matters in dispute.
2. The undersigned representatives of the parties do hereby agree to recommend complete acceptance of all the terms of this memorandum to their respective principals.
3. The parties herein agree that the term of the collective agreement shall be from February 1, 2023 to January 31, 2028.
4. Retroactivity will only apply to the Wage Schedule. All other terms negotiated will be in effect the 1<sup>st</sup> of the following month after ratification by both parties.
5. It is understood that student wages will be established corporately and that no retroactivity will be paid out. Student wages are not subject to the Wage Schedule increases.
6. The parties herein agree that the said collective agreement shall include the terms of the previous collective agreement which expired on January 31, 2023 provided, however, that the following amendments are incorporated in Appendix 1.

Signed this 1<sup>st</sup> day of June, 2023.

For the Union

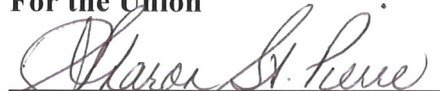
  
Sharon St. Pierre

  
Michelle Quinton

  
Kevin Lavergne

\_\_\_\_\_  
Paul Edwards

For the Employer

  
Ida Bruno

  
Nicole Ottolino

  
Peter Tonazzo

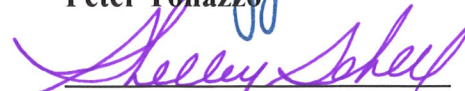
  
Shelley Schell

  
Carl Rumiel

  
Justine Palmer

# Appendix 1



Sign Off Sheet #1  
CUPE Local 67 Civic Centre  
&  
The City of Sault Ste. Marie

**Article 12:01**

**EXISTING LANGUAGE**

The City agrees to post all permanent vacancies, which occur within the bargaining unit for a period of not less than five (5) working days.

The City further agrees not to hire new employees for jobs posted until the job posting time limit of five (5) working days has expired. Any employee wishing to make application shall do so within the required time limit in writing. All applications will be acknowledged within fourteen (14) days of receipt in writing.

**AGREED TO LANGUAGE**

The City agrees to post all permanent vacancies, which occur within the bargaining unit for a period of not less than five (5) working days.

**The new position or vacancy may also be advertised externally during the period of the internal posting. The Employer agrees that no external applicant will be considered for the positions until all internal applicants are first considered.**

Any employee wishing to make application shall do so within the required time limit in writing. All applications will be acknowledged within fourteen (14) days of receipt in writing.

**Article 14:05 Paid Approved Union Leave**

**EXISTING LANGUAGE**

The City agrees to maintain the wages of an employee on Paid Approved Union Leave subject to the following conditions:

The Union has confirmed that it will provide WSIB coverage for members on Leave for Union Business. The Union shall provide to the City initially and at any time upon request thereafter its WSIB Clearance Certificate to verify it has such valid coverage. The Union shall also provide to the City its WSIB account number. It is the responsibility of the Union to maintain such coverage. Failure of the Union to maintain such coverage shall make this agreement null and void.

The City will not be responsible for WSIB coverage when an employee is on such leave.

The Union will promptly reimburse the City within thirty (30) days of the date of the invoice for the amounts owing for such leaves.

The City will issue such invoices on a frequency of no greater than once per month.

For each employee granted such leave, it will appear as a separate code (Paid Approved Union Leave - P.A.U.L.) on the employee's pay stub and the City shall invoice for reimbursement from the respective Union the amount of wages, Employer Health Tax, City OMERS share, City share of CPP and City share of EI.

For approved leaves of twenty (20) working days or more, the Union shall also reimburse the City the monthly benefit premiums for Extended Health Care, Dental Plan, Life & ADD, and LTD. Also, the City will invoice for the applicable vacation entitlement percentage (2% per week of vacation entitlement) for the period of absence plus a Sick Leave reimbursement amount of 1.5 day's pay for each twenty (20) working days absence.

In addition to the previously noted amounts, the City shall bill the Union on each invoice the amount of one (1) hour at the CUPE 67 Civic JC 12 Level 4 rate for the preparation of such invoice.

The City shall send the invoice for such reimbursement to the address designated by the Union. The Union has confirmed that invoices for all CUPE Locals will be sent to CUPE, Sault Ste. Marie Area Office, 421 Bay Street, Suite 606, Sault Ste. Marie, Ontario, POA 1X3.

Requests for Leave for Union Business approved by a representative of the Union shall be on a form provided by the City for approval by the respective Department Head and distributed to the Accounting Division with a copy to the Human Resources Department.

### **AGREED TO LANGUAGE**

The City agrees to maintain the wages of an employee on Paid Approved Union Leave subject to the following conditions:

The Union has confirmed that it will provide WSIB coverage for members on Leave for Union Business. **Where possible, the Union shall provide the City with one week's notice of such Leave.** The Union shall provide to the City initially and at any time upon request thereafter its WSIB Clearance Certificate to verify it has such valid coverage. The Union shall also provide to the City its WSIB account number. It is the responsibility of the Union to maintain such coverage. Failure of the Union to maintain such coverage shall make this

agreement null and void. The City will not be responsible for WSIB coverage when an employee is on such leave.

The Union will promptly reimburse the City within thirty (30) days of the date of the invoice for the amounts owing for such leaves.

The City will issue such invoices on a frequency of no greater than once per month.

For each employee granted such leave, it will appear as a separate code (Paid Approved Union Leave - P.A.U.L.) on the employee's pay stub and the City shall invoice for reimbursement from the respective Union the amount of wages, Employer Health Tax, City OMERS share, City share of CPP and City share of EI.

For approved leaves of twenty (20) working days or more, the Union shall also reimburse the City the monthly benefit premiums for Extended Health Care, Dental Plan, Life & ADD, and LTD. Also, the City will invoice for the applicable vacation entitlement percentage (2% per week of vacation entitlement) for the period of absence plus a Sick Leave reimbursement amount of 1.5 day's pay for each twenty (20) working days absence.

In addition to the previously noted amounts, the City shall bill the Union on each invoice the amount of one (1) hour at the CUPE 67 Civic JC 12 Level 4 rate for the preparation of such invoice.

The City shall send the invoice for such reimbursement to the address designated by the Union. The Union has confirmed that invoices for all CUPE Locals will be sent to CUPE, Sault Ste. Marie Area Office, 421 Bay Street, Suite 606, Sault Ste. Marie, Ontario, POA 1X3.

Requests for Leave for Union Business approved by a representative of the Union shall be on a form provided by the City for approval by the respective Department Head and distributed to the Accounting Division with a copy to the Human Resources Department. **It is understood that such leave will not interfere with the operations of any one department but such leave shall not be unreasonably withheld.**

### **Article 23:15**

Temporary Transfer Opportunities ✓

### **EXISTING LANGUAGE**

If a temporary employment opportunity exists within a Department and the Department deems it necessary to hire a temporary employee, prior to proceeding to hire from the outside labour market, a "Notice of Temporary Transfer Opportunity" will be posted for three (3) days.

The City will post temporary vacancies when it is known at the time the vacancy occurs to be greater than three (3) months in duration. If an extension of three (3) months or more is required with respect to the temporary vacancy, such temporary vacancy shall be posted. It is understood there shall be only one (1) such extension.

Permanent employees who wish to be considered for such temporary transfer opportunities must respond to the Notice.

It is understood that selection of interested employees will be at the discretion of the Department.

Employees while temporarily transferred will not be considered for any other temporary transfer opportunities.

Temporary transfers are subject to the terms and conditions of article 23:14 and are also subject to the mutual agreement of the Department Heads concerned. Employees temporarily transferred must accept a lower pay scale if transferred to a lower rated classification.

A Notice of Temporary Transfer shall not be required for temporary job opportunities of less than three (3) months duration.

It is agreed and understood that the application of this letter and any selection of employees for temporary transfer will not be subject to the grievance procedure.

### **AGREED TO LANGUAGE**

If a temporary employment opportunity exists within a Department and the Department deems it necessary to hire a temporary employee, prior to proceeding to hire from the outside labour market, a "Notice of Temporary Transfer Opportunity" will be posted for three (3) days.

The City will post temporary vacancies when it is known at the time the vacancy occurs to be greater than three (3) months in duration. If an extension of three (3) months or more is required with respect to the temporary vacancy, such temporary vacancy shall be posted. It is understood there shall be only one (1) such extension.

Permanent employees who wish to be considered for such temporary transfer opportunities must respond to the Notice.

It is understood that selection of interested employees will be at the discretion of the Department.

Employees while temporarily transferred will not be considered for any other temporary transfer opportunities. **Employees who are on probation shall not be allowed to temporarily transfer within their probationary period.**

**LOUs to be renewed:**

3, 4

SIGNED AT SAULT STE. MARIE this 31 day of January, 2023

FOR C.U.P.E LOCAL 67

Michelle Levent  
Azy  
Sharon Spence  
[Signature]

FOR CITY

[Signature]  
Michelle Ottolano  
Shelby Sebel  
[Signature]  
Pozzop  
Duro

**LETTER #3**

**LETTER OF UNDERSTANDING**

**Between**

**THE CITY OF SAULT STE. MARIE**

**and**

**LOCAL 67 C.U.P.E**

**ACCOMMODATIONS**

The Return-to-Work Coordinator or Designate will request the attendance of a Union Representative\* at a meeting required for the accommodation of an employee with:

- a) A permanent disability; or
  - b) A temporary disability known at the outset to be for a duration greater than thirty (30) days.
- \*The Union shall designate the representative(s) to deal with disability related matters. Unavailability or non-attendance of the designated Union representative at meetings arranged by the Return-to-Work Coordinator or designate shall not delay the accommodation process.
  - \*Either party may request a re-scheduling of a meeting with notice to the other party within five (5) days of such meeting being scheduled.
  - Both parties recognize the benefits of early and safe return to work and the parties endeavor to schedule meetings to deal with such matters as promptly as possible.

The Union can propose alternative accommodations including entry-level positions.

It is understood the employee and Union will be provided with a reasonable amount of time to consider and respond to a proposed permanent disability accommodation.

The Return-to-Work Coordinator or designate will arrange quarterly meetings with the designated Union Representative to review accommodation activity.

Signed at Sault Ste. Marie this 31 day of January, 2023.

FOR C.U.P.E LOCAL 67

Key  
[Signature]  
Sharon St. Pierre  
Michelle Quinton

FOR CITY

Ida Bruno  
Mary Ottolino  
Shelley Scheel  
[Signature]  
P. Japp  
D. Howe

LETTER #4

LETTER OF UNDERSTANDING

Between

THE CITY OF SAULT STE. MARIE

and

LOCAL 67 C.U.P.E

JOB EVALUATION SYSTEM REVIEW

The parties agree to meet at a minimum once per year during the term of the collective agreement to review jobs under the Job Evaluation system as well as any other system(s) the parties may wish to discuss.

The parties may by mutual agreement during the course of the collective agreement agree to replace the existing Job Evaluation System with a new system.

Signed at Sault Ste. Marie this 31 day of January, 2023.

FOR C.U.P.E LOCAL 67

[Signature]  
[Signature]  
Marion St. Pierre  
Michelle Quinton

FOR CITY

[Signature]  
Marie-Ottoline  
[Signature]  
[Signature]  
P. Boyce  
[Signature]



Sign Off Sheet #2  
CUPE Local 67 Civic Centre  
&  
The City of Sault Ste. Marie

**Article 3:05**

**EXISTING LANGUAGE**

3:05 New Employees a) The Employer agrees to acquaint new employees with the fact that a Union Agreement is in effect and with the conditions of employment set out in the Articles dealing with Union Security and Dues Check-off.

**AGREED TO LANGUAGE**

3:05 New Employees a) The Employer agrees to acquaint new employees with the fact that a Union Agreement is in effect and with the conditions of employment set out in the Articles dealing with Union Security and Dues Check-off.

**A representative of the Union shall be able to meet with new members during work time to introduce themselves and provide the new CUPE Local 67 employee a CUPE Local 67 welcome package. This introduction shall not exceed fifteen (15) minutes in duration**

**Article 12:04**

**EXISTING LANGUAGE**

The City agrees to forward to the Secretary-Treasurer of the Union the monthly salary of all new employees and also change in any salary of existing employees.

**AGREED TO LANGUAGE**

The City agrees to forward to the Secretary-Treasurer of the Union the ~~monthly salary~~ **hourly wage** of all new employees and also change in any salary of existing employees.

**Letter #2 to be renewed**



SIGNED AT SAULT STE. MARIE this 1<sup>st</sup> day of May, 2023

FOR C.U.P.E LOCAL 67

FOR CITY

Alison St. Pierre

John Brune

Uy

Wade Ottolino

Kim Lavigne

P. J. Jyp

Sherry Schell

C. C. S

Justin Palen

Sign Off Sheet #3  
CUPE Local 67 Civic Centre  
&  
The City of Sault Ste. Marie

**ARTICLE 3- NEW LANGUAGE**

**3.06 Information for Union:**

- a) **The City shall provide the Union, monthly, with an electronic contact list in excel of all employees in the bargaining unit. The contact list will include:**
- a. **home address**
  - b. **home phone number or cell number**
  - c. **work email address and where available a personal email address**

**ARTICLE 7 – DISCRIMINATION**

**CURRENT LANGUAGE**

7:01 The City, the Union, and their agents agree not to discriminate against any employee because of their membership in the Union, Union Officer and/or for any reason as set out in the Ontario Human Rights Code.

**PROPOSED LANGUAGE**

7:01 The City, the Union, and their agents agree **that there shall be no discrimination or harassment** against any employee because of their membership in the Union, **their duties as a** Union Officer, and/or for any reason as set out in the Ontario Human Rights Code.

**CURRENT LANGAUGE**

11:06 A temporary vacancy is defined as a vacancy scheduled to be up to eight (8) months in duration. Twelve (12) month temporary absences will be applied to Maternity, Paternity and Sick Leave absences and the related “domino” or cascade vacancies.

It is understood that in cases of ESA protected leaves, such as temporary vacancies will automatically extend for the duration of said legislative leaves.

**PROPOSED LANGUAGE**

**11:06 A temporary vacancy is defined as a vacancy scheduled to be up to eight (8) months in duration.**

It is understood that in cases of ESA protected leaves, such temporary vacancies and the related domino or cascade vacancies (if any) will automatically extend for the duration of said legislative leaves.

Article 16:08

CURRENT LANGUAGE

16:08 An employee may accumulate annual vacation over a two year period, with Department Head and Chief Administrative Officer approval.

PROPOSED LANGUAGE

16:08 An employee may accumulate annual vacation over a two year period, **but may only carry over up to one week into the next calendar year without approval from a Department Head. Any carry over greater than one week, up to a maximum of two weeks, must be approved by the Department Head and Director of Human Resources.**

The application to carry over holidays from one year to another must be submitted in writing to the head of the Department before October 15<sup>th</sup> of that year.

SIGNED AT SAULT STE. MARIE this 29<sup>th</sup> day of March, 2023

FOR C.U.P.E LOCAL 67

FOR CITY

Michelle Quinlan

Ida Bruno

Sharon St Pierre

Sherry Sebel

Kevin Zwarg

Walter Attolano

[Signature]

[Signature]

[Signature]

[Signature]

Sign Off Sheet #4  
CUPE Local 67 Civic Centre  
&  
The City of Sault Ste. Marie

**Article 14:08 JURY DUTY**

**ORIGINAL**

14:08 The City shall grant leave of absence without loss of seniority to an employee who serves as a juror in the District of Algoma. The City shall pay such employee the difference between their normal earnings and the payment they receives for jury service excluding payment for traveling, meals or other expenses. The employee will present proof of service and the amount of pay received.

**PROPOSED**

**NOTICE & HOUSEKEEPING**

**The City intends to follow and enforce the practice dictated within the language of this Article.**

14:08 The City shall grant leave of absence without loss of seniority to an employee who serves as a juror in the District of Algoma. The City shall pay such employee the difference between their normal earnings and the payment they receives for jury service excluding payment for traveling, meals or other expenses. The employee will present proof of service and the amount of pay received.

**Article 20:00 PENSIONS**

**E ORIGINAL**

20:02 The Corporation shall provide all eligible full-time employees with the O.M.E.R.S. Benefit Type 1 Supplementary Benefit (past service with the Corporation).

**PROPOSED**

20:02 The Corporation shall provide all eligible full-time employees with  the O.M.E.R.S. ~~Type 1 Supplementary Benefit (past service with the Corporation).~~ **All part-time employees shall be given the option to enroll.**

## Article 21 SAFETY PROVISIONS

### E ORIGINAL

21:02 All permanent employees required to wear safety footwear in the performance of their duties will be provided an annual allowance of two hundred (\$200.00) dollars for the purchase of one (1) pair of C.S.A. approved safety boots. All new employees will be provided with the boot allowance on successful completion of their probationary period.

Any employee completed their probationary period will receive 50% of their respective entitlement above, the first of the month following the completion of probation. The balance will be paid on June 30<sup>th</sup>.

For inside office (PWT Support Staff) workers will be eligible for a one (1) time allowance for the life of the agreement of one hundred eighty (\$180.00) dollars.

Where an employee is required to wear safety footwear on an occasional basis, the annual allowance for safety footwear will be granted on an "as needed basis." The boot allowance will be paid by June 30<sup>th</sup> each year.

The City is prepared to arrange for employees designated by the City within the Engineering Division to be provided annually with one (1) voucher to obtain one (1) pair of coveralls or two (2) t-shirts (safety blaze orange) at a supplier designated by the City.

### PROPOSED

21:02 All permanent employees required to wear safety footwear in the performance of their duties will be provided **with reimbursement up to a maximum** of ~~two hundred (\$200.00)~~ **two hundred and fifty (\$250.00)** dollars **per calendar year** for the purchase of one (1) pair of C.S.A. approved safety boots. **All employees will be required to provide proof of purchase in order to be reimbursed up to the maximum amount of two hundred and fifty (\$250.00) dollars.** All new employees will be provided with the boot allowance on successful completion of their probationary period.

~~Any employee completed their probationary period will receive 50% of their respective entitlement above, the first of the month following the completion of probation. The balance will be paid on June 30<sup>th</sup>.~~

**Any new employee who is required to purchase a pair of C.S.A. approved safety boots will be reimbursed up the maximum of two hundred and fifty**

**(\$250.00) dollars. Should the employment be terminated prior to the end of the probationary period, the City shall recover the cost of the safety boot reimbursement in their final pay**

~~For office (PWT Support Staff) workers will be eligible for a one (1) time allowance for the life of the agreement of one hundred eighty (\$180.00) dollars.~~

Where an employee is required to wear safety footwear on an occasional basis, the annual allowance **reimbursement** for safety footwear will be granted on an "as needed basis" **as approved by the Supervisor**. ~~The boot allowance will be paid by June 30<sup>th</sup> each year.~~

The City is prepared to arrange for employees designated by the City within the Engineering Division to be provided annually with one (1) voucher to obtain one (1) pair of coveralls or two (2) t-shirts (safety blaze orange) at a supplier designated by the City.

#### **Article 22:00 CAR ALLOWANCE MILEAGE REIMBURSEMENT**

##### **ORIGINAL**

22:01 Upon the written authority of a Department Head an employee may be permitted to use their own car for travel in the performance of employer's work for the City. Employees shall provide daily readings of mileage traveled on behalf of the City.

##### **PROPOSED**

22:01 Upon the **written** authority of a Department Head an employee may be permitted to use their own car for travel in the performance of employer's work for the City. ~~Employees shall provide daily readings of mileage traveled on behalf of the City.~~

---

##### **ORIGINAL**

22:02 Invoices must be submitted on the first of each month to the Head of the Department for approval showing the number of kilometers traveled on City business.

##### **PROPOSED**

22:02 **Mileage Claim Forms** must be submitted **periodically, but no fewer than once per calendar year by December 31<sup>st</sup>** to the Head of the Department for approval showing the number of kilometers traveled on City business.

## **UNION PROPOSAL**

### **ARTICLE 13- TRANSFER TO TEMPORARY POSITION OUTSIDE BARGAINING UNIT**

#### **Current Language**

13:01 If an employee is appointed by the City to a position outside of the scope of the bargaining unit, such employee shall retain their bargaining unit seniority for a period of twelve (12) months following such appointment.

No employee shall be transferred to a position outside the bargaining unit without their written consent.

If the employee remains in the position outside the scope of the bargaining unit beyond the above-noted twelve (12) month period or an accumulation of twelve (12) months, all bargaining unit seniority shall be removed from the bargaining unit seniority list. In the event the employer wishes to extend the period outlined above, the union must agree with the extension.

If the employee returns to the bargaining unit before the above-noted twelve (12) month period, they shall resume accumulation from the date of their return to the bargaining unit and shall be credited with the seniority held immediately prior to the appointment. During the period that the employee's bargaining unit seniority is being held by the bargaining unit while the employee is in a position outside of the bargaining unit, the amount of dues deducted will be calculated based on the employee's supervisory position hourly rate of pay as per Article 23 for all hours worked in the position outside of the bargaining unit.

#### **Proposed Language:**

13:01 If an employee is appointed by the City to a position outside of the scope of the bargaining unit, such employee shall retain their bargaining unit seniority for a period of twelve (12) months following such appointment.

No employee shall be transferred to a position outside the bargaining unit without their written consent.

If the employee remains in the position outside the scope of the bargaining unit beyond the above-noted twelve (12) month period or an accumulation of twelve (12) months, all bargaining unit seniority shall be removed from the bargaining



unit seniority list. In the event the employer wishes to extend the period outlined above, the union must be in agreement with the extension. **The Employer may extend the period above for transfers covering a leave protected under the Employment Standards Act but such extension shall not extend beyond 18 months, unless otherwise agreed to by the Union.**

If the employee returns to the bargaining unit before the above-noted twelve (12) **to eighteen (18)** month period **(for ESA protected leaves)**, they shall resume accumulation from the date of their return to the bargaining unit and shall be credited with the seniority held immediately prior to the appointment. During the period that the employee's bargaining unit seniority is being held by the bargaining unit while the employee is in a position outside of the bargaining unit, the amount of dues deducted will be calculated based on the employee's supervisory position hourly rate of pay as per Article 23 for all hours worked in the position outside of the bargaining unit.

SIGNED AT SAULT STE. MARIE this 1<sup>st</sup> day of May, 2023

FOR C.U.P.E LOCAL 67

Charles St. Pierre  
May  
[Signature]  
Kevin Lavigne

FOR CITY

Ida Bruno  
P. S. Gyp  
[Signature]  
Keely Schell  
Wade Ottolenghi  
Justin Palmer

**Sign Off Sheet #5**  
**CUPE Local No. 67 – Civic Centre**  
**&**  
**The City of Sault Ste. Marie**

**ARTICLE 15 – REGULAR HOURS OF WORK AND WORKING CONDITIONS**

**EXISTING LANGUAGE**

15:05 The Corporation shall pay a meal allowance of \$12.50 (effective the first of the month following ratification of the Memorandum of Settlement by the Parties) and increase to \$12.75 effective Feb. 1, 2016, \$13.00 effective Feb. 1, 2017 and \$13.25 effective Feb. 1, 2018 for an employee required to work ten (10) hours or more and an additional meal allowance for every five (5) hours he is required to work thereafter. In addition, the Corporation shall pay a meal allowance as outlined in the preceding sentence for an employee required to work five (5) consecutive hours on a call-out.

**NEW LANGUAGE**

15:05 The Corporation shall pay a meal allowance of ~~\$12.50~~ **fifteen dollars (\$15.00)** (effective the first of the month following ratification of the Memorandum of Settlement by the Parties) ~~and increase to \$12.75 effective Feb. 1, 2016, \$13.00 effective Feb. 1, 2017 and \$13.25 effective Feb. 1, 2018~~ for an employee required to work ten (10) hours or more and an additional meal allowance for every five (5) hours he is required to work thereafter. In addition, the Corporation shall pay a meal allowance as outlined in the preceding sentence for an employee required to work five (5) consecutive hours on a call-out.

**EXISTING LANGUAGE**

19.07 No member shall draw during their active service with the City, accumulated sick leave benefits if their absence from work is not due to illness as attested by the Certificate of a medical practitioner, if required by the Department Head.

The City shall pay up to forty dollars (\$40) for the completion of a City medical form when requested by the City. The employee shall be required to submit to their supervisor a receipt of payment in order to qualify for reimbursement.

Effective February 1, 2015, increase reimbursement of a City requested medical form up to fifty dollars (\$50).

**NEW LANGUAGE**

19.07 No member shall draw during their active service with the City, accumulated sick leave benefits if their absence from work is not due to illness as **attested supported** by the **approved** Certificate of a medical practitioner if required by the Department Head.

The City shall, **effective the 1<sup>st</sup> month following ratification of the Memorandum of Settlement by the parties** pay up to **sixty dollars (\$60)** ~~forty dollars (\$40) (effective Feb. 1, 2014 increase to forty five dollars (\$45))~~ for the completion of a City medical form when requested by the **employer City**. The employee shall be required to submit to their supervisor a receipt of payment in order to qualify for re-imbusement.

~~Effective February 1, 2015, increase reimbursement of a City requested medical form up to fifty dollars (\$50).~~

**EXISTING LANGUAGE**

20:02 The Corporation shall provide all eligible full-time employees with the O.M.E.R.S. Type 1 Supplementary Benefit (past service with the Corporation).

**NEW LANGUAGE**

20:02 The Corporation shall provide all eligible full-time employees with the O.M.E.R.S. **pension plan**. ~~Type 1 Supplementary Benefit (past service with the Corporation).~~ **All part-time employees shall be given the option to enroll.**

**ORIGINAL LANGUAGE**

22:03 When the said voucher is approved, the City will pay to the employee a car allowance of fifty three (\$.53) cents for each kilometer traveled on City business. The City agrees that where possible payment for mileage will be made by the 12<sup>th</sup> of the month.

It is agreed and understood that the Car Allowance shall not increase if it would result in exceeding the Canada Revenue Agency amount that would result in a taxable benefit.

**AGREED TO LANGUAGE**

22:03 When the said voucher ~~the Mileage Claim Form~~ is approved, the City will pay to the employee a car allowance ~~Mileage Reimbursement~~ equal to the Canada Revenue Agency (CRA) prescribed rate for mileage as amended from time to time. of fifty three (\$.53) cents ~~fifty-eight cents~~ for each kilometer traveled on City business. The City agrees that where possible payment for mileage will be made by the 12<sup>th</sup> of the month.

It is agreed and understood that the Car allowance shall not increase if it would result in exceeding the Canada Revenue Agency amount that would result in a taxable benefit.

**AGREED TO LANGUAGE**

**NEW ARTICLE**

**Right to have Steward Present**

**An employee shall have the right to have a representative of the Union present at a meeting which might be the basis of disciplinary action.**

SIGNED AT SAULT STE. MARIE this 29<sup>th</sup> day of May, 2023

FOR C.U.P.E LOCAL 67

[Signature]

Kevin Lavigne

Charles S. Faurie

Michelle Juntunen

FOR CITY

[Signature]

P. Jazzo

Sherry Abel

[Signature]

Wade Ottolino

Justin Palmer

**Sign Off Sheet #6**  
**CUPE Local No. 67 – Civic Centre**  
**&**  
**The City of Sault Ste. Marie**

**EXISTING LANGUAGE**

14.02 Bereavement

When death occurs to a member of an employee's immediate family, the employee will be granted leave of absence on compassionate grounds and will be granted time off with pay up to a maximum of four (4) working days for any days which are normally straight time working days and fall within the period from the day of the death up to and including the day following the funeral. If the funeral is more than four hundred kilometres (400 km) from Sault Ste. Marie, the five (5) working days shall be any days which are normally straight time working days and fall within the period from the day of the death up to and including the day following the funeral.

Immediate family means: mother, father, sister, brother, spouse, common-law spouse, son, daughter, grandchildren, grandparents, mother-in-law, father-in-law, grandparents-in-law. Leave of absence without loss of pay for four (4) working days shall be granted to an employee to attend the funeral of a child of a spouse as defined under per part (b) sections (i) and (iii) below.

Leave of absence without loss of pay for one (1) working day shall be granted to an employee to attend the funeral, or celebration of life of the employee's brother-in-law or sister-in-law, aunt and uncle.

"spouse" means a person

- (a) to whom the person is married, or
- (b) with whom the person is living outside marriage in a conjugal relationship, if the two persons,
  - (i) have cohabited for at least one year,
  - (ii) are together the parents of a child, or
  - (iii) have together entered into a cohabitation agreement under section 53 of the Family Law Act; ("conjoint").

**PROPOSED LANGUAGE**

**14:02 Bereavement Leave:**

When death occurs to a member of an employee's immediate family, the employee will be granted leave of absence on compassionate grounds and will be granted time off

with pay up to a maximum of four (4) working days for any days which are normally straight time working days and fall within the period from the day of the death up to and including the day following the funeral. If the funeral is more than ~~four hundred one~~ **four hundred and sixty** kilometres (400 km) **(160 km)** from Sault Ste. Marie, **the employee will be granted** the five (5) working days, **which** shall be any days ~~that~~ which are normally straight time working days and fall within the period from the day of the death up to and including the day following the funeral or celebration of life.

Immediate family means: ~~mother, father, sister, brother,~~ **parent, step-parent, sibling, child, step-child,** ~~son, daughter,~~ spouse, common-law spouse, ~~son, daughter,~~ grandparents, ~~mother-in-law, father-in-law,~~ **parent-in-law,** grandparents-in-law. Leave of absence without loss of pay for four (4) working days shall be granted to an employee to attend the funeral of a child of a spouse as defined under per part (b) sections (i) and (iii) below.

Leave of absence without loss of pay for one (1) working day shall be granted to an employee to attend the funeral, or celebration of life of the employee's ~~brother-in-law or sister-in-law~~ **sibling-in-law,** aunt and uncle, **niece or nephew.**

"spouse" means a person

(a) to whom the person is married, or

(b) with whom the person is living outside marriage in a conjugal relationship, if the two persons,

(i) have cohabited for at least one year,

(ii) are together the parents of a child, or

(iii) have together entered into a cohabitation agreement under section 53 of the Family Law Act; ("conjoint").

## **UNION PROPOSAL**

### **Current Language**

18:06 Coverage for Group Life Insurance and Long-Term Disability shall normally be adjusted effective on the first day of February following, but adjustments arising from the terms of a new or revised agreement shall be made effective as soon as possible after the signing of the terms of settlement. Coverage shall be in accordance with the terms and conditions of: Great West Life Assurance Co. Policy 320925 (Life Insurance) Great West Life Assurance Co. Policy 320925 (L.T.D.)

### **Proposed Language**

18:06 Coverage for Group Life Insurance and Long Term Disability shall normally be adjusted effective on the first day of February **May** following, but adjustments arising from the terms of a new or revised agreement shall be made effective as

soon as possible after the signing of the terms of settlement. Coverage shall be in accordance with the terms and conditions of: ~~Great West Life Assurance Co. Policy update 320925 (Life Insurance)~~ Great West Life Assurance Co. Policy ~~update 320925 (L.T.D.)~~ **Manulife Policy 121684.**

**ARTICLE 25 -CONTRACTING OUT**

**Current Language**

25.01 The parties hereby agree that there shall be no restriction on contracting out by the City of their work or services of a kind and to the degree now performed by employees represented herein, provided however, that no permanent employee who has completed four (4) years of service will be laid off due to contracting out.

**Proposed Language**

25.01 The parties hereby agree that there shall be no restriction on contracting out by the City of their work or services of a kind and to the degree now performed by employees represented herein, provided however, that no ~~permanent~~ employee who has completed four (4) **three (3)** years of **continuous** service will be laid off due to contracting out.

---

SIGNED AT SAULT STE. MARIE this 1<sup>st</sup> day of June, 2023

FOR C.U.P.E LOCAL 67

  
\_\_\_\_\_  
Michelle Zumb  
\_\_\_\_\_  
Sharon St. Pierre  
\_\_\_\_\_  
Kim Lavigne  
\_\_\_\_\_

FOR CITY

Ida Bruno  
\_\_\_\_\_  
[Signature]  
\_\_\_\_\_  
P. Toppo  
\_\_\_\_\_  
Shelley Scheel  
\_\_\_\_\_  
Wolke Ottolino  
\_\_\_\_\_  
Justin Palmer  
\_\_\_\_\_

**Sign Off Sheet #7**  
**CUPE Local 67 Civic Centre**  
**&**  
**The City of Sault Ste. Marie**  
**2022/2023 Negotiations Items**

**HOUSEKEEPING**

Replace his/her with gender neutral terminology (**their**)

**Article 15 – REGULAR HOURS OF WORK AND WORKING CONDITIONS**

**Letter of Understanding regarding alternative schedule will appear in the Minutes of Settlement only.**

**ARTICLE 16 – VACATION WITH PAY**

**CURRENT LANGUAGE**

- 16:01 All employees with less than 12 months service by December 31st, shall receive one day's vacation for each completed calendar month worked to a maximum of 10 days. Such vacation shall be taken in the following year with pay at 4% of the previous year's earnings.
- 16:02 (i) All employees who have completed one (1) calendar year of service and are in their second (2nd) year of service shall receive two (2) weeks plus one (1) day of annual vacation at their regular rate of pay.  
(ii) All employees who have completed who are in their third (3rd) year of service shall receive two (2) weeks plus two (2) days of annual vacation at their regular rate of pay.  
(iii) All employees who are in their fourth (4th) year of service shall receive two (2) weeks plus three (3) days of annual vacation at their regular rate of pay.
- 16:03 All employees who have completed four (4) calendar years of service and are in their fifth (5th) year of service, but less than ten (10) years of service shall be allowed three (3) weeks annual vacation at their regular rate of pay.
- 16:04 All employees who have completed nine (9) calendar years of service and are in their tenth (10th) year of service, but less than fifteen (15) years of service shall be allowed four (4) weeks annual vacation at their regular rate of pay.

2023 – Local 67 Civic Centre

Final Offer

Page 1 of 11



- 16:05 All employees who have completed fourteen (14) years of service and are in their fifteenth (15th) year of service, but less than twenty (20) years of service shall be allowed five (5) weeks annual vacation at their regular rate of pay.
- 16:06 All employees who have completed nineteen (19) calendar years of service and are in their twentieth (20th) year but less than twenty-five (25) years shall be allowed six (6) weeks annual vacation at their regular rate of pay.
- (b) All employees who have completed 25 calendar years of services and are in their 26th year shall be allowed six (6) weeks plus one (1) day.
- All employees who have completed 26 calendar years of services and are in their 27th year shall be allowed six (6) weeks plus one (2) days.
- All employees who have completed 27 calendar years of services and are in their 28th year shall be allowed six (6) weeks plus one (3) days.
- All employees who have completed 28 calendar years of services and are in their 29th year shall be allowed six (6) weeks plus one (4) days.
- 16:07 All employees who have completed twenty-nine (29) calendar years of service and are in their thirtieth (30th) year or more shall be allowed seven (7) weeks annual vacation at their regular rate of pay.

### PROPOSED LANGUAGE

- 16:01 All employees with less than 12 months service by December 31st, shall receive one day's vacation for each completed calendar month worked to a maximum of 10 days. Such vacation shall be taken in the following year with pay at 4% of the previous year's earnings.
- 16:02 (i) All employees who have completed one (1) calendar year of service and are in their second (2nd) year of service shall receive two (2) weeks plus one (1) day of annual vacation at their regular rate of pay.
- (ii) All employees who have completed **two (2) calendar years of service and who** are in their third (3rd) year of service shall receive two (2) weeks plus two (2) days of annual vacation at their regular rate of pay.
- (iii) All employees who **have completed three (3) calendar years of service and** are in their fourth (4th) year of service shall receive two (2) weeks plus three (3) days of annual vacation at their regular rate of pay.

~~16:03 All employees who have completed four (4) calendar years of service and are in their fifth (5th) year of service but less than ten (10) years of service shall be allowed three (3) weeks annual vacation at their regular rate of pay.~~

**16:03 (i) All employees who have completed four (4) calendar years of service and are in their fifth (5th) or sixth (6<sup>th</sup>) year of service shall be allowed three (3) weeks of annual vacation at their regular rate of pay.**

**(ii) All employees who have completed six (6) calendar years of service and are in their seventh (7th), eighth (8<sup>th</sup>) or ninth (9<sup>th</sup>) year of service shall be allowed three (3) weeks plus one (1) day of annual vacation at their regular rate of pay.**

16:04 All employees who have completed nine (9) calendar years of service and are in their tenth (10th) year of service, but less than fifteen (15) years of service shall be allowed four (4) weeks annual vacation at their regular rate of pay.

16:05 All employees who have completed fourteen (14) years of service and are in their fifteenth (15th) year of service, but less than twenty (20) years of service shall be allowed five (5) weeks annual vacation at their regular rate of pay.

16:06 All employees who have completed nineteen (19) calendar years of service and are in their twentieth (20th) year but less than twenty-five (25) years shall be allowed six (6) weeks annual vacation at their regular rate of pay.

(b) All employees who have completed 25 calendar years of services and are in their 26th year shall be allowed six (6) weeks plus one (1) days.

All employees who have completed 26 calendar years of services and are in their 27th year shall be allowed six (6) weeks plus ~~one~~ two (2) days.

All employees who have completed 27 calendar years of services and are in their 28th year shall be allowed six (6) weeks plus ~~one~~ three (3) days.

All employees who have completed 28 calendar years of services and are in their 29th year shall be allowed six (6) weeks plus ~~one~~ four (4) days.

16:07 All employees who have completed twenty-nine (29) calendar years of service and are in their thirtieth ( ~~30th~~ 30th) year or more shall be allowed seven (7) weeks annual vacation at their regular rate of pay.

## ARTICLE 17 – PAID HOLIDAYS

### CURRENT LANGUAGE

17:01 The following holidays shall be recognized as time off with pay for all regular employees:

New Year's Day  
Family Day (3rd Monday in February)  
Good Friday  
Easter Monday  
Victoria Day  
Canada Day  
Civic Holiday  
Labour Day  
Thanksgiving Day  
Remembrance Day  
Christmas Day  
Boxing Day

If any of the above holidays falls on a Saturday or Sunday, the Friday or the Monday as designated by the City shall be considered as the paid holiday for the purposes of this agreement.

Notwithstanding the above provision, where either Christmas or Boxing Day falls on a Saturday or Sunday, the designated days may be the two (2) days immediately preceding or following Christmas or Boxing Day.

Every employee shall be granted time off with pay at their regular rate of pay in respect to a paid holiday unless:

- (1) the employee is required to work on a paid holiday and does not work or leaves before the end of their shift without permission from the supervisor, or;
- (2) the employee does not work their last scheduled shift prior to or their first scheduled shift after the paid holiday unless they were off work due to illness or with permission, or;
- (3) subject to the provisions of the Employment Standards Act, the employee is on layoff on a paid holiday or;
- (4) subject to the provisions of the Employment Standards Act, the employee is on leave of absence on a paid holiday.

### **PROPOSED LANGUAGE**

17:01 The following holidays shall be recognized as time off with pay for all regular employees:

New Year's Day  
Family Day (3rd Monday in February)  
Good Friday  
Easter Monday  
Victoria Day  
Canada Day  
Civic Holiday  
Labour Day  
**National Day for Truth and Reconciliation**  
Thanksgiving Day  
Remembrance Day  
Christmas Day  
Boxing Day

If any of the above holidays falls on a Saturday or Sunday, the Friday or the Monday as designated by the City shall be considered as the paid holiday for the purposes of this agreement.

Notwithstanding the above provision, where either Christmas or Boxing Day falls on a Saturday or Sunday, the designated days may be the two (2) days immediately preceding or following Christmas or Boxing Day.

Every employee shall be granted time off with pay at their regular rate of pay in respect to a paid holiday unless:

- (1) the employee is required to work on a paid holiday and does not work or leaves before the end of their shift without permission from the supervisor, or;
- (2) the employee does not work their last scheduled shift prior to or their first scheduled shift after the paid holiday unless they were off work due to illness or with permission, or;
- (3) subject to the provisions of the Employment Standards Act, the employee is on layoff on a paid holiday or;
- (4) subject to the provisions of the Employment Standards Act, the employee is on leave of absence on a paid holiday.

## **Article 18 WELFARE PLAN**

### **CURRENT LANGUAGE**

18:01 It is agreed that the employees covered by this agreement will be provided with Green Shield benefits as listed:

- Ward Coverage
- Extended Health Care
  - Vision Care amount effective February 1 2020: \$450.00 / 24 month. (Note – this amount can be used for laser eye surgery.)
  - One (1) eye examination by a licensed ophthalmologist or optometrist every twenty-four (24) consecutive months.
  - Orthotics & orthopedic shoes maximum of one (1) pair \$400 per calendar year.
  - Pharmacy dispensing fees capped at \$10.00 and increase to \$11.00 effective February 1, 2013. No O.T.C. drug coverage with the exception of those deemed by the insurer to be "life sustaining".

Paramedical Benefit:

Maximum of \$1,100 per calendar year for any combination of the following services:

Physiotherapist, Clinical Psychologist or Marriage & Family Therapist, Massage Therapist, Speech Pathologist, Chiropractor, Osteopath, Podiatrist, Chiropodist, Naturopath, and Nutritional Counselling by Professional Dietician.

- Maximum of \$1000 per calendar year for Psychological Benefit (MSW, Registered Counsellor or Psychologist).
- Out of Province Travel Plan
- Dental Plan #9, with Rider #3 (Orthodontic, three thousand (\$3,000 limit), at current ODA rates minus one year.
- Overage Dependent Coverage is applied to the Green Shield Extended Health Care and the Dental Plan, 100% of the cost to be paid for by the City. It is agreed that the full U.I.C. rebate on premiums shall be retained by the City.

Coverage for new employees shall be effective as follows:

- (a) Extended Health Care – 1<sup>st</sup> day the month following date employed.
- (b) Dental – 1<sup>st</sup> day of the month following completion of three (3) months service.

• **12 Month Pregnancy/Parental Replacement Temporary Employees – Limited Benefit Coverage**

Prescription Drug Benefit Plan at 90%/10% Co-Insurance (Plan subject to elimination of OTC's and \$8 Dispensing Fee Cap and effective February 1, 2014 increase to \$10.)

Vision Care - \$125 (effective 1<sup>st</sup> of the month following ratification) per 24 months

### PROPOSED LANGUAGE

18:01 It is agreed that the employees covered by this agreement will be provided with Green Shield benefits as listed:

- Ward Coverage
- Extended Health Care
  - Vision Care amount effective February 1 2020 ~~2023~~: ~~\$450.00~~ **\$475.00** and **\$500.00 (effective February 1, 2024)** / 24 month. (Note – this amount can be used for laser eye surgery).
  - One (1) eye examination by a licensed ophthalmologist or optometrist every twenty-four (24) consecutive months.
  - Orthotics & orthopedic shoes maximum of one (1) pair ~~\$400~~ **\$500** per calendar year.
  - Pharmacy dispensing fees capped at ~~\$10.00~~ and increase to **\$11.00** effective ~~February 1, 2013~~. No O.T.C. drug coverage with the exception of those deemed by the insurer to be "life sustaining".
- Paramedical Benefit:
  - Maximum of ~~\$1,400~~ **\$1500.00** per calendar year for any combination of the following services:  
  
Physiotherapist, ~~Clinical Psychologist or Marriage & Family Therapist~~, Massage Therapist, Speech Pathologist, Chiropractor, Osteopath, Podiatrist, Chiropodist, Naturopath, and Nutritional Counselling by Professional Dietician.
- Maximum of ~~\$1000~~ **\$1500** per calendar year for Psychological Benefit (MSW, Registered Counsellor, Psychologist **or Marriage & Family Therapist**).
- Out of Province Travel Plan
- Dental Plan #9, with Rider #3 (Orthodontic, three thousand **five hundred dollars** (~~\$3,000~~ **\$3500** limit), at current ODA rates minus one year.
- Overage Dependent Coverage is applied to the Green Shield Extended Health Care and the Dental Plan, 100% of the cost to be paid for by the

2023 – Local 67 Civic Centre

Final Offer

Page 7 of 11

City. It is agreed that the full U.I.C. rebate on premiums shall be retained by the City.

Coverage for new employees shall be effective as follows:

- (a) Extended Health Care – 1<sup>st</sup> day the month following date employed.
- (b) Dental – 1<sup>st</sup> day of the month following completion of three (3) months service.

**12 Month Pregnancy/Parental Replacement Temporary Employees – Limited Benefit Coverage**

- Prescription Drug Benefit Plan at 90%/10% Co-Insurance (Plan subject to elimination of OTC's and \$811 Dispensing Fee Cap. And effective February 1, 2014 increase to \$10
- Vision Care – \$125 (effective 1<sup>st</sup> of the month following ratification) amount effective February 1, 2023 \$475 and increasing to \$500 effective February 1, 2024 per 24 months.

**23:00 Wage Schedule**

**To be applied to Schedule of Progressional Rates**

**2023 – 3.50%**

**2024 – 3.00%**

**2025 – 3.00%**

**2026 – 3.00%**

**2027 – 3.75%**

**27:00 TERM OF AGREEMENT**

**CURRENT LANGUAGE**

27:01 This agreement shall continue in force and effect from February 1<sup>st</sup>, 2019 to January 31<sup>st</sup>, 2023. Either party to this Agreement may, not more than ninety (90) days, and not less than thirty (30) days prior to January 31<sup>st</sup>, 2023 present to the other party in writing proposed terms of a new or further Agreement and/or Amendments to this Agreement and a conference shall be held within fifteen (15) days at which time the parties will commence negotiations on the proposed amendments and/or the terms of a new Agreement. Failing agreement by

January 31<sup>st</sup>, 2023, this Agreement and all its terms will continue in force until a new Agreement is executed.

**PROPOSED LANGUAGE**

27:01 This agreement shall continue in force and effect from ~~February 1<sup>st</sup>, 2019 until January 31<sup>st</sup>, 2023~~ **February 1, 2023 until January 31<sup>st</sup>, 2028**. Either party to this Agreement may, not more than ninety (90) days, and not less than thirty (30) days prior to January 31<sup>st</sup>, ~~2023~~ **2028** present to the other party in writing proposed terms of a new or further Agreement and/or Amendments to this Agreement and a conference shall be held within fifteen (15) days at which time the parties will commence negotiations on the proposed amendments and/or the terms of a new Agreement. Failing agreement by January 31<sup>st</sup>, ~~2023~~ **2028**, this Agreement and all its terms will continue in force until a new Agreement is executed.

**Letter of Understanding**

**Between**

**The Corporation of the City of Sault Ste. Marie (employer)**

**And**

**C.U.P.E. Local 67 (union)**

C.U.P.E. Local 67 (“CUPE”) and the Corporation of the City of Sault Ste. Marie (“the City”) entered into negotiations to amend the collective agreement in January of 2023. The union submitted a proposal under Article 15 – Regular Hours of Work and Working Conditions for new language pertaining to a compressed work week cycle. This involved varying the standard five (5) day work week into fewer but longer days to facilitate additional time off. The City, in response, countered with an offer to include this letter of understanding into the Minutes of Settlement to demonstrate our commitment to implementing a pilot project.

**Whereas** the employer has the right to set the working conditions, location and scheduled hours of work and;

**Whereas** the employer will consider the union proposal as an upcoming pilot project among the employees of Local 67 and management;

The parties agree on a without prejudice or precedent basis to the following:



1. Within one (1) month of full ratification of the collective agreement, the City will strike a committee consisting of both management and union representation from each functional area.
2. The Committee's purpose will be to provide input on the scope, terms and conditions of a potential compressed work week and/or hybrid schedule and the impact on their functional area(s);
3. Management solely retains the right to set conditions of work and will review both union and non-union positions within the organization to establish those which are operationally eligible for a compressed schedule and/or hybrid remote work schedule;
4. Human Resources would then develop an operating proposal and corporate policy to frame the purpose, scope terms and conditions for consideration by the Senior Management Team;
5. It is understood that Remote Team Leadership / Management Training will need to occur prior to implementation. Human Resources will arrange for the provision of any necessary training for Supervisors and Managers;
6. Management will develop an IT and communications strategy for employees and stakeholders;
7. If approved by the Senior Management Team, the City would enter into a one (1) year pilot project to test the new schedule(s), with the option to amend and/or extend as necessary.

Dated this 15<sup>th</sup> day of June, 2023.

For the City:

*John Bruno*

*Wade Ottoluno*

*P. Iggo*

*Shelley Scheel*

*[Signature]*

For the Union:

*Harold S. Pease*

*Michelle Quinton*

*Kevin Lavergne*

*[Signature]*

SIGNED AT SAULT STE. MARIE this 18<sup>th</sup> day of June, 2023

FOR C.U.P.E LOCAL 67

Sharon L. Pierce

Michelle Quinton

Kevin Favre

[Signature]

FOR CITY

Joe Bruno

Mark Ottolino

P. Szwajko

Sherry Shell

[Signature]

[Signature]

RENEW

LETTER #1

LETTER OF UNDERSTANDING

Between

THE CITY OF SAULT STE. MARIE

and

LOCAL 67 C.U.P.E.

The parties agree in principle to the following amendment to this clause:

Article 19:08

An employee absent on W.S.I.B. shall receive a further payment, in addition to any W.S.I.B. payments that will provide a total payment to the employee that will approximate but not exceed such employee's net pay.

It is agreed that this amendment is subject to a review of the actual method of calculation, the matter will be finalized by letter of agreement.

Signed at Sault Ste. Marie this 1<sup>st</sup> day of June, 2023.

FOR C.U.P.E LOCAL 67

Harvey St. Pierre  
Michelle Lacroix  
Karin Lavigne  
\_\_\_\_\_

FOR CITY

John Brun  
Walter Holm  
P. Scypio  
Reilly Sheel  
CS  
Justin Talbot

RENEW

LETTER #2

LETTER OF UNDERSTANDING

Between

THE CITY OF SAULT STE. MARIE

and

LOCAL 67 C.U.P.E.

The parties agree that this letter of understanding shall serve as a guideline for the application of Article 11:02 in matters of decreases in forces and recalls to former positions.

It is agreed that in the application of seniority and qualifications, that in normal circumstances the incumbent in the higher job classes, i.e. Job Class 7 and above, will be presumed to have the greater qualifications to perform the work, except if the senior employee has previously performed the work and established the ability to do the job.

In the displacement of employees in lower job classes, due consideration will be given to the skill level and the period of familiarization and due regard to any special skills required to perform the job.

The foregoing is not intended as an abrogation of any rights contained within the collective agreement.

Signed at Sault Ste. Marie this 15<sup>th</sup> day of June, 2023.

FOR C.U.P.E LOCAL 67

[Signature]  
[Signature]  
[Signature]  
[Signature]

FOR CITY

[Signature]  
[Signature]  
[Signature]  
[Signature]  
[Signature]

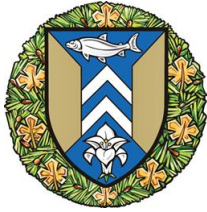

The Corporation of the  
City of Sault Ste. Marie  
**COUNCIL REPORT**

June 19, 2023

**TO:** Mayor Matthew Shoemaker and Members of City Council  
**AUTHOR:** Ida Bruno, Labour Relations Coordinator  
**DEPARTMENT:** Corporate Services  
**RE:** Memorandum of Settlement for Amalgamated Transit Union (ATU) Local 1767

- Formatted: Font: Not Bold
- Formatted: Font: Not Bold
- Formatted: Font: Not Bold
- Formatted: Font: Not Bold
- Formatted: Font: Not Bold
- Formatted: Font: Not Bold
- Formatted: Font: Not Bold
- Formatted: Font: Not Bold
- Formatted: Font: Not Bold
- Formatted: Font: Not Bold

**PURPOSE**

The purpose of this report is to recommend the approval of the attached Memorandum of Settlement for ATU Local 1767 (Transit Operators).

**BACKGROUND**

The City, through the collective bargaining process, has reached a Memorandum of Settlement with the aforementioned unionized group for a four (4) year term.

**ANALYSIS**

The highlights of the settlement are as follows:

***Amalgamated Transit Union Local 1767***

- Average annual increase to budget of 3.48% (inclusive of wage and benefit increases)
- Benefit enhancements including increased life insurance, Maple Virtual Health Care Service and a combined paramedical services account.
- Increase to Short Term Disability Plan income replacement (60% to 70% of weekly gross earnings)
- EAP Benefit provider change to Inkblot
- Improvements to contract language and introduction of a lieu time bank.
- Improvements to hours of work

**FINANCIAL IMPLICATIONS**

The financial impact of these settlements for 2023 can be accommodated in the contingency reserve provided for that purpose in the 2023 Budget. Future years' impacts will be outlined in the budget deliberations for those years. Please note:

- The lieu time bank can offset some overtime being paid out when we are at full complement.

Memorandum of Settlement for Amalgamated Transit Union (ATU) Local 1767  
June 19, 2023  
Page 2.

Formatted: Space After: 0 pt

- Uniforms will be distributed every second year as opposed to every year beginning after 2024.
- The pay rate effective date of January 1<sup>st</sup> was negotiated for 2024 only.
- 

Formatted: Bulleted + Level: 1 + Aligned at: 0.29" + Indent at: 0.54"

### STRATEGIC PLAN / POLICY IMPACT

This item applies to the Service Delivery focus area of the Corporate Strategic Plan.

### RECOMMENDATION

It is therefore recommended that Council take the following action:

Resolved that the report of the Labour Relations Coordinator dated June 19, 2023 concerning Memorandum of Settlement for Amalgamated Transit Union (ATU) Local 1767 be received and ~~approve~~ that Council ratify the Memorandum of Settlement ~~for Amalgamated Transit Union Local 1767 be ratified~~.

Formatted: Indent: Left: 0"

Respectfully submitted,

Ida Bruno, CHRL  
Labour Relations Coordinator  
705.759.5449  
[i.bruno@cityssm.on.ca](mailto:i.bruno@cityssm.on.ca)

MEMORANDUM OF SETTLEMENT

THE CORPORATION OF THE CITY OF SAULT STE. MARIE  
&  
ATU LOCAL 1767

1. The parties herein agree to the terms of the memorandum as constituting full and final settlement of all matters in dispute.
2. The undersigned representatives of the parties do hereby agree to recommend complete acceptance of all the terms of this memorandum to their respective principals.
3. The parties herein agree that the term of the collective agreement shall be from February 1, 2023 to January 31, 2027.
4. Retroactivity will only apply to the Wage Schedule. All other terms negotiated will be in effect the 1<sup>st</sup> of the following month after ratification by both parties.
5. The parties herein agree that the said collective agreement shall include the terms of the previous collective agreement which expired on January 31, 2023 provided, however, that the following amendments are incorporated in Appendix 1.

Signed this 8<sup>th</sup> day of June, 2023.

For the Union

  
\_\_\_\_\_  
Brent Cerenzia

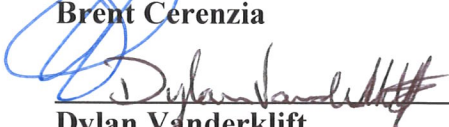
  
\_\_\_\_\_  
Dylan Vanderklift

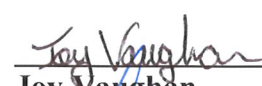
  
\_\_\_\_\_  
Joy Vaughan

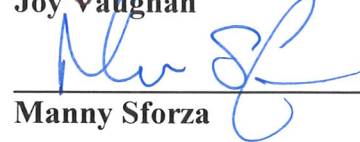
  
\_\_\_\_\_  
Manny Sforza

For the Employer

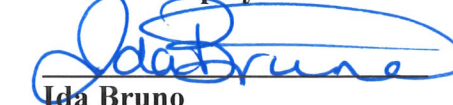
  
\_\_\_\_\_  
Ida Bruno

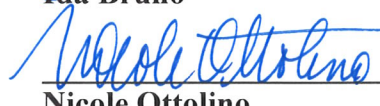
  
\_\_\_\_\_  
Nicole Ottolino

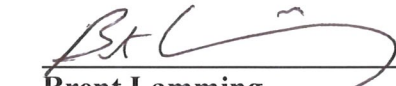
  
\_\_\_\_\_  
Brent Lamming

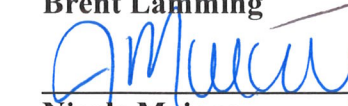
  
\_\_\_\_\_  
Nicole Maione

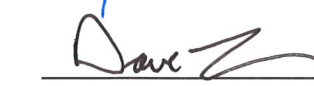
  
\_\_\_\_\_  
Dave Lamming

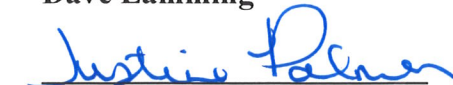
  
\_\_\_\_\_  
Justine Palmer

# Appendix 1



Sign Off Sheet #1

ATU Local 1767

&

The City of Sault Ste. Marie

**General “Housekeeping” Changes**

- Change all references of ‘him’ or ‘her’ to gender neutral terminology (e.g. ‘their’)

**ORIGINAL ARTICLE**

5:07 The parties agree to establish a Joint Consultation Committee with equal representation from each party to deal with matters of mutual concern relating to the workplace. The terms and conditions of such Committee will be established by the parties.

**PROPOSED ARTICLE**

5:07 The parties agree to establish a Joint Consultation / **Labour Management Committee** with equal **three union representatives** representation from each party to deal with matters of mutual concern relating to the workplace. The terms and conditions of such Committee will be established by the parties.

**ORIGINAL ARTICLE**

**ARTICLE 7:00 GRIEVANCE PROCEDURE**

7:01 Should a dispute arise between the City and any employee(s) regarding the interpretation, meaning, operation or application of the terms of the Agreement including any questions as to whether a matter is arbitratable or where an allegation is made that the Agreement has been violated, an earnest effort shall be made to settle the dispute in the following manner providing such grievance is established within 15 calendar days of the occurrence of the facts or events which gave rise to the matter in dispute. Requests for grievance hearings and replies following such hearings shall be in writing at all steps.

**COMPLAINT**

Grievances shall first be dealt with as a complaint.

It is understood that there is no grievance until the Manager of Transit Services or representative has first had the opportunity to adjust the complaint. Any resolution to

a complaint at this step is understood to be without precedent or prejudice to either party.

STEP I The employee, who may be assisted by a representative of the Union, shall discuss the grievance with the Director of Community Services and Enterprise Development. A representative from Human Resources may also attend. Such discussion shall take place within ten (10) days of receipt of the grievance. The Director of Community Services and Enterprise Development shall render their decision within five (5) calendar days of the hearing.

STEP II If the Union considers that a satisfactory settlement was not reached at Step I, it may, within ten (10) calendar days of receipt of the reply at Step I, request a hearing by the Director of Human Resources, or the designate. Such hearing will be held within fifteen (15) days of the request. The request will state the reason or reasons the answer at Step I was unsatisfactory and in what manner the City's interpretation of the contract clause is disputed. The Director of Human or their representative shall render a decision within five (5) calendar days of the hearing.

STEP III If the Union considers that a satisfactory settlement was not reached at Step II, it may within ten (10) calendar days of receipt of the reply at Step II, request a hearing by the Deputy Chief Administrative Officer of CDES, or the designate. Such requests shall state the reason or reasons the answer at Step II was unsatisfactory and in what manner the City's interpretation of the contract clause in question is disputed. The Deputy Chief Administrative Officer of CDES or the designate shall render a decision within five (5) calendar days of the hearing.

The parties when required may agree to utilize mediation services prior to arbitration. At no time shall this article be applied or interpreted as a necessary step before arbitration.

STEP IV If the Union considers that a satisfactory settlement was not reached at Step III, it may, within ten (10) calendar days of receipt of the Step III reply, request a hearing by the Chief Administrative Officer. Following this meeting the Chief Administrative Officer shall render a decision within ten (10) calendar days of the hearing.

#### ARBITRATION

If the Union considers that a satisfactory settlement was not reached at Step IV of the Grievance Procedure, it may, within ten (10) calendar days of receipt of the Step IV reply, request that the grievance be referred to arbitration in accordance with the Labour Relations Act of Ontario. A Board of Arbitrators shall not alter, modify or amend any part of the Agreement or make any decision inconsistent with its provisions. However, the Board shall have the power to dispose of a discharge or discipline grievance in a manner which in its opinion, it deems just and equitable. The decision of the Board may be made retroactive to the day when the employee first placed the question before the City by filing of a written grievance.

Each of the parties hereto will bear the expense of its appointed Nominee to the Board of Arbitration and the parties will jointly bear the expense of the Chair of the Arbitration Board.

The time limits fixed in the Arbitration Procedure must be observed unless extended by mutual agreement of the parties.

## PROPOSED ARTICLE

### ARTICLE 7:00 GRIEVANCE PROCEDURE

7:01 Should a dispute arise between the City and any employee(s) regarding the interpretation, meaning, operation or application of the terms of the Agreement including any questions as to whether a matter is **able to be arbitrated** arbitratable or where an allegation is made that the Agreement has been violated, an earnest effort shall be made to settle the dispute in the following manner providing such grievance is established within 15 calendar days of the occurrence of the facts or events which gave rise to the matter in dispute. Requests for grievance hearings and replies following such hearings shall be in writing at all steps.

### COMPLAINT

Grievances shall first be dealt with as a complaint.

It is understood that there is no grievance until the Manager of Transit Services or representative has first had the opportunity to adjust the complaint. Any resolution to a complaint at this step is understood to be without precedent or prejudice to either party.

STEP I The employee, who may be assisted by a representative of the Union, shall discuss the grievance with the Director of Community Services and Enterprise Development. A representative from Human Resources may also attend. Such discussion shall take place within

ten (10) **business** days of receipt of the grievance. The Director of Community Services and Enterprise Development shall render their decision within five (5) calendar **business** days of the hearing.

STEP II If the Union considers that a satisfactory settlement was not reached at Step I, it may, within ten (10) calendar **business** days of receipt of the reply at Step I, request a hearing by the Director of Human Resources, or the designate. Such hearing will be held within fifteen (15) **business** days of the request. The request will state the reason or reasons the answer at Step I was unsatisfactory and in what manner the City's interpretation of the contract clause is disputed. The Director of Human or their representative shall render a decision within five (5) calendar **business** days of the hearing.

STEP III If the Union considers that a satisfactory settlement was not reached at Step II, it may within ten (10) calendar **business** days of receipt of the reply at Step II, request a hearing by the Deputy Chief Administrative Officer of CDES, or the designate. Such requests shall state the reason or reasons the answer at Step II was unsatisfactory and in what manner the City's interpretation of the contract clause in question is disputed. The Deputy Chief Administrative Officer of CDES or the designate shall render a decision within five (5) calendar **business** days of the hearing.

The parties when required may agree to utilize mediation services prior to arbitration. At no time shall this article be applied or interpreted as a necessary step before arbitration.

STEP IV If the Union considers that a satisfactory settlement was not reached at Step III, it may, within ten (10) **business** calendar days of receipt of the Step III reply, request a hearing by the Chief Administrative Officer. Following this meeting the Chief Administrative Officer shall render a decision within ten (10) calendar **business** days of the hearing.

## ARBITRATION

If the Union considers that a satisfactory settlement was not reached at Step IV of the Grievance Procedure, it may, within ten (10) calendar **business** days of receipt of the Step IV reply, request that the grievance be referred to arbitration in accordance with the Labour Relations Act of Ontario. A Board of Arbitrators shall not alter, modify or amend any part of the Agreement or make any decision inconsistent with its

provisions. However, the Board shall have the power to dispose of a discharge or discipline grievance in a manner which in its opinion, it deems just and equitable. The decision of the Board may be made retroactive to the day when the employee first placed the question before the City by filing of a written grievance.

Each of the parties hereto will bear the expense of its appointed Nominee to the Board of Arbitration and the parties will jointly bear the expense of the Chair of the Arbitration Board.

The time limits fixed in the Arbitration Procedure must be observed unless extended by mutual agreement of the parties.

**ORIGINAL ARTICLE:**

**ARTICLE 16:00 PENSIONS**

16:01 All employees covered by this Agreement will participate in the Ontario Municipal Employees Retirement System and the Canada Pension Plan in accordance with the applicable statutes. Employees may become eligible for OMERS enrolment based on the following conditions provided they do not contravene the OMERS regulations:

1. An employee will be offered enrollment when the employee is considered "Other Than Continuous Full Time" as defined by OMERS if they work 700 hours in each of two (2) consecutive years in the third year commencing employment.
2. Upon picking a regular posted assignment ("Picked Run") as per Article 9:01 (a) such employee shall be enrolled in OMERS as Continuous Full Time. Upon completion of the posted assignment if the operator returns to Spareboard
3. Such employee will remain enrolled as Other Than Continuous Full Time.

**PROPOSED ARTICLE:**

**ARTICLE 16:00 PENSIONS**

16:01 All employees covered by this Agreement will participate in the Ontario Municipal Employees Retirement System and the Canada Pension Plan in accordance with the applicable statutes **and regulations**. ~~Employees may become eligible for OMERS~~

enrolment based on the following conditions provided they do not contravene the OMERS regulations:

1. An employee will be offered enrollment when the employee is considered "Other Than Continuous Full Time" as defined by OMERS
2. if they work 700 hours in each of two (2) consecutive years in the third year commencing employment.
3. Upon picking a regular posted assignment ("Picked Run") as per Article 9:01 (a) such employee shall be enrolled in OMERS as Continuous Full Time. Upon completion of the posted assignment if the operator returns to Spareboard
4. Such employee will remain enrolled as Other Than Continuous Full Time.

SIGNED AT SAULT STE. MARIE this 22<sup>nd</sup> day of March, 2023

FOR ATU LOCAL 1767

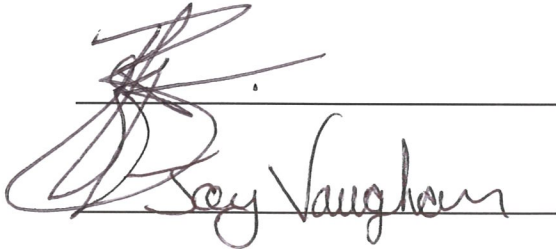
  
\_\_\_\_\_  
Roy Vaughan

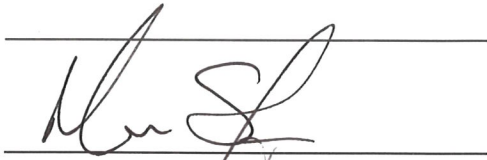
  
\_\_\_\_\_  
\_\_\_\_\_

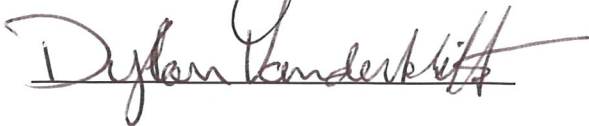
  
\_\_\_\_\_  
Dylan Vanderkift

FOR CITY

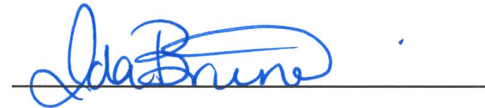
  
\_\_\_\_\_  
Ida Bruno

  
\_\_\_\_\_  
Dave

  
\_\_\_\_\_  
Nicole Ottolino

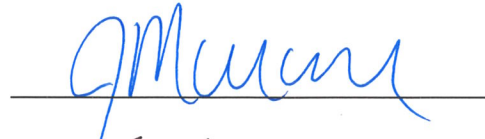
  
\_\_\_\_\_  
M. Murray

  
\_\_\_\_\_  
\_\_\_\_\_

Sign Off Sheet #2

ATU Local 1767

&

The City of Sault Ste. Marie

**ORIGINAL ARTICLE:**

5:03 The Union further recognizes the right of the City to make or alter rules and regulations from time to time which in the City's discretion are deemed necessary for the safe, continuous, effective, and efficient, operation of the services. The City will advise the Union Representatives of such rules and regulations, or changes to rules and regulations, prior to the implementation of such rules or regulations. No such rule or regulation shall be inconsistent with the terms of this agreement.

**PROPOSED ARTICLE:**

5:03 The Union further recognizes the right of the City to make or alter rules and regulations from time to time which in the City's discretion are deemed necessary for the safe, continuous, effective, and efficient, operation of the services. The City will advise the Union Representatives of such rules and regulations, or changes to rules and regulations, prior to the implementation of such rules or regulations. Notice will be given thirty (30) days in advance, where possible. No such rule or regulation shall be inconsistent with the terms of this agreement.

**Move 9:01 (b) to 11:08**

9:01 (b) Operators scheduled to work greater than five (5) consecutive hours will be provided a thirty (30) minute paid lunch period.

**ORIGINAL ARTICLE**

**ARTICLE 9:00 SENIORITY**

9:01

- (a) Seniority rights of Operators will be exercised only as provided in this Agreement.

The right to pick a regular posted assignment shall be governed by seniority. Where such assignments have two complete shifts, the Operators assigned to such assignments shall alternate shifts a week about. Regular assignments, as designated by the Employer, shall be runs which require approximately a standard work week of not less than forty (40) hours. An employee performing a regular assignment shall have their pay reduced by any part of the assignment not performed by the employee.

Any route changes that affect run duration will be deferred until the next formal pick.

Operators shall make their choice of assignments according to seniority. Such assignments are to take effect the first Sunday which starts a pay period in the months of March, June, September and December. Operators will select such assignments during the third week prior to the effective date of the pick. Operators will make their picks by seniority as follows:

Tuesday – Operators	1 - 12
Wednesday – Operators	13 - 24
Thursday – Operators	25 - 36
Friday – Operators	37 - 48
Saturday – Operators	49 - 60
Sunday – Operators	61 - end

Pick periods will be scheduled at 40 minute time intervals until 4:00 P.M. of the pick day. If an Operator fails to pick an assignment as scheduled, such Operator will be assigned to the spareboard. If an Operator is off sick or on compensation at the time of the pick, the Operator shall present proof at the designated pick time, by a medical practitioner that the Operator will be able to return to work within 30 days of posting of the pick in order to exercise the Operator's pick privileges. If the Operator fails to return to work within 30 days of the Operator's designated pick time, upon the Operator's return, the Operator will be assigned to the spareboard for the duration of the pick.

Regular assigned Operators will be allowed to forfeit without pay, a two and a half (2.5) hour work assignment when that assignment is their only



assigned work for that day. Upon picking their run assignment, they will sign a form stating that they do not wish to work the assignment in question for the duration of the pick.

- (b) Operators scheduled to work greater than five (5) consecutive hours will be provided a thirty (30) minute paid lunch period.

**PROPOSED ARTICLE**

**ARTICLE 9:00 SENIORITY**

9:01

- (a) Seniority rights of Operators will be exercised only as provided in this Agreement.

The right to pick a regular posted assignment shall be governed by seniority. ~~Where such assignments have two complete shifts, the Operators assigned to such assignments shall alternate shifts, a week about.~~ Regular assignments, as designated by the Employer, shall be runs which require approximately a standard work week of not less than forty (40) hours. An employee performing a regular assignment shall have their pay reduced by any part of the assignment not performed by the employee.

Any route changes that affect run duration will be deferred until the next formal pick.

Operators shall make their choice of assignments according to seniority. **It is the sole responsibility of the Operator to know their pick time.** Such assignments are to take effect the first Sunday which starts a pay period in the months of March, June, September, and December. Operators will select such assignments during the third week prior to the effective date of the pick. Operators will make their picks by seniority as follows:

Tuesday – Operators	1 - 12
Wednesday – Operators	13 - 24
Thursday - Operators	25 - 36
Friday - Operators	37 - 48
Saturday - Operators	49 - 60
Sunday - Operators	61 - end

Pick periods will be scheduled at 40 minute time intervals until 4:00 P.M. of the pick day. If an Operator fails to pick an assignment as scheduled, such Operator will be assigned to the spareboard. If an Operator is off sick **or in receipt of WSIB benefits** ~~on compensation~~ at the time of the pick, the Operator shall present proof at the designated pick time, by a medical practitioner that the Operator will be able to return to work **full duties** within 30 days of ~~posting~~ **start** of the pick in order to exercise the Operator's pick privileges. If the Operator fails to return to work within 30 days of the Operator's designated pick time, upon the Operator's return, the Operator will be assigned to the spareboard for the duration of the pick.

Regular assigned Operators will be allowed to forfeit without pay, a two and a half (2.5) hour work assignment when that assignment is their only assigned work for that day. Upon picking their run assignment, they will sign a form stating that they do not wish to work the assignment in question for the duration of the pick.

~~(b) Operators scheduled to work greater than five (5) consecutive hours will be provided a thirty (30) minute paid lunch period.~~

## ORIGINAL ARTICLE

9:03 Seniority is an exclusive right and under the jurisdiction of Local 1767 of the ATU. All employees shall hold their seniority in accordance with their continuous employment with the Corporation of the City of Sault Ste. Marie Transit Services.

Top 3 Spareboard Operators (not on Sick Leave or WSIB) may choose to start their work week on Monday. Their choice will be in effect for the duration of the pick. If a Relief Inspector occupies one of these positions, it will be passed down to the next senior Spareboard Operator. Relief Inspector's days off will be assigned at the discretion of the Scheduler.

When Spareboard Operators are required, the senior operator in point of service will be called for duty, and will be paid a minimum of two (2) hours. The employee will be paid for all time worked, computed on the closest 5 minute basis. Where practical, and where no added costs to the Employer are incurred, rest days will be assigned in consecutive pairs.

An Inspector will be allowed to cover emergency work until an Operator reports for duty.

When an Operator who is on a regular picked run is called out from home to report for work within the hour, the employee will be paid a 4 hour minimum call out. Such call out hours will not be used in the calculation of overtime under Article 11:00.

9:04 When a spare Operator is called and not available for work, the next in point of service will be called and so on until the vacancy for a spare Operator is filled. Spare Operators who have been called and are not available shall lose their turn.

9:05 The City will select the Operators to be sent on charter trips outside the City limits.

9:06 When forces are reduced, Operators shall be taken off in the reverse order of seniority and will retain all rights and privileges. Operators furloughed on account of reduction in forces will be privileged to work elsewhere and retain their seniority. They must maintain on record with the City their correct address and renew same every thirty (30) days. Operators will be called back to service in seniority order according to the following procedure.

The City will advise each Operator to be recalled by registered mail or telegram.

A copy of such recall notice will be furnished to the Union representative. An Operator receiving such notice will acknowledge receipt of same by registered mail or telegram within seven (7) days, advising the City that the employee will be available for service, which date must not be later than fifteen (15) days from the date the City forwarded recall notices. In extenuating circumstances the fifteen (15) day time limit may be extended at the discretion of the Manager of Transit & Parking. Furloughed Operators failing to comply with these regulations will forfeit their seniority rights and be considered as out of service.

## **PROPOSED ARTICLE**

9:03 Seniority is an exclusive right and under the jurisdiction of Local 1767 of the ATU. All employees shall hold their seniority in accordance with their continuous employment with the Corporation of the City of Sault Ste. Marie Transit Services.

Top 3 Spareboard Operators (not on Sick Leave or WSIB) may choose to start their work week on Monday. Their choice will be in effect for the duration of the pick. If a Relief Inspector occupies one of these positions, it will be passed down to the next senior Spareboard Operator. Relief Inspector's days off will be assigned at the discretion of the Scheduler.

When Spareboard Operators are required, the senior operator in point of service will be called for duty, and will be paid a minimum of two (2) hours. The employee will be paid for all time worked, computed on the closest 5 minute basis. Where practical, and where no added costs to the Employer are incurred, rest days will be assigned in consecutive pairs.

An Inspector **and/or Supervisor** will be allowed to cover emergency work until an Operator reports for duty.

When an Operator who is on a regular picked run is called out from home to report for work within the hour, the employee will be paid a 4 hour minimum call out. Such call out hours will not be used in the calculation of overtime under Article 11:00.

9:04 When a spare Operator is called and not available for work, the next in point of service will be called and so on until the vacancy for a spare Operator is filled. Spare Operators who have been called and are not available shall lose their turn. **All calls will be placed by phone or over the radio if the Operator is currently working. The calls will be made as per the call out list.**

9:05 The City will select the Operators to be sent on charter trips outside the City limits.

9:06 When forces are reduced, Operators shall be taken off in the reverse order of seniority and will retain all rights and privileges. Operators furloughed on account of reduction in forces will be privileged to work elsewhere and retain their seniority. They must maintain on record with the City their correct address and renew same every thirty (30) days. Operators will be called back to service in seniority order according to the following procedure.

The City will advise each Operator to be recalled by registered mail or telegram: **email**.

A copy of such recall notice will be furnished to the Union representative. An Operator receiving such notice will acknowledge receipt of same by registered mail or **email** telegram within seven (7) days, advising the City that the employee will be available for service, which date must not be later than fifteen (15) days from the date the City forwarded recall notices. In extenuating circumstances the fifteen (15) day time limit may be extended at the discretion of the Manager of Transit & Parking. Furloughed Operators failing to comply with these regulations will forfeit their seniority rights and be considered as out of service.

**Moved from 10:05 to New 9:08 f)** Any Operator having been absent in excess of five (5) days in succession, ~~thereby forfeits all rights with the City~~ except in the case of sickness, or when leave of absence has been granted. No leave of absence shall be extended to exceed six (6) months, nor reinstatement made after six (6) months continuous absence, except in case of sickness ~~or on active service during war period.~~

**ORIGINAL ARTICLE:**

10:04 The City may grant, in writing, a leave of absence without loss of seniority and without pay for a period of up to 6 months to any Operators requesting such leave in writing for a good and sufficient cause. For leaves of absences greater than 6 months, the Letter of Understanding dated March 2, 1988, shall apply.

**PROPOSED ARTICLE:**

10:04 The City may grant, in writing, a leave of absence without loss of seniority and without pay for a period of up to 6 months to any Operators requesting such leave in writing for a good and sufficient cause. ~~For leaves of absences greater than 6 months, the Letter of Understanding dated March 2, 1988, shall apply.~~

**ORIGINAL ARTICLE**

10:05 Any Operator having been absent in excess of five (5) days in succession, thereby forfeits all rights with the City except in the case of sickness, or when leave of absence has been granted. No leave of absence shall be extended to exceed six (6) months, nor reinstatement made after six (6) months continuous absence, except in case of sickness or on active service during war period.

10:06 When death occurs to a member of an employee's immediate family, the employee will be granted leave of absence on compassionate grounds and will be granted time off with pay up to a maximum of four (4) working days for any days which are normally straight time working days and fall within the period from the day of the death up to and including the day following the funeral. If the funeral is more than two hundred kilometers (200 km) from Sault Ste. Marie, the four (4) working days shall be any days which are normally straight time working days and fall within the period from the day of the death up to and including the day following the funeral.

Immediate family means: mother, father, sister, brother, spouse, common-law spouse, son, daughter, grandchildren, grandparents, mother-in-law, father-in-law, step-parents, step-siblings. Leave of absence without loss of pay for four working days shall be granted to an employee to attend the funeral of a child of a spouse as defined under part (b) sections (i) and (iii) below.

Leave of absence without loss of pay for one (1) day shall be granted to an employee to attend the funeral of the employee's son-in-law, daughter-in-law, brother-in-law,

sister-in-law, aunt and uncle. Non attendance at the funeral regardless of distance disqualifies the employee from funeral leave.

“Spouse” means a person

- (a) to whom a person is married, or
- (b) with whom the person is living outside marriage in a conjugal relationship, if the two persons,
  - (i) have cohabited for at least one year
  - (ii) are together the parents of a child, or
  - (iii) have together entered into a cohabitation agreement under section 53 of the *Family Law Act*: (“conjont”)

## **PROPOSED ARTICLE**

### **Move to 9:08 (f)**

~~10:05 Any Operator hasving been absent in excess of five (5) days in succession, thereby forfeits all rights with the City except in the case of sickness, or when leave of absence has been granted. No leave of absence shall be extended to exceed six (6) months, nor reinstatement made after six (6) months continuous absence, except in case of sickness or on active service during war period.~~

10:06 When death occurs to a member of an employee’s immediate family, the employee will be granted leave of absence on compassionate grounds and will be granted time off with pay up to a maximum of four (4) working days for any days which are normally straight time working days and fall within the period from the day of the death up to and including the day following the funeral. ~~If the funeral is more than two hundred kilometers (200 km) from Sault Ste. Marie, the four (4) working days shall be any days which are normally straight time working days and fall within the period from the day of the death up to and including the day following the funeral.~~

Immediate family means: mother, father, sister, brother, spouse, common-law spouse, son, daughter, grandchildren, grandparents, mother-in-law, father-in-law, step-parents, step-siblings. Leave of absence without loss of pay for four working days shall be granted to an employee to attend the funeral of a child of a spouse as defined under part (b) sections (i) and (iii) below.

Leave of absence without loss of pay for one (1) day shall be granted to an employee to attend the funeral of the employee's son-in-law, daughter-in-law, brother-in-law, sister-

in-law, aunt and uncle. ~~Non-attendance at the funeral regardless of distance disqualifies the employee from funeral leave.~~

“Spouse” means a person

- (a) to whom a person is married, or
- (b) with whom the person is living outside marriage in a conjugal relationship, if the two persons,
  - (i) have cohabited for at least one year
  - (ii) are together the parents of a child, or
  - (iii) have together entered into a cohabitation agreement under section 53 of the *Family Law Act*: (“conjoint”)

**ORIGINAL ARTICLE:**

12:03 The City agrees to make payroll deductions for employees making contributions to the Northern Credit Union.

**PROPOSED ARTICLE:**

~~12:03 The City agrees to make payroll deductions for employees making contributions to the Northern Credit Union.~~

**ARTICLE 15:00 WELFARE**

15:01 The City agrees to provide the following welfare benefits to employees classified as Operator II with the City paying 100% of the premiums for such benefits:

Ontario Health Insurance Plan

Life Insurance plus A.D. & D. \$38,000.00

Weekly Accident and Sickness Benefit – Effective January 1, 2016:

The amount of the Weekly Accident and Sickness Benefit shall be sixty percent (60%) of basic weekly earnings. It is understood and agreed by the parties that in return for this benefit the full U.I.C. rebate

on premiums shall be retained by the City.

Green Shield Extended Healthcare Benefit

Benefit changes effective the first of the month following ratification of the Memorandum of Settlement by the parties:

- \$9.00 drug card system (drug plan is voluntary generic substitution).
- Vision Care (eyeglass subsidy \$450.00 every two years). Amount of Vision Care can be used for Eye Vision Lasik Surgery or contact lenses.
- One (1) eye examination by a licensed ophthalmologist or optometrist every twenty-four (24) consecutive months or when the Ministry of Transportation requests a complete physical including eye examination for the employee's drivers' licence.
- Pharmacy dispensing fees capped at \$10 per prescription. No O.T.C. drug coverage with the exception of those deemed by the insurer to be "life sustaining".
- Orthotics – 50% / 50% co-share.
- Orthodontic - \$2500.00 (effective Feb. 1, 2018)

Cap Private Duty Nursing @ ninety (90) – eight (8) hour shifts per year.

Long Term Disability to provide 60% of an employee's basic hourly rate after 26 weeks with Canada Pension Plan as a primary offset.

Coverages for Group Life Insurance and Long Term Disability Insurance shall normally be adjusted effective on the first day of February following, but adjustments arising from the terms of a new or revised agreement shall be made effective as soon as possible after the signing of the terms of the settlement. Coverage shall be in



accordance with the terms and conditions of Great West Life Policy #320925 Division 9.

The inclusion of the policy number is for identification only and will not affect other articles of the Collective Agreement.

- **Active Employees Over Age 65**

Active employees over age 65 will enjoy the same benefits as active under age 65, except for LTD and AD&D, which will terminate on the day the employee attains age 65. Life Insurance: Reduce to \$10,000 fixed to retirement or age 70 max.

## **ARTICLE 15:00 WELFARE**

15:01 The City agrees to provide the following welfare benefits to employees classified as Operator II with the City paying 100% of the premiums for such benefits:

Ontario Health Insurance Plan

Life Insurance plus A.D. & D. \$38,000.00

Weekly Accident and Sickness Benefit – Effective January 1, 2016:

The amount of the Weekly Accident and Sickness Benefit shall be sixty percent (60%) of basic weekly earnings. It is understood and agreed by the parties that in return for this benefit the full U.I.C. rebate

on premiums shall be retained by the City.

Green Shield Extended Healthcare Benefit

Benefit changes effective the first of the month following ratification of the Memorandum of Settlement by the parties:

- \$9.00 drug card system (drug plan is voluntary generic substitution).
- Vision Care (eyeglass subsidy \$450.00 every two years). Amount of Vision Care can be used for Eye Vision Lasik Surgery or contact lenses.
- One (1) eye examination by a licensed ophthalmologist or optometrist every twenty-four (24) consecutive months or when the Ministry of Transportation requests a complete physical including eye examination for the employee's drivers' licence.
- Pharmacy dispensing fees capped at \$10 per prescription. No O.T.C. drug coverage with the exception of those deemed by the insurer to be "life sustaining".
- Orthotics – 50% / 50% co-share.
- Orthodontic - \$2500.00 (effective Feb. 1, 2018)

Cap Private Duty Nursing @ ninety (90) – eight (8) hour shifts per year.

Long Term Disability to provide 60% of an employee's basic hourly rate after 26 weeks with Canada Pension Plan as a primary offset.

Coverages for Group Life Insurance and Long Term Disability Insurance shall normally be adjusted effective on the first day of February following, but adjustments arising from the terms of a new or revised agreement shall be made effective as soon as possible after the signing of the terms of the settlement. Coverage shall be in

---

~~accordance with the terms and conditions of Great West Life Policy #320925 Division 9.~~ Coverage shall be in accordance with the terms and conditions of each policy.

---

~~The inclusion of the policy number is for identification only and will not affect other articles of the Collective Agreement.~~

- **Active Employees Over Age 65**



Active employees over age 65 will enjoy the same benefits as active under age 65, except for LTD and AD&D, which will terminate on the day the employee attains age 65. Life Insurance: Reduce to \$10,000 fixed to retirement or age 70 max.

**Letters:**

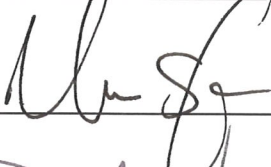
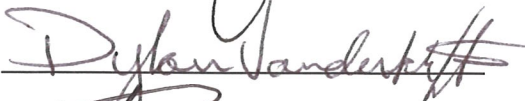

- #1 –Delete
- #2 – Renew and move into the body of the CA.
- #3 – Renew with changes
- #4- Renew.
- #6 –Renew.
- #9 – Renew & Move to Article 13:00.
- #13 – Renew & update ARTICLE number and deleted #3
- #14 –Delete

SIGNED AT SAULT STE. MARIE this 6<sup>th</sup> day of April, 2023

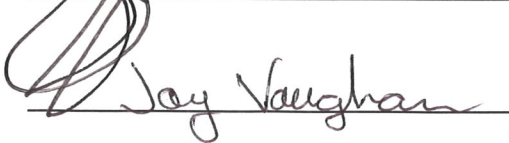
FOR ATU LOCAL 1767

  
\_\_\_\_\_  
  
\_\_\_\_\_  
  
\_\_\_\_\_  
  
\_\_\_\_\_  
\_\_\_\_\_

FOR CITY

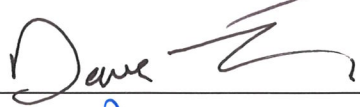
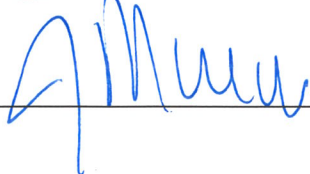
  
\_\_\_\_\_  
  
\_\_\_\_\_  
  
\_\_\_\_\_  
  
\_\_\_\_\_  
  
\_\_\_\_\_

Sign Off Sheet #3

ATU Local 1767

&

The City of Sault Ste. Marie

**ORIGINAL ARTICLE:**

14:06 After 25 years' continuous service the employee will be entitled to six (6) weeks of vacation plus one (1) additional day of vacation with pay at 12.5% of previous year's earnings.

After 26 years' continuous service the employee will be entitled to six (6) weeks of vacation plus two (2) additional days of vacation with pay at 13.0% of previous year's earnings.

After 27 years' continuous service the employee will be entitled to six (6) weeks of vacation plus three (3) additional days of vacation with pay at 13.5% of previous year's earnings.

After 28 years' continuous service the employee will be entitled to six (6) weeks of vacation plus three (3) additional days of vacation with pay at 13.5% of previous year's earnings.

After 29 years' continuous service the employee will be entitled to six (6) weeks of vacation plus three (3) additional days of vacation with pay at 13.5% of previous year's earnings.

14:07 After thirty (30) years continuous service the employee will be entitled to seven (7) weeks vacation with pay at 14% of their total wages paid to the employee the previous year.

14:08 Vacation Selection Schedule:

(a) Operators by seniority will select their vacation pick at scheduled times. Vacation pick periods will be scheduled at two hour intervals beginning November 1<sup>st</sup>, 7 A.M. to 5 P.M., continuing seven days a week until the first round vacation pick is completed. The second round of the vacation pick will begin the day following the completion of the first round vacation pick and will continue until completed.

Example:

November	1	Operator 1 to 5	
	2	Operator 6 to 10	1st round pick
	3	Operator 11 to 15	3 wks. selection
	14	Operator 81 to end	

November	15	Operator 1 to 5	
	16	Operator 6 to 10	2nd round pick
	17	Operator 11 to 15	remaining weeks

Daily time schedule:

Operator #1 -	7 AM to 9 AM
Operator #2 -	9 AM to 11 AM
Operator #3 -	11 AM to 1 PM
Operator #4 -	1 PM to 3 PM
Operator #5 -	3 PM to 5 PM

(b) Failure of an Operator to select their vacation pick in their scheduled time will result in the loss of their vacation pick until such time as they notify Transit Management of their desire to make their vacation picks. Upon notification to Transit Management of their desire to make a vacation pick, the Operator will be allowed to pick immediately after the Operator who is scheduled in that time frame makes their pick. The pick schedule will then continue on as scheduled.

(c) Operators who cannot be present to select their vacation pick will be permitted to telephone their choice or leave their choice with the Supervisor Transit Operations or the designate, who will record the pick on

behalf of the Operator.

(d) The Vacation Selection Schedule will be posted October 15<sup>th</sup> each year. Operators will be responsible to check their number and time schedule for their vacation pick, as numbers and times of selection may change each year.

14:09 Should an Operator be on L.T.D., Weekly Indemnity or WSIB at the time when their annual vacation is scheduled to occur, the vacations will be rescheduled to a time mutually agreed to between the employee and their Supervisor and will be rescheduled within two weeks of return to work, from among vacation openings existing as of January 1<sup>st</sup> of that calendar year.

**PROPOSED ARTICLE:**

14:06 **Employees who have completed 24 years' continuous service and are in their 25<sup>th</sup> year** will be entitled to six (6) weeks of vacation plus one (1) additional day of vacation with pay at 12.5% of previous year's earnings.

**Employees who have completed 25 years' continuous service and are in their 26<sup>th</sup> year** will be entitled to six (6) weeks of vacation plus two (2) additional days of vacation with pay at 13.0% of previous year's earnings.

**Employees who have completed 26 years' continuous service and are in their 27<sup>th</sup> year through to their 29<sup>th</sup> year** will be entitled to six (6) weeks of vacation plus three (3) additional days of vacation with pay at 13.5% of previous year's earnings.

~~**Employees who have completed 27 years' continuous service and are in their 28<sup>th</sup> year** will be entitled to six (6) weeks of vacation plus three (3) additional days of vacation with pay at 13.5% of previous year's earnings.~~

~~Employees who have completed 28 years' continuous service and are in their 29<sup>th</sup> year will be entitled to six (6) weeks of vacation plus three (3) additional days of vacation with pay at 13.5% of previous year's earnings~~

14:07 After thirty (30) years continuous service the employee will be entitled to seven (7) weeks vacation with pay at 14% of their total wages paid to the employee the previous year.

14:08 Vacation Selection Schedule:

- (a) Operators by seniority will select their vacation pick at scheduled times. Vacation pick periods will be scheduled at two hour intervals beginning November 1<sup>st</sup>, 7 A.M. to 5 P.M., continuing seven days a week until the first round vacation pick is completed. The second round of the vacation pick will begin the day following the completion of the first round vacation pick and will continue until completed.

Example:

November	1	Operator 1 to 5	
	2	Operator 6 to 10	1st round pick
	3	Operator 11 to 15	3 wks. selection
	14	Operator 81 to end	
November	15	Operator 1 to 5	
	16	Operator 6 to 10	2nd round pick
	17	Operator 11 to 15	remaining weeks

Daily time schedule:

- Operator #1 - 7 AM to 9 AM
- Operator #2 - 9 AM to 11 AM
- Operator #3 - 11 AM to 1 PM
- Operator #4 - 1 PM to 3 PM

Operator #5 - 3 PM to 5 PM

(b) **It is the sole responsibility of the Operator to know their pick time.**

Failure of an Operator to select their vacation pick in their scheduled time will result in the loss of their vacation pick until such time as they notify Transit Management of their desire to make their vacation picks. Upon notification to Transit Management of their desire to make a vacation pick, the Operator will be allowed to pick immediately after the Operator who is scheduled in that time frame makes their pick. The pick schedule will then continue on as scheduled.

(c) Operators who cannot be present to select their vacation pick will be permitted to telephone their choice. ~~or leave their choice with the Supervisor Transit Operations or the designate, who will record the pick on behalf of the Operator.~~

(d) The Vacation Selection Schedule will be posted October 15<sup>th</sup> each year. Operators will be responsible to check their number and time schedule for their vacation pick, as numbers and times of selection may change each year.

14:09 Should an Operator be on L.T.D., Weekly Indemnity or WSIB at the time when their annual vacation is scheduled to occur, the vacations will be rescheduled to a time mutually agreed to between the employee and their Supervisor and will be rescheduled within two weeks of return to work, from among vacation openings existing as of January 1<sup>st</sup> of that calendar year.

**LETTER #13**

**LETTER OF UNDERSTANDING**

**BETWEEN**

**AMALGAMATED TRANSIT UNION LOCAL 1767**

**AND**



THE CITY OF SAULT STE. MARIE

ORIGINAL

USE OF VACATION FLOATER DAYS

It is agreed and understood that Operators with Floating Vacation Days remaining to be booked after the regular booking period referred to in Article 15, may use such days the following year, to cover days where an Operator is ill provided the following:

1. The City reserves the right to ask for a medical note verifying the reason for absence (illness) in accordance with Article 16:04.
2. The employee/operator must declare that the floating vacation day is being requested for illness absence within 24 hours of the call in.
3. This letter will be in effect for a trial period of two (2) years beginning January 1, 2016.
4. This letter is subject to renewal by mutual agreement of the parties.

Agreed to this 20<sup>th</sup> day of June, 2019.

FOR THE UNION

FOR THE CITY

"Dennis Champagne"

"Brad Miller"

"Brent Cerenzia"

"Nicole Maione"

"Alfred D'Ettorre"

"Brent Lamming"

"Manny Sforza"

"Ida Bruno"

"Peter N"

**PROPOSED**

**LETTER #13**

**LETTER OF UNDERSTANDING**

**BETWEEN**

**AMALGAMATED TRANSIT UNION LOCAL 1767**

**AND**

**THE CITY OF SAULT STE. MARIE**

**USE OF VACATION FLOATER DAYS**

It is agreed and understood that Operators with Floating Vacation Days remaining to be booked after the regular booking period referred to in Article 15, may use such days the following year, to cover days where an Operator is ill provided the following:



1. The City reserves the right to ask for a medical note verifying the reason for absence (illness) in accordance with Article 16:04 **15.04.**
2. The employee/operator must declare that the floating vacation day is being requested for illness absence within 24 hours of the call in.
3. ~~This letter will be in effect for a trial period of two (2) years beginning January 1, 2016.~~
4. This letter is subject to renewal by mutual agreement of the parties.

SIGNED AT SAULT STE. MARIE this 25<sup>th</sup> day of April, 2023

FOR ATU LOCAL 1767

  
\_\_\_\_\_  
Jeff Vaughan  
\_\_\_\_\_  
Dylan Vanderkuff  
\_\_\_\_\_  
WJ  
\_\_\_\_\_  
\_\_\_\_\_

FOR CITY

  
\_\_\_\_\_  
  
\_\_\_\_\_  
  
\_\_\_\_\_  
Dave  
\_\_\_\_\_  
But  
\_\_\_\_\_  
Justin Palmer  
\_\_\_\_\_

Sign Off Sheet #4

ATU Local 1767

&

The City of Sault Ste. Marie

**\*\* Insert above last paragraph in 9:01 a) which begins with “Regular assigned Operators will be allowed to forfeit...”**

Operators who cannot be present to select their pick will be permitted to leave their choices in order of preference with the Supervisor Transit Operations or the designate, who will record the pick on behalf of the Operator.

**ORIGINAL**

- 11:02 (a) Ten (10) hours will constitute a day’s work for all Regular Operators with the exception of those Regular Operators on Parabus assignments who will have a regular workday of eight (8) hours. Rates of time and one half to the closest 5 minutes will be paid for all:
- hours worked or held for duty in excess of ten (10) hours per day or eight (8) hours per day if a Regular Para Bus Operator;
  - in excess of 80 pro rata hours in a two week pay period;

Pay period earnings will be calculated with one-week vacation equaling 40 hours in the calculation of overtime.

There will be no pyramiding of overtime hours.

**PROPOSED**

- 11:02 (a) Ten (10) hours will constitute a day’s work for all Regular Operators with the exception of those Regular Operators on Parabus assignments who will have a regular workday of eight (8) hours. Rates of time and one half to the closest 5 minutes will be paid for all:
- hours worked or held for duty in excess of ten (10) hours per day or eight (8) hours per day if a Regular Para Bus Operator;
  - in excess of 80 pro rata **(portion)** hours in a two week pay period;

Pay period earnings will be calculated with one-week vacation equaling 40 hours in the calculation of overtime.

There will be no pyramiding of overtime hours.

**ORIGINAL**

11:06 Regular Operators will be allowed to change their scheduled shifts daily, weekly, or for the duration of the pick. Vacation is part of the scheduled change when Operators switch for the duration of the pick.

No Operator will work more than eleven (11) consecutive shifts in order to facilitate shift changes. The shift change and the payback must be marked up together.

All shift changes involving Spareboard must be approved by the Employer three (3) days prior to change date.

**PROPOSED**

11:06 Regular Operators will be allowed to change their scheduled shifts daily, weekly, or for the duration of the pick. Vacation is part of the scheduled change when Operators switch for the duration of the pick.

**Trades that include at least one Spareboard Operator will result in both Operators being removed from the Cover List for the day of the Trade.**

No Operator will work more than eleven (11) consecutive shifts in order to facilitate shift changes. The shift change and the payback must be marked up together.

~~All shift changes involving Spareboard must be approved by the Employer three (3) days prior to change date.~~

**ADD NEW CLAUSE 11:09**

**(Union proposed 11:13)**

The Scheduler or Designate will make every effort to email the schedule on or about 4:00 pm daily (Monday-Friday). Weekend schedules will be emailed on Friday. Spareboard operators who want to be included on this daily email may opt in by emailing the Scheduler. The schedule is subject to change. After 4:00 pm any changes to the schedule will be called out to the affected Spareboard operators.

**ORIGINAL**

**LETTER #11**

**LETTER OF UNDERSTANDING**

**BETWEEN**

**AMALGAMATED TRANSIT UNION LOCAL 1767**

**AND**

**THE CITY OF SAULT STE.  
MARIE**

**PAID APPROVED UNION LEAVES (P.A.U.L.)**

The City agrees to maintain the wages of an employee on Paid Approved Union Leave subject to the following conditions:

The Union shall provide WSIB coverage for members on Leave for Union Business.

The Union shall provide to the City initially and at any time upon request thereafter its WSIB Clearance Certificate to verify it has such valid coverage. The Union shall also provide to the City its WSIB account number. It is the responsibility of the Union to maintain such coverage. Failure of the Union to maintain such coverage shall make this agreement null and void. The City will not be responsible for WSIB coverage when an employee is on such leave.

The agreement shall state that the Union will promptly reimburse the City within thirty (30) days of the date of the invoice for the amounts owing for such leaves.

The City will issue such invoices on a frequency of no greater than once per month.

For each employee granted such leave, it will appear as a separate code (Paid Approved Union Leave – P.A.U.L.) on the employee's pay stub and the City shall invoice for reimbursement from the respective Union the amount of wages, Employer Health Tax, City OMERS share, City share of CPP and City share of EI.

For approved leaves of twenty (20) working days or more, the Union shall also reimburse the City the monthly benefit premiums for Extended Health Care,

Dental Plan, Life & ADD, W.I. and LTD. Also, the City will invoice for the applicable vacation entitlement percentage (2% per week of vacation entitlement) for the period of absence.

In addition to the previously noted amounts, the City shall bill the Union on each invoice the amount of one and a half (1.5) hours at the CUPE 67 Civic JC 12 rate for the preparation of such invoice.

The City shall send the invoice for such reimbursement to the address designated by the Union.

Requests for Leave for Union Business shall be on a form provided by the City for approval by the respective Department Head and distributed to Accounting Division with a copy to the Human Resources Department.

Agreed to this 20th day of June, 2019.

FOR THE UNION

FOR THE CITY

"Dennis Champagne"

"Brent Cerenzia"

"Alfred D'Ettorre"

"Manny Sforza"

"Brad Miller"

"Nicole Maione"

"Brent Lamming"

"Ida Bruno"

"Peter Niro"

**PROPOSED**

**LETTER #11**

**LETTER OF UNDERSTANDING**

**BETWEEN**

**AMALGAMATED TRANSIT UNION LOCAL 1767**

**AND**

**THE CITY OF SAULT STE.  
MARIE**

**PAID APPROVED UNION LEAVES (P.A.U.L.)**

The City agrees to maintain the wages of an employee on Paid Approved Union Leave subject to the following conditions:

The Union shall provide WSIB coverage for members on Leave for Union Business.

The Union shall provide to the City initially and at any time upon request thereafter its WSIB Clearance Certificate to verify it has such valid coverage. The Union shall also provide to the City its WSIB account number. It is the responsibility of the Union to maintain such coverage. Failure of the Union to maintain such coverage shall make this agreement null and void. The City will not be responsible for WSIB coverage when an employee is on such leave.

The agreement shall state that the Union will promptly reimburse the City within thirty (30) days of the date of the invoice for the amounts owing for such leaves.

The City will issue such invoices on a frequency of no greater than once per month.

For each employee granted such leave, it will appear as a separate code (Paid Approved Union Leave – P.A.U.L.) on the employee's pay stub and the City shall invoice for reimbursement from the respective Union the amount of wages, Employer Health Tax, City OMERS share, City share of CPP and City share of EI.

For approved leaves of twenty (20) working days or more, the Union shall also reimburse the City the monthly benefit premiums for Extended Health Care,

Dental Plan, Life & ADD, W.I. and LTD. Also, the City will invoice for the applicable vacation entitlement percentage (2% per week of vacation entitlement) for the period of absence.

In addition to the previously noted amounts, the City shall bill the Union on each invoice the amount of one and a half (1.5) hours at the CUPE 67 Civic JC 12 rate for the preparation of such invoice.

The City shall send the invoice for such reimbursement to the address designated by the Union.

Requests for Leave for Union Business shall be on a form provided by the City for approval by the respective Department Head and distributed to Accounting Division with a copy to the Human Resources Department.



Reasonable effort must be made to submit these requests a minimum of one (1) week prior to the requested date. Approval is based on operational needs, and will not be unreasonably withheld.

Agreed to this 26<sup>th</sup> day of April, 2023

FOR ATU LOCAL 1767

  
\_\_\_\_\_  
Roy Vaughan  
\_\_\_\_\_

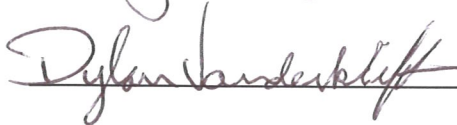
  
\_\_\_\_\_  
Dylan Vanderkuff  
\_\_\_\_\_

FOR CITY

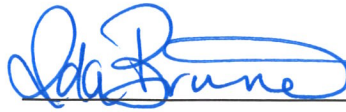
  
\_\_\_\_\_  
Ida Brune  
\_\_\_\_\_

  
\_\_\_\_\_  
Nicole Ottolenghi  
\_\_\_\_\_

  
\_\_\_\_\_  
J. Muench  
\_\_\_\_\_

  
\_\_\_\_\_  
Dave Z  
\_\_\_\_\_

  
\_\_\_\_\_  
BTL  
\_\_\_\_\_

SIGNED AT SAULT STE. MARIE this 26<sup>th</sup> day of April, 2023

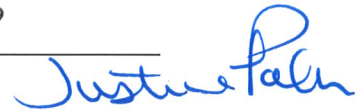
  
Justice Palm

FOR ATU LOCAL 1767

  
\_\_\_\_\_  
Roy Vaughan  
\_\_\_\_\_

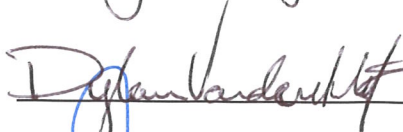
  
\_\_\_\_\_  
Dylan Vanderkuff  
\_\_\_\_\_

  
\_\_\_\_\_  
J. Muench  
\_\_\_\_\_

FOR CITY

  
\_\_\_\_\_  
Ida Brune  
\_\_\_\_\_

  
\_\_\_\_\_  
Nicole Ottolenghi  
\_\_\_\_\_

  
\_\_\_\_\_  
J. Muench  
\_\_\_\_\_

  
\_\_\_\_\_  
Dave Z  
\_\_\_\_\_

  
\_\_\_\_\_  
BTL  
\_\_\_\_\_

  
Justice Palm

Sign Off Sheet #5

ATU Local 1767

&

The City of Sault Ste. Marie

**ORIGINAL**

**11:03** The Overtime Call List will be posted with the regular run pick and will remain in effect for the duration of the pick. Regular operators must sign this list to be eligible to work overtime. Operators who sign off the Overtime Call List will not be eligible to sign on until they notify the Area Coordinator Transit & Parking or the designate in writing of their intent. Such Operators will have their names placed at the bottom of the Overtime List. Spareboard operators will automatically be placed on the Overtime Call List.

Operators who have signed the overtime call list will be called in seniority rotation so that overtime turns are distributed as equitably as possible. A turn of overtime will be equal to ten (10) hours worked or refused.

When an Operator is called for overtime service and fails to respond, the Operator loses their overtime turn, except those Operators on vacation, on W.S.I.B., or on paid sick leave, will not be charged a turn of overtime. Refusing short changes (less than 8 hours) will not be recorded as a refusal.

A chart will be posted weekly for each pick period indicating the hours of overtime worked or refused by each Operator. The hours of worked or refused overtime will be active for the duration of the pick period. Any imbalances in the equitable distribution of overtime hours will be corrected as soon as practically possible.

**PROPOSED**

**11:03** The Overtime Call List will be posted with the regular run pick and will remain in effect for the duration of the pick. Regular operators must sign this list to be eligible to work overtime. Operators who sign off the Overtime Call List will not be eligible to sign on until they notify the Area Coordinator Transit & Parking or the designate in writing of their intent. Such Operators will have their names placed at the bottom of the Overtime List. Spareboard operators will automatically be placed on the Overtime Call List.

**The most senior top three Spareboard Operators who elect to start their shifts on Monday can be called for over time on Sunday with the hours being paid out at an overtime rate and not included in their 40 hours per week, or 80 hours over two weeks.**

**In the calculation of overtime (OT) hours for Spareboard Operators, OT will**

**not be included in the scheduled hours at regular pay.**

Operators who have signed the overtime call list will be called in seniority rotation so that overtime turns are distributed as equitably as possible. A turn of overtime will be equal to ten (10) hours worked or refused.

When an Operator is called for overtime service and fails to respond, the Operator loses their overtime turn, except those Operators on vacation, on W.S.I.B., or on paid sick leave, will not be charged a turn of overtime. Refusing short changes (less than 8 hours) will not be recorded as a refusal.

**Those Operators who wish to be called for overtime while on vacation will be called once the list is exhausted.**

A chart will be posted weekly for each pick period indicating the hours of overtime worked or refused by each Operator. The hours of worked or refused overtime will be active for the duration of the pick period. Any imbalances in the equitable distribution of overtime hours will be corrected as soon as practically possible.

**ADD NEW**

**11:11**

The operator will be able to make up their lost hours at regular pay as a result of a book off. This will occur only if:

- there is no spareboard operator available;
- the employer has shifts available on the schedule in the same pay period, including operator's regular day off;
- it prevents filling overtime

The operator involved will contact the Area Coordinator on the day of the book off to make themselves available for potential work.

**ADD NEW**

**11:12**

**SCHEDULING OF SPAREBOARD HOURS**

- |    |  |                      |    |                       |           |
|----|--|----------------------|----|-----------------------|-----------|
| 1. | 2:20 p.m. – 12:05 a.m.                     | 9.75 hrs.            | 2. | 5:40 a.m. – 3:00 p.m. | 9.33 hrs. |
| 3. | 6:15 a.m. – 3:30 p.m.                      | 9.25 hrs.            |    |                       |           |
| 4. | Full Para bus shifts 9.25 hours or greater |                      |    |                       |           |
| 5. | <del>6:45 a.m. — 3:30 p.m.</del>           | <del>8.75 hrs.</del> |    |                       |           |
| 6. | <del>3:20 p.m. — 12:05 a.m.</del>          | <del>8.75 hrs.</del> |    |                       |           |

7. 5:40 a.m.— 2:00 p.m. 8.33

hrs.

8. 6:15 a.m.— 2:30 p.m. 8.25

hrs.

~~9. Weekend shifts will follow the same pattern of descending hours starting with 10-hour shifts and completing with 8.17-hour shifts~~

All employees in the first four (4) categories will be removed from the cover list.

All other work will be scheduled such that the maximum number of available hours will be assigned according to seniority. This may result in a senior employee being assigned to several pieces of work. As a result, a senior employee may start and/or end work later in the day than a junior employee.

In the event of cancellations, reasonable attempts will be made to re-assign additional hours that same day. Such attempts will be the responsibility of the Scheduler and/or the Inspector on duty at the time of cancellations.

If it is not logistically or economically feasible to make up canceled hours on the day that a cancellation occurs, then the affected employee will be allowed to make up the lost hours by the end of the pay week or pay period where possible.

This priority list is only a guideline and spare board operators will be used as needed, not to interrupt the Transit Service.

The daily schedule will be posted by 4:00 p.m. Monday to Friday and any book offs after 4:00 p.m. are to be reassigned to the cover list.

## **ORIGINAL**

### **LETTER #12**

### **LETTER OF UNDERSTANDING**

### **BETWEEN**

### **AMALGAMATED TRANSIT UNION LOCAL 1767**

### **AND**

### **THE CITY OF SAULT STE. MARIE**

### **SHIFT DIFFERENTIALS**

It is agreed and understood that twenty-five cents (\$0.25) per hour forms part of the hourly rates under 13:01 of the collective agreement in lieu of all shift differentials, Sunday premium and Para bus training premium.

**PROPOSED**

**LETTER #12**

**LETTER OF UNDERSTANDING**

**BETWEEN**

**~~AMALGAMATED TRANSIT UNION LOCAL 1767~~**

**AND**

**~~THE CITY OF SAULT STE. MARIE~~**

**SHIFT DIFFERENTIALS**





~~It is agreed and understood that twenty five cents (\$0.25) per hour forms part of the hourly rates under 13:01 of the collective agreement in lieu of all shift differentials, Sunday premium and Para bus training premium.~~

SIGNED AT SAULT STE. MARIE this 26<sup>th</sup> day of April, 2023

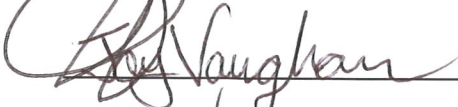
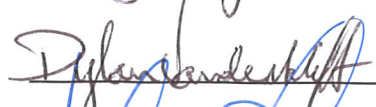
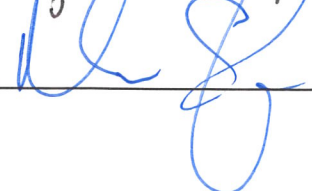
FOR ATU LOCAL 1767

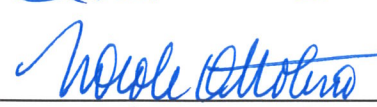
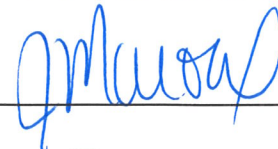
FOR CITY

  
\_\_\_\_\_  
  
\_\_\_\_\_  
  
\_\_\_\_\_  
  
\_\_\_\_\_  
\_\_\_\_\_

  
\_\_\_\_\_  
  
\_\_\_\_\_  
  
\_\_\_\_\_  
  
\_\_\_\_\_  
  
\_\_\_\_\_  
  
\_\_\_\_\_

LETTER OF AGREEMENT

BETWEEN:

The Corporation of the City of Sault Ste. Marie

(Hereinafter referred to as the "City")

-and-

Amalgamated Transit Union Local 1767

(Hereinafter referred to as the "Union")



WHEREAS the Collective Agreement has included references to Shortchanges, which has been a long standing practice;



AND WHEREAS the Union has advised that they require a change to this practice before continuing to negotiate any further section of the Collective Agreement;

NOW THEREFORE the parties agree as follows:

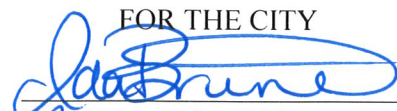
1. A spareboard employee may not be entitled to the greatest piece of work (highest hours) and the City shall go to the next most senior person who has been free from work for at least 8 hours; They shall be assigned the first known full piece(s) of work after 8 hours free from work. If no full piece of work is available then partial pieces of work may be added together.
2. The Union and Employee agree that a driver won't be eligible for overtime if they have not been off for 8 consecutive hours in between days.
3. No grievances specifically related to spareboard work being assigned out of value order shall arise out of the implementation of this agreement from the Union.
4. This rest period does not apply to split shifts within the same day.
5. This agreement will be in effect April 6, 2023 until such time that the Memorandum of Settlement is ratified by both parties.
6. This LOA is without P&P and is no admission of liability.

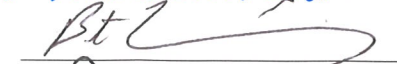
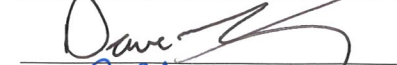
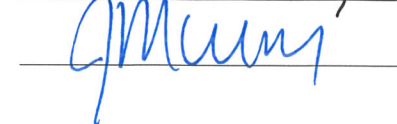
DATED 5<sup>th</sup>, day of April, 2023.

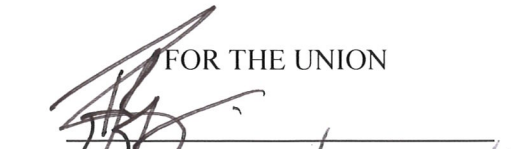
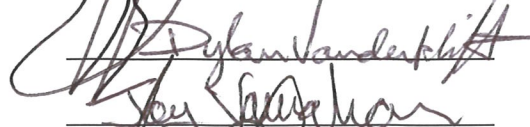
FOR THE CITY  
  
  
  
  

FOR THE UNION  
  
  

**Sign Off Sheet #6**  
**ATU Local 1767**  
**&**  
**The City of Sault Ste. Marie**

**Article 12:00 Rates of Pay**

To be applied to table

**2023 3.50%**

**2024 3.75% (effective January 1, 2024)**

**2025 3.0% (effective February 1, 2025)**

**2026 3.0% (effective February 1, 2026)**

---

**EXISTING ARTICLE**

**ARTICLE 15:00 WELFARE**

15:01 The City agrees to provide the following welfare benefits to employees classified as Operator II with the City paying 100% of the premiums for such benefits:

Ontario Health Insurance Plan

Life Insurance plus A.D. & D. \$38,000.00

Weekly Accident and Sickness Benefit – Effective January 1, 2016:

The amount of the Weekly Accident and Sickness Benefit shall be sixty percent (60%) of basic weekly earnings. It is understood and agreed by the parties that in return for this benefit the full U.I.C. rebate

on premiums shall be retained by the City.

Green Shield Extended Healthcare Benefit

Benefit changes effective the first of the month following ratification of the Memorandum of Settlement by the parties:

- \$9.00 drug card system (drug plan is voluntary generic substitution).

- Vision Care (eyeglass subsidy \$450.00 every two years). Amount of Vision Care can be used for Eye Vision Lasik Surgery or contact lenses.
- One (1) eye examination by a licensed ophthalmologist or optometrist every twenty-four (24) consecutive months or when the Ministry of Transportation requests a complete physical including eye examination for the employee's drivers' licence.
- Pharmacy dispensing fees capped at \$10 per prescription. No O.T.C. drug coverage with the exception of those deemed by the insurer to be "life sustaining".
- Orthotics – 50% / 50% co-share.
- Orthodontic - \$2500.00 (effective Feb. 1, 2018)

Cap Private Duty Nursing @ ninety (90) – eight (8) hour shifts per year.

Long Term Disability to provide 60% of an employee's basic hourly rate after 26 weeks with Canada Pension Plan as a primary offset.

Coverages for Group Life Insurance and Long Term Disability Insurance shall normally be adjusted effective on the first day of February following, but adjustments arising from the terms of a new or revised agreement shall be made effective as soon as possible after the signing of the terms of the settlement. Coverage shall be in

accordance with the terms and conditions of Great West Life Policy #320925 Division 9.

The inclusion of the policy number is for identification only and will not affect other articles of the Collective Agreement.

- **Active Employees Over Age 65**

Active employees over age 65 will enjoy the same benefits as active under age 65, except for LTD and AD&D, which will terminate on the day the employee attains age 65. Life Insurance: Reduce to \$10,000 fixed to retirement or age 70 max.

15:02 Employees will be provided with Green Shield Dental Plan #9 with Rider #3 (\$1,500 orthodontic limit), on the basis of one year behind current O.D.A. fee schedule.



- 15:03 Overage Dependent Coverage to age twenty-five (25) is included in the Green Shield Extended Health Care and Dental coverage.
- 15:04 An employee absent on sick leave must furnish a medical certificate stating the nature of their illness if requested by Management.
- An employee on sick leave for 30 days or more must furnish a certificate to return to duty.
- The City will reimburse the employee up to \$40 for medical information requested by the Employer (The City). This does include Great West Life forms.
- Cost of medical notes to substantiate absences when an employee has been referred to the Attendance Management Program will not be reimbursed and is the responsibility of the employee.
- 15:05 An employee hurt in an industrial accident shall be paid for the scheduled time lost on the day the employee was injured at their regular rate including any overtime premium.
- 15:06 The City shall provide transportation pay for the time spent by employees during their regular shift hours for medical treatment required as a result of an industrial accident or industrial disease incurred or contracted while in the employ of the City. It is not the
- intent of the above provisions to make the City responsible for the payment of such time and transportation which is compensated by WSIB.
- 15:07 An employee who is absent from work without pay for 30 days or more shall be fully responsible for the payment of the total cost of premiums for the benefits outlined in Articles 15:01 and 15:02.
- 15:08 Every employee shall be fully responsible for keeping the City informed of changes in their marital status or the number of dependents within 15 days of the change. The Corporation shall have the right to recover by payroll deduction, any amounts of premiums paid in excess of such proper premiums as a result of not being properly informed by an employee of their status for the purpose of insurance and medical coverages.
- 15:09 The City shall have the right to determine the carrier of such benefits. All refunds, reduction of premiums, dividends, etc., shall become and remain the sole property of the City. Benefits under any such plan or plans shall not be reduced by the City without the consent of the Union.

15:10 An employee who takes other gainful employment during absence from work due to illness or injury shall be deemed to have voluntarily quit their employment unless the employee has prior written permission from the Director of Human Resources to take other employment.

15:11 (a) Operator I

New Operators *hired on or after April 1, 2003* will be provided with the following welfare benefits during the first three thousand seven hundred and fifty (3,750) hours of work with 100% of the premium paid by the City:

- Prescription Drug Benefit Plan at 90/10% Co-insurance
  - \* Drug benefit subject to elimination of OTC's & \$8 dispensing fee cap.
- Vision Care \$100 per 24 months

(b) While it is understood that employees in the Operator I and Operator II classifications may work on an as required basis, the inclusion of this clause is not to be interpreted as Part-Time Employees.

## PROPOSED ARTICLE:

### ARTICLE 15:00 WELFARE

15:01 The City agrees to provide the following welfare benefits to employees classified as Operator II with the City paying 100% of the premiums for such benefits:

Ontario Health Insurance Plan

Life Insurance plus A.D. & D. \$38,000.00 **\$50,000 in the amount of 1.5 times annual salary.**

Weekly Accident and Sickness Benefit – Effective January 1, 2016:

The amount of the ~~Weekly Accident and Sickness Benefit~~ **Short Term Disability** shall be ~~sixty~~ **seventy** percent (~~60%~~) (**70%**) of basic weekly earnings. It is understood and agreed by the parties that in return for this benefit the full U.I.C. rebate on premiums shall be retained by the City.

Green Shield Extended Healthcare Benefit

Benefit changes effective the first of the month following ratification of the Memorandum of Settlement by the parties:

- \$9.00 drug card system (drug plan is voluntary generic substitution).
- Vision Care (eyeglass subsidy ~~\$450.00~~ **\$500** every two years **for the life of the agreement.**) Amount of Vision Care can be used for Eye Vision Lasik Surgery or contact lenses.
- One (1) eye examination by a licensed ophthalmologist or optometrist every twenty-four (24) consecutive months or when the Ministry of Transportation requests a complete physical including eye examination for the employee's drivers' licence.
- Pharmacy dispensing fees capped at \$10 per prescription. No O.T.C. drug coverage with the exception of those deemed by the insurer to be "life sustaining".
- Orthotics – 50% / 50% co-share.
- Orthodontic - ~~\$2500.00 (effective Feb. 1, 2018)~~

**Delete this:**

**Physiotherapist, Osteopath, Podiatrist, Chiropodist, Naturopath, Registered Massage Therapist (medical referral required) or Speech Therapist: \$20 per visit  
Chiropractor: \$20 per visit, plus up to a maximum of \$45 per calendar year for X-rays: Podiatrist Surgery: up to a maximum of \$200 per calendar year**

**Add in:**

**\$500 Combined Paramedical Benefit for Physiotherapist, Osteopath, Podiatrist, Chiropodist, Naturopath, Registered Massage Therapist (medical referral required), Chiropractor or Speech Therapist**

**Add in:**

**Premium Maple and InkBlot. Both will be effective the 1<sup>st</sup> of the month following ratification by both parties.**

Cap Private Duty Nursing @ ninety (90) – eight (8) hour shifts per year.

Long Term Disability to provide 60% of an employee's basic hourly rate after 26 weeks with Canada Pension Plan as a primary offset.

Coverages for Group Life Insurance and Long Term Disability Insurance shall normally be adjusted effective on the first day of February following, but adjustments arising from the terms of a new or revised agreement shall be made effective as soon as possible after the signing of the terms of the settlement. Coverage shall be in accordance with the terms and conditions **of each policy.** ~~Great West Life Policy #320925 Division 9.~~

~~The inclusion of the policy number is for identification only and will not affect other articles of the Collective Agreement.~~

- **Active Employees Over Age 65**

Active employees over age 65 will enjoy the same benefits as active under age 65, except for LTD and AD&D, which will terminate on the day the employee attains age 65. Life Insurance: Reduce to \$10,000 fixed to retirement or age 70 max.

15:02 Employees will be provided with Green Shield Dental Plan #9 with Rider #3 (\$1,500 orthodontic limit), on the basis of one year behind current O.D.A. fee schedule.

15:03 Overage Dependent Coverage to age twenty-five (25) is included in the Green Shield Extended Health Care and Dental coverage.

15:04 An employee absent on sick leave must furnish a medical certificate stating the nature of their illness if requested by Management.

An employee on sick leave for 30 days or more must furnish a certificate to return to duty.

The City will reimburse the employee up to \$40 for medical information requested by the Employer (The City). This does includes Great West Life STD carrier forms.

Cost of medical notes to substantiate absences when an employee has been referred to the Attendance Management Program will not be reimbursed and is the responsibility of the employee.

15:05 An employee hurt in an industrial accident shall be paid for the scheduled time lost on the day the employee was injured at their regular rate including any overtime premium.

15:06 The City shall provide transportation pay for the time spent by employees during their regular shift hours for medical treatment required as a result of an industrial accident or industrial disease incurred or contracted while in the employ of the City. It is not the

intent of the above provisions to make the City responsible for the payment of such time and transportation which is compensated by WSIB.

- 15:07 An employee who is absent from work without pay for 30 days or more shall be fully responsible for the payment of the total cost of premiums for the benefits outlined in Articles 15:01 and 15:02.
- 15:08 Every employee shall be fully responsible for keeping the City informed of changes in their marital status or the number of dependents within 15 days of the change. The Corporation shall have the right to recover by payroll deduction, any amounts of premiums paid in excess of such proper premiums as a result of not being properly informed by an employee of their status for the purpose of insurance and medical coverages.
- 15:09 The City shall have the right to determine the carrier of such benefits. All refunds, reduction of premiums, dividends, etc., shall become and remain the sole property of the City. Benefits under any such plan or plans shall not be reduced by the City without the consent of the Union.
- 15:10 An employee who takes other gainful employment during absence from work due to illness or injury shall be deemed to have voluntarily quit their employment unless the employee has prior written permission from the Director of Human Resources to take other employment.
- 15:11 ~~(a) Operator I~~

New Operators *hired on or after April 1, 2003* will be provided with the following welfare benefits during the first three thousand seven hundred and fifty (3,750) hours of work with 100% of the premium paid by the City:

- Prescription Drug Benefit Plan at 90/10% Co-insurance  
\* Drug benefit subject to elimination of OTC's & ~~\$8~~ **\$10** dispensing fee cap.
- Vision Care- ~~\$100 per 24 months~~ **\$500 effective February 1, 2023 per 24 months for the life of the agreement.**

~~(b) While it is understood that employees in the Operator I and Operator II classifications may work on an as required basis, the inclusion of this clause is not to be interpreted as Part Time Employees.~~

**\*\*\* To appear in the MOS only- remove EAP.**

## EXISTING ARTICLE

### ARTICLE 19:00 DURATION

- 19:01 This Agreement shall be effective from February 1<sup>st</sup>, 2015 and shall remain in effect until January 31<sup>st</sup>, 2019 and shall thereafter continue from year to year unless not more than one hundred and twenty (120) days nor less than 30 days before the expiration date, either party shall give written notice to the

other party that it desires revision, modification or termination of this Agreement at its expiration date. Negotiations shall then be scheduled between said parties within ten (10) days of such notice.

**PROPOSED ARTICLE**

**ARTICLE 19:00 DURATION**

19:01 This Agreement shall be effective from February 1<sup>st</sup>, ~~2015~~ **2023** and shall remain in effect until January 31<sup>st</sup>, ~~2019~~ **2027** and shall thereafter continue from year to year unless not more than one hundred and twenty (120) days nor less than 30 days before the expiration date, either party shall give written notice to the other party that it desires revision, modification or termination of this Agreement at its expiration date. Negotiations shall then be scheduled between said parties within ten (10) days of such notice.

**ORIGINAL LETTER:**

**LETTER #5  
LETTER OF  
UNDERSTANDING  
BETWEEN  
AMALGAMATED TRANSIT UNION LOCAL  
1767 AND  
THE CITY OF SAULT STE. MARIE  
UNIFORM POINT  
SYSTEM  
(Effective 2019)**

All uniforms must be worn according to Transit

Item of Clothing	Value
1 pair of men's or women's trousers	3 points
1 dress shirt (long or short sleeve)	1 point
1 polo shirt	2 points
1 windbreaker	2 points
1 winter coat	9 points
1 fall jacket	4 points
1 rain coat	2 points
1 half zip pullover	2 points
2 baseball caps	1 point
1 pair mechanic gloves	1 point
1 pair shorts	2 points

Every new operator will receive 2 pairs of trousers, 6 shirts (dress or polo combined), 1 winter coat, 1 windbreaker, 2 pairs of shorts, 1 rain coat, 1 baseball cap.

Note: Upon successful completion of the probationary period, employees will accumulate fourteen (14) points for each calendar year of service (January to December). Points will be prorated for absence from work due to W.I., W.S.I.B., or Leave of Absence for thirty (30) or more cumulative days of absence in any given calendar year.

The parties agree to meet during the term of this collective agreement to

discuss the point system and the quality of the garments to be purchased. Within 90 days from ratification.

Agreed to this 20th day of June, 2019.

FOR THE UNION

"Dennis Champagne"  
"Brent Cerenzia"  
"Alfred D'Ettorre"  
"Manny Sforza"

FOR THE CITY

"Brad Miller"  
"Nicole Maione"  
"Brent Lamming"  
"Ida  
Bruno  
 "

"Peter  
Niro"

LETTER #5  
LETTER OF  
UNDERSTANDING  
BETWEEN  
AMALGAMATED TRANSIT UNION LOCAL 1767  
AND  
THE CITY OF SAULT STE. MARIE

UNIFORM POINT  
SYSTEM  
(Effective 202319)

All uniforms must be worn according to Transit Policy.

Item of Clothing	Value
1 pair of men's or women's trousers	3 points
1 dress shirt (long or short sleeve)	1 point
1 polo shirt	2 points
1 windbreaker	2 points
1 winter coat	9 points
1 fall jacket	4 points
1 rain coat	2 points
1 half zip pullover	2 points
2 baseball caps	1 point
1 pair mechanic gloves	1 point
1 pair shorts	2 points

**Move to Article 17 and uniform orders will be placed every two (2) years.**

Every new operator will receive 2 pairs of trousers, 6 shirts (dress or polo combined), 1 winter coat, 1 windbreaker, 2 pairs of shorts, 1 rain coat, 1 baseball cap.



Note: Upon successful completion of the probationary period, employees will accumulate fourteen (14) points for each calendar year of service (January to December). Points will be prorated for absence from work due to W.I., W.S.I.B., or Leave of Absence for thirty (30) or more cumulative days of absence in any given calendar year.

The parties agree to meet during the term of this collective agreement to discuss the point system and the quality of the garments to be purchased within 90 days of ratification.

Agreed to this 20<sup>th</sup> day of June, 2019.

FOR THE UNION

FOR THE CITY

"Dennis Champagne"

"Brent Cerenzia"

"Alfred D'Ettorre"

"Manny Sforza"

"Brad Miller"

"Nicole Maione"

"Brent

Lamming"

"Ida

Bruno

"

"Peter

Niro"

LETTER #TBD

LETTER OF UNDERSTANDING

BETWEEN

AMALGAMATED TRANSIT UNION LOCAL 1767

AND

THE CITY OF SAULT STE. MARIE

TIME OFF IN LIEU OF OVERTIME

Employees may request time off in lieu of overtime with the following conditions:

1. Maximum Time Off in Lieu – forty (40) hours lieu time once in a calendar year.
2. Time will be banked at straight time (ex. 1 hour of overtime will equal 1 hour in your lieu bank)



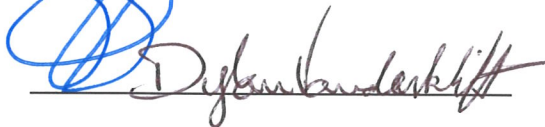
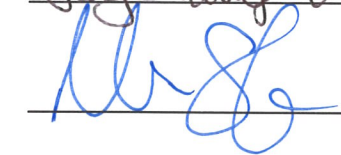

3. Requests for lieu time off will be considered on an individual basis at the time of request.
4. Requests for banked time will be made in writing at least 7 days in advance of the day/night shift requested.
5. Approval will be at the discretion of the Area Coordinator or Inspector or designate based upon the operational requirements of the Department.
6. Lieu time will not be used during lay-offs.
7. If not utilized, time will be paid out at straight time on the final pay period of the year.
8. Lieu time may not be granted from **July 1<sup>st</sup> to August 31<sup>th</sup>** in any given calendar year, based on workforce availability.

Agreed to this 8<sup>th</sup> day of June, 2023.

FOR ATU LOCAL 1767

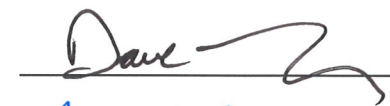
  
 \_\_\_\_\_  
  
 \_\_\_\_\_  
 Jay Vaughan  
 \_\_\_\_\_  
  
 \_\_\_\_\_

FOR CITY

  
 \_\_\_\_\_  
  
 \_\_\_\_\_  
  
 \_\_\_\_\_  
  
 \_\_\_\_\_  
  
 \_\_\_\_\_  
  
 \_\_\_\_\_

LETTER # TBD

LETTER OF UNDERSTANDING

BETWEEN

AMALGAMATED TRANSIT UNION LOCAL 1767

AND

THE CITY OF SAULT STE. MARIE

SHORTCHANGES

WHEREAS the Collective Agreement has included references to Shortchanges, which has been a long standing practice;

AND WHEREAS the Union has advised that they require a change to this practice before continuing to negotiate any further section of the Collective Agreement;

NOW THEREFORE the parties agree as follows:

1. A spareboard employee may not be entitled to the greatest piece of work (highest hours) and the City shall go to the next most senior person who has been free from work for at least 8 hours; They shall be assigned the first known full piece(s) of work after 8 hours free from work. If no full piece of work is available then partial pieces of work may be added together.
2. The Union and Employee agree that a driver won't be eligible for overtime if they have not been off for 8 consecutive hours in between days.
3. No grievances specifically related to spareboard work being assigned out of value order shall arise out of the implementation of this agreement from the Union.
4. This rest period does not apply to split shifts within the same day.
5. This LOU is without P&P and is no admission of liability.

DATED 8<sup>th</sup>, day of June, 2023.

FOR THE CITY

[Signature]  
Dave Z  
[Signature]  
BTL  
[Signature]  
Justin Palmer

FOR THE UNION

[Signature]  
Dylan Vandenberg  
Joy Vaughan  
[Signature]

SIGNED AT SAULT STE. MARIE this 8<sup>th</sup> day of June, 2023

FOR ATU LOCAL 1767

[Signature]  
Dylan Vandenberg  
Joy Vaughan

FOR CITY

[Signature]  
Dave Z  
Noble Attolino

Mr. [Signature]

But  
[Signature]  
Justin Palmer

**ORIGINAL LETTER:**

**LETTER #3**

**LETTER OF UNDERSTANDING**

**BETWEEN**

**AMALGAMATED TRANSIT UNION LOCAL 1767**

**AND**

**THE CITY OF SAULT STE. MARIE**

**JOINT CONSULTATION**

**COMMITTEE**

**TERMS AND CONDITIONS**

The City of Sault Ste. Marie and the Amalgamated Transit Union – Local 1767, agree to the following terms related to the provision of Article 5:07 of the collective agreement:

1. The Committee will consist of two (2) representatives of each party to deal with matters of mutual concern relating to the Transit operation.
2. Meetings will be scheduled as necessary on request of either party at a mutually agreed time and location. Such meetings will be scheduled during normal City business hours - 8:30 A.M. to 4:30 P.M., Monday through Friday."
3. Any member required to attend such meetings will suffer no lost pay.
4. Either party, or jointly if appropriate, shall prepare an agenda for distribution to all members of the Committee at least five working days in advance of the meeting. Minutes of the meeting will be prepared and distributed as determined by the Committee.
5. The Committee shall not deal with any matter that is the subject of a grievance or is more properly dealt with in the collective bargaining process.
6. The Committee shall not have the authority to alter or amend the Collective Agreement or make any decision inconsistent with its provisions.
7. The representatives agree to make every effort to resolve the issues in a cooperative manner.

Agreed to this 20<sup>th</sup> day of June, 2019.

FOR THE UNION

FOR THE CITY

"Dennis Champagne"

"Brad Miller"

"Brent Cerenzia"

"Nicole Maione"

"Alfred D'Ettorre"

"Brent Lamming"

"Manny Sforza"

"Ida

Bruno

"

"Pete

r

Niro"

Proposed Letter:

**LETTER #31**

**LETTER OF UNDERSTANDING**

**BETWEEN**

**AMALGAMATED TRANSIT UNION LOCAL 1767**

**AND**

**THE CITY OF SAULT STE. MARIE**

**JOINT CONSULTATION**

**LABOUR MANAGEMENT**

**COMMITTEE**





**TERMS AND CONDITIONS**

The City of Sault Ste. Marie and the Amalgamated Transit Union – Local 1767, agree to the following terms related to the provision of Article 5:07 of the collective agreement:





1. The **Union** Committee will consist of ~~two (2)~~ **three (3) union** representatives of ~~each party~~ to deal with matters of mutual concern relating to the Transit operations.
2. Meetings will be scheduled as necessary on request of either party at a mutually agreed time and location. Such meetings will be scheduled during normal City business hours - 8:30 A.M. to 4:30 P.M., Monday through Friday"
3. Any member required to attend such meetings will suffer no loss ~~st~~ pay **of** pay.
4. Either party, or jointly if appropriate, shall prepare an agenda for distribution to all members of the Committee at least five working days in advance of the meeting. Minutes of the meeting will be prepared and distributed as determined by the Committee.
5. The Committee shall not deal with any matter that is the subject of a grievance or is more properly dealt with in the collective bargaining process.
6. The Committee shall not have the authority to alter or amend the Collective Agreement or make any decision inconsistent with its provisions.
7. The representatives agree to make every effort to resolve the issues in a cooperative manner.

Agreed to this 6<sup>th</sup> day of April, 2023.

FOR THE UNION

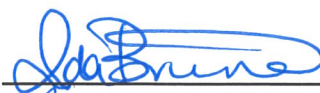
  
 \_\_\_\_\_  
  
 \_\_\_\_\_  
  
 \_\_\_\_\_  
  
 \_\_\_\_\_

FOR THE CITY

  
 \_\_\_\_\_  
  
 \_\_\_\_\_  
  
 \_\_\_\_\_  
  
 \_\_\_\_\_  
  
 \_\_\_\_\_

RENEW

LETTER #TBD (8)

LETTER OF UNDERSTANDING

BETWEEN

AMALGAMATED TRANSIT UNION LOCAL 1767

AND

THE CITY OF SAULT STE. MARIE



VIDEO SECURITY SURVEILLANCE CAMERAS

The City confirms the following general principles that are the guidelines that would be used with respect to the use of video security surveillance cameras at Transit:



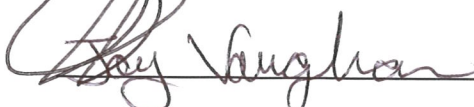

- Cameras are not used to monitor employee performance.
- Cameras will not be situated in areas where employee has a reasonable expectation of privacy e.g. change areas, wash rooms.
- Access to recorded information is restricted through the Director of Community Services and Director of Human Resources.
- Employees who are observed and recorded by video technology engaging in conduct that is in violation of City Policy/Procedures and/or law are advised that such information may be used by the City with respect to disciplinary action up to and including discharge.

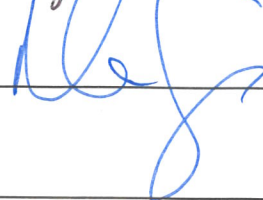
Agreed to this 26<sup>th</sup> day of April, 2023.

FOR ATU LOCAL 1767

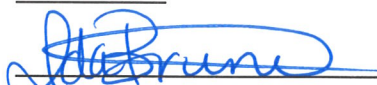
  
\_\_\_\_\_  
  
\_\_\_\_\_  
  
\_\_\_\_\_  
  
\_\_\_\_\_

FOR CITY

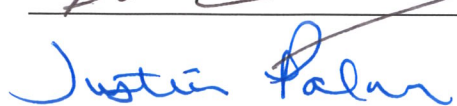
  
\_\_\_\_\_  
  
\_\_\_\_\_  
  
\_\_\_\_\_  
  
\_\_\_\_\_  
  
\_\_\_\_\_  
  
\_\_\_\_\_



**RENEW**

**LETTER #TBD (10)**

**LETTER OF UNDERSTANDING**

**BETWEEN**

**AMALGAMATED TRANSIT UNION LOCAL 1767**

**AND**

**THE CITY OF SAULT STE. MARIE**

**SPECIFIED PAID HOLIDAYS**

**ARTICLE 14: SPECIFIED PAID HOLIDAYS**

**14:04 Selection of Employees to Work on Specified Paid Holidays**

This procedure shall be effective for the term of this collective agreement only and shall be subject to renewal only by mutual agreement.

1. On the following reduced service holidays and any future reduced service holiday(s):
  - Family Day
  - Civic Holiday

The following procedures shall apply:

- A) The City shall determine the number of employees required to work on a paid holiday to meet the service levels that the City determines
- B) At the time of pick selection employees who wish to work on a specified paid holiday must select the corresponding box on the sign-up sheet
- C) The work on the specified paid holidays shall be offered in the following sequence to:

(i) Employees whose work assignments have such specified paid holiday as an ordinary working day. Such employees may request to work or not work on such specified paid holiday.

(ii) Employees by seniority from most senior to most junior from the sign-up list.

(iii) The employee with the work assignment under item (i) if there is any unfiled work remaining per item (ii).

D) Once a selection has been finalized and an employee has made a selection to work on a specified paid holiday, she/he cannot decide to work at a later date, cannot be bumped off the selection and cannot change the shift originally signed and selected.





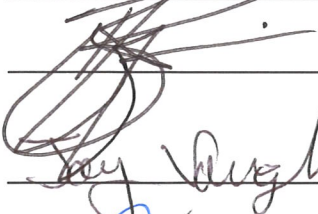
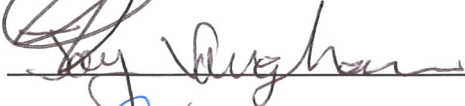
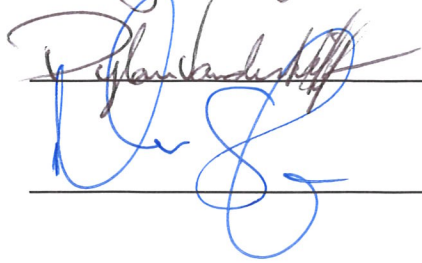
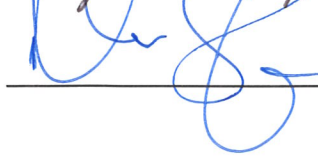

E) It is understood and agreed that Operators who pick a run under the terms of this letter are expected to work said Holiday. If not able to work said Holiday the Operator must request the time off or arrange for a trade.

Agreed to this 26<sup>th</sup> day of April, 2023.

FOR ATU LOCAL 1767

  
\_\_\_\_\_  
  
\_\_\_\_\_  
  
\_\_\_\_\_  
  
\_\_\_\_\_  
\_\_\_\_\_

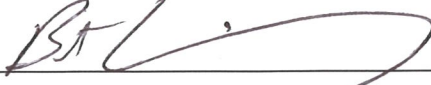
FOR CITY

  
\_\_\_\_\_  
  
\_\_\_\_\_  
  
\_\_\_\_\_  
  
\_\_\_\_\_  
  
\_\_\_\_\_  
  
\_\_\_\_\_

**RENEW**

**LETTER #13**

**LETTER OF UNDERSTANDING**

**BETWEEN**

**AMALGAMATED TRANSIT UNION LOCAL 1767**

**AND**

**THE CITY OF SAULT STE. MARIE**

**USE OF VACATION FLOATER DAYS**

It is agreed and understood that Operators with Floating Vacation Days remaining to be booked after the regular booking period referred to in Article 15, may use such days the following year, to cover days where an Operator is ill provided the following:

1. The City reserves the right to ask for a medical note verifying the reason for absence (illness) in accordance with Article 16:04.
2. The employee/operator must declare that the floating vacation day is being requested for illness absence within 24 hours of the call in.
3. This letter will be in effect for a trial period of two (2) years beginning January 1, 2016.
4. This letter is subject to renewal by mutual agreement of the parties.

Agreed to this 20<sup>th</sup> day of June, 2019.

FOR THE UNION

FOR THE CITY

"Dennis Champagne"  
"Brent Cerenzia"

"Brad Miller"  
"Nicole Maione"

"Alfred D'Ettorre"  
"Manny Sforza"

"Brent Lamming"  
"Ida Bruno"  
"Peter N"

**PROPOSED**

**LETTER #13**

**LETTER OF UNDERSTANDING**

**BETWEEN**

**AMALGAMATED TRANSIT UNION LOCAL 1767**

**AND**

**THE CITY OF SAULT STE. MARIE**

**USE OF VACATION FLOATER DAYS**

It is agreed and understood that Operators with Floating Vacation Days remaining to be booked after the regular booking period referred to in Article 15, may use such days the following year, to cover days where an Operator is ill provided the following:

5. The City reserves the right to ask for a medical note verifying the reason for absence (illness) in accordance with Article 16:04.
6. The employee/operator must declare that the floating vacation day is being requested for illness absence within 24 hours of the call in.
7. This letter will be in effect for a trial period of two (2) years beginning January 1, 2016.
8. This letter is subject to renewal by mutual agreement of the parties.

Agreed to this 20<sup>th</sup> day of June, 2019.

FOR THE UNION

FOR THE CITY

"Dennis Champagne"  
"Brent Cerenzia"  
"Alfred D'Ettorre"  
"Manny Sforza"

"Brad Miller"  
"Nicole Maione"  
"Brent Lamming"  
"Ida Bruno"  
"Peter N"

Agreed to this 25<sup>th</sup> day of April, 2023.

FOR ATU LOCAL 1767

FOR CITY

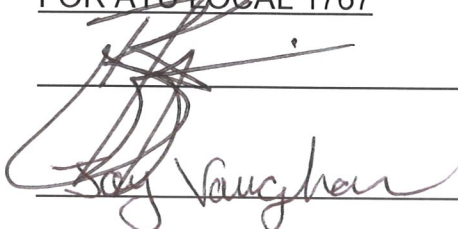
  
\_\_\_\_\_  
Ray Vaughan  
\_\_\_\_\_  
Dennis Champagne  
\_\_\_\_\_  
Al S  
\_\_\_\_\_  
\_\_\_\_\_

  
\_\_\_\_\_  
Nicole Maione  
\_\_\_\_\_  
Murray  
\_\_\_\_\_  
Dave  
\_\_\_\_\_  
BT  
\_\_\_\_\_  
Justin Palmer

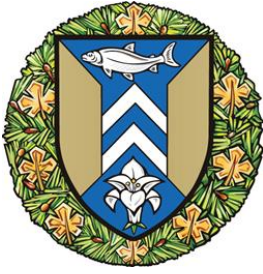

**The Corporation of the  
City of Sault Ste. Marie**

**C O U N C I L   R E P O R T**

June 19, 2023

TO: Mayor Matthew Shoemaker and Members of City Council  
AUTHOR: Tom Vair, Deputy CAO, Community Development and  
Enterprise Services  
DEPARTMENT: Community Development and Enterprise Services  
RE: Mill Market Lease

---

**Purpose**

The purpose of this report is to seek Council approval to enter into a lease agreement with Mill Market Sault Ste. Marie (Mill Market) for the building at 73 Brock Street and the mobile retail units located within the downtown plaza.

**Background**

On March 23, 2020 City Council approved the acquisition of 73 Brock Street with the purpose of hosting the Mill Market. On February 21, 2023, City Council passed a resolution authorizing the project budget to complete the renovations of the Mill Market.

The renovation project is advancing and staff have worked with Mill Market Board members to develop a lease agreement for the building at 73 Brock Street and the mobile retail units to be located in the downtown plaza. The lease term for the building is twenty five (25) years with the option for up to two (2) additional 5-year terms upon the same terms and conditions.

The rental fee is \$1 per year (similar to the current location at the former fish hatchery building located at 35 Canal Drive). The Mill Market will be responsible for all utilities of the building and managing operations of both the market and mobile retail units. The building will be made available for other community events and meetings during non-market hours.

Given the mobile retail units are a new offering, the lease term for these units is for two (2) years, which may be extended for up to two periods of five (5) years after successful negotiations between the City and Mill Market.

The Mill Market has been successful in obtaining \$1,961,596 in funding (\$250,000 - Provincial RED program; \$1,711,596 Federal GICB program) to date and has an

Mill Market Lease

June 19, 2023

Page 2.

application pending with NOHFC for further funding. The Mill Market is also contributing \$40,000 from their reserves towards the project.

### **Analysis**

Finalizing the lease agreement with the Mill Market represents the next step in the process that began in 2020 to relocate the Mill Market to 73 Brock Street.

The relocation of the Mill Market is an important component of the downtown revitalization strategy. The building at 73 Brock Street was purchased with the intent of relocating the market as this site creates a number of positive synergies with the downtown plaza and future events and programming.

Having the Mill Market operate the mobile retail units is beneficial as the Mill Market maintains relations with vendors and can coordinate operations of the mobile retail units to complement the market. The mobile retail units are located immediately behind 73 Brock Street within the downtown plaza.

### **Financial Implications**

The lease will see the Mill Market pay \$1 per year in rent and the Mill Market will cover all utilities and operational costs for 73 Brock Street and the management and oversight of the market and mobile retail units. The City has already allocated funds to cover its share of the leasehold improvements to the building and no new funds are being requested of the City at this time.

### **Strategic Plan / Policy Impact / Climate Impact**

The Mill Market project aligns directly with several areas of the Corporate Strategic Plan including: Quality of Life – Vibrant Downtown Areas – We are striving to create a vibrant downtown that contributes to the vitality and resiliency of our City. Downtown areas play a central role in defining the character of our City.

And also, “Promote and Support Arts and Culture.” Community Development and Partnerships – Develop partnerships with key stakeholders.

### **Recommendation**

It is therefore recommended that Council take the following action:

The relevant By-law 2023-94 is listed under item 12 of the Agenda and will be read with all by-laws under that item.

Respectfully submitted,

Tom Vair  
Deputy CAO  
Community Development & Enterprise Services  
(705)759-5264  
[t.vair@cityssm.on.ca](mailto:t.vair@cityssm.on.ca)

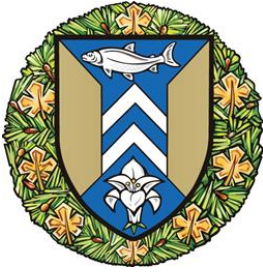

**The Corporation of the  
City of Sault Ste. Marie**

**COUNCIL REPORT**

June 19, 2023

TO: Mayor Matthew Shoemaker and Members of City Council

AUTHOR: Travis Anderson, Director Tourism and Community  
Development

DEPARTMENT: Community Development and Enterprise Services

RE: Delegated Authority for Tourism Development Fund  
Agreements

---

**Purpose**

The purpose of this report is to seek Council approval of delegated authority related to the approval of standardized Tourism Development Fund agreements.

**Background**

The Tourism Development Fund (TDF) was initiated on June 1, 2021 to provide financial support to the local tourism sector for festivals and special events and attractions and product development. The funding for both streams of the TDF is generated through the collection of the Municipal Accommodation Tax (MAT).

The Product Development Stream provides support for upgrades to, or the creation of new infrastructure, business or products that will create quantifiable improvements to the tourism offerings in Sault Ste. Marie. Applicants can apply for up to \$50,000 under this stream. In cases where the product has the potential for significant, positive impact on tourism visitation, consideration for a higher level of funding may be given.

The Festivals and Events stream of the TDF supports new and existing events that attract new visitors to the community and/or inspire current visitors to stay longer in the community. Applicants may apply once per fiscal year under this stream, up to a maximum of \$20,000. In special circumstances where the event may have a significant impact on tourism visitation to Sault Ste. Marie, consideration for higher levels of funding may be given.

Upon receipt of a TDF application, staff review the application for eligibility and score the application based on an evaluation matrix. The applications are brought to the Tourism Sault Ste. Marie Board of Directors for further discussion and evaluation. Should the Board endorse the application, they are then brought



forward to Council for final approval. The entire process takes on average ninety days.

Staff is proposing to streamline the approval process Tourism Development Fund grant agreements, by requesting delegation of authority to approve and sign the standardized TDF agreement with funding applicants. The standardized TDF agreement has been approved by Legal and is Schedule "A" to By-law 2023-101 that is before Council for consideration.

### **Analysis**

The Tourism Development Fund is continuing to see a steady increase in project applications. To date a total of thirty-three projects have received funding through the TDF, with an increasing number of applications received on a monthly basis.

Of the applications received, only six applications met or exceeded \$50,000 with the majority of the applications in the range of \$2,500 - \$15,000. From the time an application is received by staff to the point it is approved by Council, the process takes approximately 90 days. Staff are looking to reduce timelines and make the process more efficient by seeking delegation of authority to enter into standardized contracts for the TDF. Specifically, staff are seeking the following delegation of authority:

- Ability to enter into agreements that directly bind the Corporation that are limited to:
  - Standard TDF approved agreements that have been reviewed and approved by the City Legal department.

The delegation of authority is requested for the CAO, Deputy CAO of Community Development and Enterprise Services and the Director of Tourism and Community Development with the ability to approve TDF applications to a dollar value consistent with that set out in the City's Procurement Policies and Procedures document and detailed below:

- Director of Tourism and Community Development – Approval up to \$10,000
- Deputy CAO, Community Development and Enterprise Services – Approval up to \$30,000
- CAO – Approval limit of CAO up to \$125,000

This delegation of authority allows these positions to directly approve standardized TDF agreements and will ensure a more efficient and timely approval process to meet the standards of applicants, tourism partners and service providers.

The Tourism Sault Ste. Marie Board will still review and provide recommendations on all applications and a summary report will be provided to Council annually with the projects supported by the Tourism Development Fund.

### **Financial Implications**

There is no financial impact associated with this report.

**Strategic Plan / Policy Impact / Climate Impact**

Eliminating barriers to business and streamlining process - Streamlining process improves the relationship with individual and corporate citizens. Addressing barriers that may impede success and fostering a culture that encourages innovative solutions will result in enhanced service delivery.

There are no climate change impacts because of this report.

**Recommendation**

It is therefore recommended that Council take the following action:

The relevant By-law 2023-101 is listed under item 12 of the Agenda and will be read with all by-laws under that item.

Respectfully submitted,

Travis Anderson  
Director, Tourism & Community Development  
705.989.7915  
[t.anderson@cityssm.on.ca](mailto:t.anderson@cityssm.on.ca)

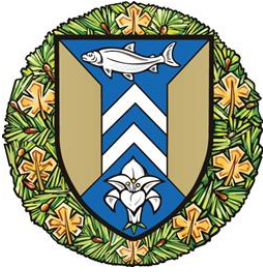

The Corporation of the  
City of Sault Ste. Marie  
**COUNCIL REPORT**

June 19, 2023

TO: Mayor Matthew Shoemaker and Members of City Council  
AUTHOR: Travis Anderson, Director Tourism and Community  
Development  
DEPARTMENT: Community Development and Enterprise Services  
RE: Long-term Funding Requirements – Entomica Insectarium

---

**Purpose**

The purpose of this report is to provide Council with an overview of the funding requirements needed to support the long-term financial stability of Entomica Insectarium (Entomica).

**Background**

On August 8, 2022 Council passed the following resolution:

Whereas Entomica has become a valued community partner, educational activity and tourism asset; and

Whereas Entomica is active within the community through school events, virtual teaching, partnerships and outreach; and

Whereas many families, community members and tourists enjoy visiting Entomica; and

Whereas Entomica needs consistent and stable funding on an annualized basis to continue its operation;

Now Therefore Be It Resolved that staff be directed to work with Entomica to determine the level of funding it requires and then to assess how the municipality can contribute to ensuring Entomica has a stable and long-term future in our community and to return funding options back to Council for its 2023 budget deliberations which funding options shall specifically include both levy and non-levy impacts.

Staff from Tourism and Community Development and Millworks met with Entomica to understand the financial requirements to ensure the long-term sustainability of the organization.

## **Analysis**

### **Overview of Organization:**

Entomica, a not-for-profit charitable organization, is an insect-focused science centre and natural history museum, located in the Canadian Bushplane Heritage Centre (Bushplane).

Founded in 2014, Entomica's mission is to inspire and connect visitors of all ages with science and nature through education and community outreach programs, events, and interactive experiences. The organization promotes tourism, education appreciation, conservation, and preservation of biodiversity.

Entomica is one of four insectariums in Canada, and the first Federally approved to move exotic insects outside of their secure location. As such, they can bring their unique insects out into the community and deliver interactive, hands-on program at schools, retirement residences, community events, fundraisers, etc. Entomica estimates that between its facility at the Bushplane, events and community outreach, it engages approximately 65,000 individuals annually.

As an organization, Entomica is valued and has been recognized for its work on a local, provincial, and national level, winning awards for program delivery and contributions to the tourism industry. However, despite its many accolades, Entomica struggles to achieve financial stability and has regularly been at risk of closing.

### Financial Constraints:

At present, Entomica has several streams of revenue to fund its operation including:

- Outreach programming to school boards and retirement/nursing homes,
- Special events:
- Grants and donations:
- Merchandise sales; and
- As of March 2023, revenue from admission at the Bushplane.

Despite having multiple revenue sources, the organization operates at or close to a deficit on an annual basis. There are numerous challenges obstructing its long-term financial stability. These challenges include:

- Long-term financial impacts due to loss of revenue due to the pandemic;
- High-operating/staffing costs to maintain the exhibits and insects; and
- Lack of full-time permanent staff, resulting in increased training costs and insufficient staffing resources to support outreach and operating commitments to the Bushplane.

Entomica has attempted to address its financial shortfalls by applying for numerous grants. However, the grants are typically short-term in nature, providing only temporary relief. Given the delays in confirming financial information and ongoing

discussions with the Bushplane on revenue sharing options, staff were not able to bring a report for the 2023 budget.

Staff worked with Entomica to prepare an application to Tourism Sault Ste. Marie (TSSM) to assist with 2023 operations. TSSM granted Entomica \$75,000 to assist with operating costs and the hiring of one full-time manager for 2023. Despite the generous donation from TSSM, Entomica's long-term financial sustainability remains a concern.

As an organization, Entomica needs long-term consistent revenue that will allow the organization to hire and maintain full-time staff. Full-time staff would provide the necessary bandwidth to optimize various revenue streams, including those mentioned above, as well potential new sources.

As part of the assessment, staff requested a current financial statement, along with financial projections detailing what revenue would be needed by the organization to ensure financial stability. Based on the documents supplied, as well as Entomica's own assessment, it is estimated that approximately \$137, 276 in new money is required for the organization to become financially stable.

The bulk of funding requirements can be attributed to staffing levels proposed by Entomica, which propose four full-time staff to meet their obligations to the Bushplane while also pursuing other sources of revenue.

#### **Staff Recommendations:**

Following the review of the financial statements staff met with Entomica to discuss opportunities to reduce expenses and/or increase revenue streams. These recommendations are detailed below:

1. Reduced operating hours at Bushplane: Under the current Memorandum of Understanding (MOU) Entomica is required to maintain the same operating days/hours as the Bushplane (6 days per week in summer, 5 days/week in winter). However, due to lack of staff and scheduling conflicts associated with outreach opportunities, Entomica is not able to consistently meet its obligations under the MOU. In conversation with the senior Bushplane staff and Chair of its Board, staff were advised that the Bushplane would entertain allowing Entomica to reduce their operating hours.

City staff recommended that Entomica consider reducing the number of days they operate in the Bushplane and limiting activities on the days they do not operate to strictly caring for insects and necessary administrative tasks. By taking these actions, Entomica would reduce its staffing requirements, thereby reducing its operating costs. Entomica did not feel that the recommendation was practical as a staff member would be required to feed and clean the various displays and would be at the facility regardless of whether it were open.

2. Leveraging Entomica's charitable status and corporate donations: Staff also recommended that Entomica leverage their charitable status by conducting

- a fund-raising campaign to increase potential revenue for the organization. Entomica could leverage its upcoming 10-year anniversary (June 2024) to draw attention to the organization and galvanize community and corporate support for the organization. Due to a lack of staff resources, the organization felt that they did not have sufficient resources to conduct a large fund-raising campaign.
3. Partnership: Finally, staff suggested that Entomica consider collaborating with another organization, such as the Bushplane or Science North, to provide staffing and financial support. Under this recommendation, Entomica would have reduced control over their operation and act in advisory role or on the Board of Directors of the organization. This recommendation was not viewed as palatable by the organization as it meant a reduced role in the day-to-day operations of Entomica.

Ultimately, Entomica decided that it would like to pursue annual funding from the municipality of \$137,276.

### **Financial Implications**

Should Council approve long-term operational funding for Entomica, there would be an increase of \$137,276 to the City's annual budget. This matter would be deferred to 2024 budget deliberations.

### **Strategic Plan / Policy Impact / Climate Impact**

This item supports the Corporate Strategic Plans Focus Area:

- Community Development and Partnership focus of Maximizing Economic Development and Investment with the commitment to maintain financial viability.
- Community Development – Develop partnerships with key stakeholders and reconciliation

There are no climate change or GHG emission implications associated with this report.

### **Recommendation**

It is therefore recommended that Council take the following action:

Resolved that the report of the Director Tourism and Community Development dated June 19, 2023 be received and that Council refer Entomica's request for \$137,276 in annual funding to 2024 budget deliberations.

Long-term Funding Requirements – Entomica Insectarium

June 19, 2023

Page 5.

Respectfully submitted,

Travis Anderson

Director, Tourism and

Community Development

705.989.7915

[t.anderson@cityssm.on.ca](mailto:t.anderson@cityssm.on.ca)

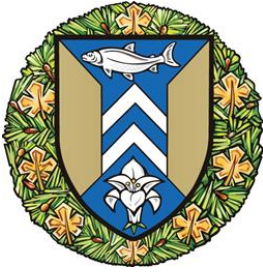

**The Corporation of the  
City of Sault Ste. Marie**

**COUNCIL REPORT**

June 19, 2023

TO: Mayor Matthew Shoemaker and Members of City Council  
AUTHOR: Virginia McLeod, Manager of Recreation and Culture  
DEPARTMENT: Community Development and Enterprise Services  
RE: Request to Rename Snowdon Park

---

**Purpose**

This report has been prepared to provide a recommendation to City Council in response to the request from the Children of Shingwauk to rename Snowdon Park to Memorial Park.

**Background**

At the January 9, 2023 City Council meeting, Council received correspondence on behalf of the Children of Shingwauk Alumni Association and Ken Crossman requesting to change the name of Snowdon to Memorial Park. Council passed the following resolution:

Resolved that the request of the Children of Shingwauk to rename Snowdon Park as Memorial Park be referred to the Parks and Recreation Advisory Committee for review and recommendation to Council.

The matter was referred to the Parks and Recreation Advisory Committee (PRAC) for review and recommendation. PRAC met on March 7, 2023 and passed the following resolution:

Resolved that the Parks and Recreation and Advisory Committee appoint Brenna Tomas and Deane Greenwood to participate in a task force with Director of Community Services, Manager of Recreation and Culture, Manager of Parks, Supervisor of Recreation to review the request to rename Snowdon Park and report back to the Parks and Recreation Advisory Committee.

CARRIED

The Snowdon Park Renaming Task Force met on March 24, 2023 to review background information and correspondence from Children of Shingwauk Alumni Association (CSAA) and the family of Ashton Snowdon. The task force recommended that a meeting be scheduled and include members of the CSAA Snowdon Park Memorial Committee and family members of Ashton Snowdon.



April 24, 2023 the task force met with CSAA, Ken Crossman and descendants of Ashton Snowdon to discuss the renaming of the park. Both parties came to the same conclusion at the meeting. The name Snowdon Park would remain to honour the contributions Ashton Snowdon made to the community. An area of the park will be renamed to remember those who lost their lives in the former pond and the CSAA will finalize a name at their next meeting.

The Snowdon Park Renaming task force provided the Parks and Recreation Advisory Committee an update and recommendation at their May 9, 2023 meeting and passed the following resolution:

Resolved that the Parks and Recreation Advisory Committee recommend to City Council that Snowdon Park name remain and that an area in the northwest corner of the park is dedicated as a memorial; and  
Further that the Children of Shingwauk Alumni Association - Snowdon Park Memorial Group work with City Staff to finalize the name for the memorial space and a sign be erected.

CARRIED

The Children of Shingwauk Alumni Association Snowdon Park Memorial Committee met on May 17, 2023. The name for the memorial area was finalized at the meeting and the committee is requesting that the area be called "Every Child Matters Sacred Memorial."

### **Analysis**

The meeting provided an opportunity to meet one another and share the history of the park and its meaning to those involved. Both parties came to the meeting with similar conclusions on the course of action for naming of the park.

The Children of Shingwauk Alumni Association agreed that the park name should remain Snowdon Park. An area in the northwest corner of the park has three benches and three trees planted which will have commemorative plaques installed on tree guards. In addition, a large rock located in the middle of the benches will share the history of the park. A pathway will be developed and an arbour will welcome visitors to the memorial, a sign will be installed which reads "Every Child Matters Sacred Memorial." A map of the area is included as appendix A.

### **Financial Implications**

There are no financial implications related to this report.

### **Strategic Plan / Policy Impact / Climate Impact**

This subject is not a matter articulated in the Strategic Plan.

Request to Rename Snowdon Park

June 19, 2023

Page 3.

**Recommendation**

It is therefore recommended that Council take the following action:

Resolved that the report of the Manager of Recreation and Culture dated June 19, 2023 concerning Request to Rename Snowdon Park be received and the recommendation of the Parks and Recreation Advisory Committee that the Snowdon Park name remain and a memorial area in the northwest of the park be named "Every Child Matters Sacred Memorial" be approved.

Respectfully submitted,

Virginia McLeod

Manager of Recreation and Culture

705.759-5311

[v.mcleod@cityssm.on.ca](mailto:v.mcleod@cityssm.on.ca)

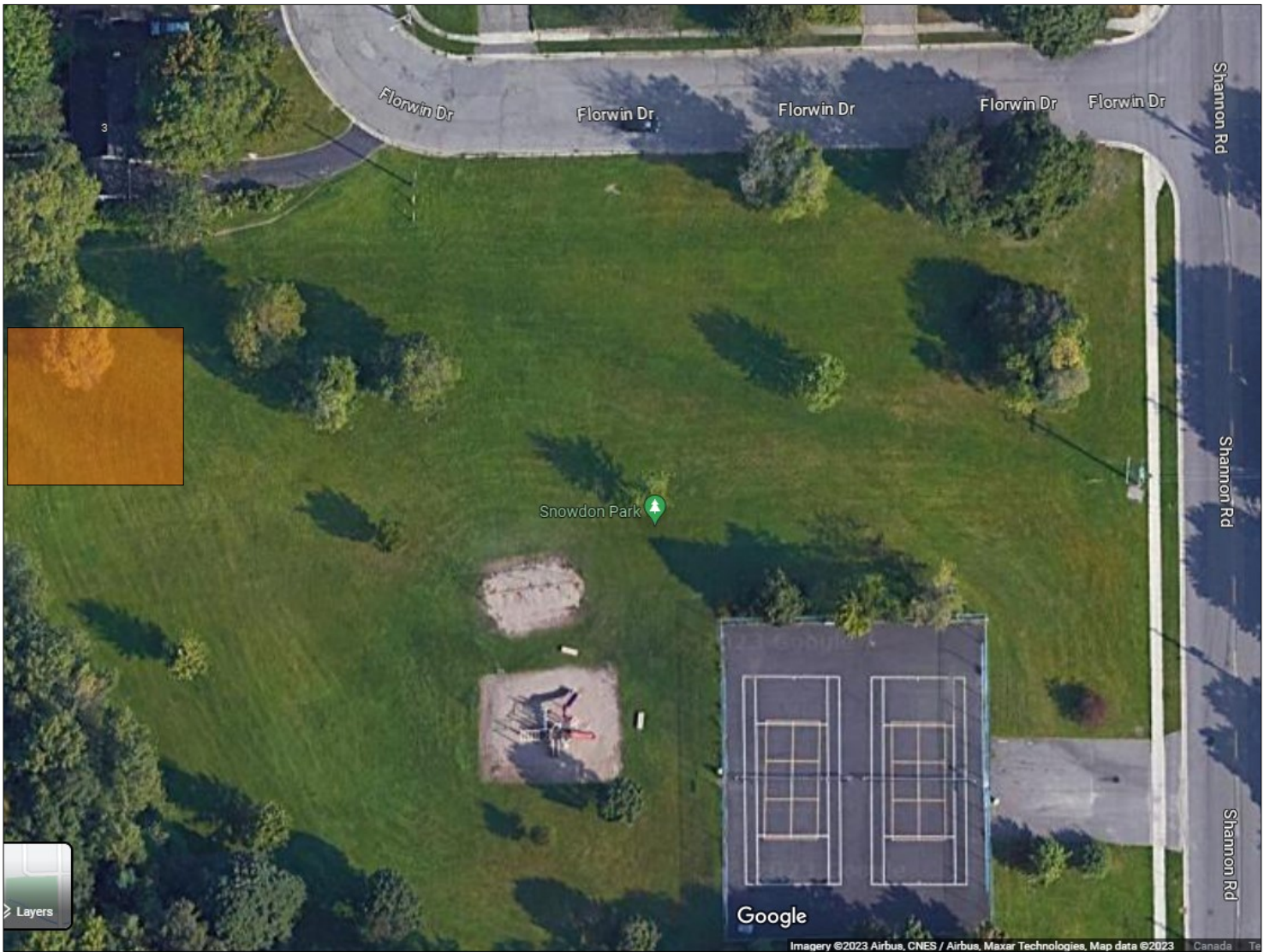

The area shaded orange is the location of the memorial and the Children of Shingwauk Alumni Association and Ken Crossman have asked that it be referred to as :

“Every Child Matters Sacred Memorial”

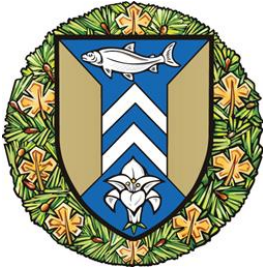

**The Corporation of the  
City of Sault Ste. Marie**

**C O U N C I L   R E P O R T**

June 19, 2023

TO: Mayor Matthew Shoemaker and Members of City Council  
AUTHOR: Virginia McLeod, Manager of Recreation and Culture  
DEPARTMENT: Community Development and Enterprise Services  
RE: Sault Ste. Marie Museum Window Project Agreement

---

**Purpose**

The purpose of this report is to request approval from City Council to enter into an agreement with the Sault Ste. Marie and 49<sup>th</sup> Field Regiments RCA Historical Society.

**Background**

The Sault Ste. Marie Museum building, located at 690 Queen Street is owned by the City of Sault Ste. Marie. As owner of the property, the City is responsible for the capital repairs. The daily operations of the Sault Ste. Marie Museum are the responsibility of the Sault Ste. Marie 49<sup>th</sup> Field Regiment RCA Historical Society. Sault Ste. Marie and 49<sup>th</sup> Field Regiments RCA Historical Society applied for a Canada Cultural Spaces grant to assist with the replacement of windows at the Sault Ste. Marie Museum.

**Analysis**

The Sault Ste. Marie Museum was successful and received a grant for \$96,461 to support the replacement of windows. The City of Sault Ste. Marie has \$208,542 allocated towards this project. The grant funding will allow additional windows to be replaced.

**Financial Implications**

The City has allocated \$208,542 to support the replacement of windows at the Sault Ste. Marie Museum the additional \$96,461 in funding received by the Sault Ste. Marie Museum will support the project.

**Strategic Plan / Policy Impact / Climate Impact**

This matter is not articulated in the Strategic Plan.

**Recommendation**

It is therefore recommended that Council take the following action:

The relevant By-law 2023-106 is listed under Agenda item 12 and will be read with all by-laws under that item.

Sault Ste. Marie Museum Window Project – Agreement

June 19, 2023

Page 2.

Respectfully submitted,

Virginia McLeod

Manager of Recreation and Culture

705.759-5311

[v.mcleod@cityssm.on.ca](mailto:v.mcleod@cityssm.on.ca)

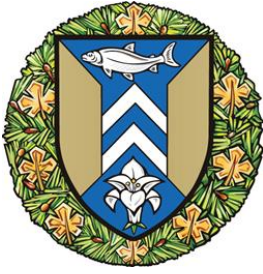

**The Corporation of the  
City of Sault Ste. Marie**

**C O U N C I L   R E P O R T**

June 19, 2023

TO: Mayor Matthew Shoemaker and Members of City Council  
AUTHOR: Emily Cormier, Sustainability Coordinator  
DEPARTMENT: Community Development and Enterprise Services  
RE: Community Development Fund – Green Initiatives Program  
Applications June 2023

---

**Purpose**

The purpose of this report is to seek Council approval for recommendations from the Environmental Sustainability Committee for the distribution of Community Development Fund (CDF) – Green Initiatives Program funds.

**Background**

The purpose of the Green Initiatives Program of the Community Development Fund (CDF) is to support green initiatives that result in reduced greenhouse gas emissions (GHGs), improve water quality/rehabilitation, increase energy efficiency, healthy and resilient ecosystems, including habitat restoration, active transportation and waste reduction. The City of Sault Ste. Marie's (the City) Environmental Sustainability Committee (ESC) is responsible for making recommendations for the allocation of funds for eligible projects or programs that support the City's environmental plans and practices.

Funding applications are reviewed by the ESC in accordance with the CDF – Green Initiatives Program guidelines and are accepted on a rolling intake throughout the year. Total annual funds available for all projects under the CDF – Green Initiatives Program in 2023 is \$50,000. Eligible applicants include not-for-profit organizations and City departments.

Three projects were presented to the ESC on June 6, 2023. The committee passed the following resolutions:

Resolved that the Environmental Sustainability Committee supports the request for funding from the CDF Green Initiatives Program in the amount of \$1,750 for the City of Sault Ste. Marie Tourism Department "Clear Your Gear" project funding request and recommends that Council approve the request.

Resolved that the Environmental Sustainability Committee supports the request for funding from the CDF Green Initiatives Program in the amount of \$16,050 for the City of Sault Ste. Marie Community Development and Enterprise Services Civic Centre electric vehicle charging project funding request and recommends that Council approve the request.

Resolved that the Environmental Sustainability Committee supports the request for funding from the CDF Green Initiatives Program in the amount of \$6,975.62 for the Sault Ste. Marie Innovation Centre “Trapping the Flow” funding request and recommends that Council approve the request.

### **Analysis**

#### **City of Sault Ste. Marie Tourism Department Clear Your Gear Project Funding Request**

The City of Sault Ste. Marie Tourism Department is seeking to support Parks Canada by installing seven Clear Your Gear fishing line recycling receptacles on Canal property and Whitefish Island National Historic sites to provide a safe, environmentally friendly way to collect and recycle discarded fishing line in high impact fishing areas.

*Clear Your Gear* is a Canadian company specializing in fishing line receptacles<sup>1</sup>. Improperly discarded fishing line can last in the environment up to 600 years and is the leading cause of entanglement issues for people, property and wildlife. By providing convenient and accessible locations for used/discarded fishing line to be properly disposed of the river will experience reduced amounts of ghost line in the waterways and shoreline. This will result in the protection of wildlife and habitats in the area and, with the waste line being recycled, keep the plastic from entering the City landfill. Clear Your Gear recycles fishing line materials to create fish habitats. This project aligns with improve water quality, healthy and resilient ecosystems and waste reduction pillars of the green initiatives fund.

#### **City of Sault Ste. Marie Community Development and Enterprise Services Civic Centre Electric Vehicle Charging Project Funding Request**

Sault Ste. Marie Community Development and Enterprise Services is seeking to initiate the installation of electric vehicle charging infrastructure for the City’s light duty fleet. The project would install two, single head, Level 2 electric vehicle chargers at the Civic Centre (99 Foster Drive) South parking lot near the engineering fleet nearest to the St. Mary’s River and on the west side of the parking lot.

Total charger cost is estimated to be \$25,200. The chargers are eligible for a \$10,000 rebate (\$5,000 each) through the Natural Resources Canada (NRCan)

---

<sup>1</sup> <https://clearyourgear.ca/>

Zero Emission Vehicle Infrastructure Program program. The PUC will apply on the City's behalf for this incentive and will pay for the total project costs up front and bill the City for a maximum of \$15,200 due to the rebate. Consultation with City building services has also determined the need for a 16' long x 6' high fence with alternative 1x6 fence boards to be built to protect the charger from snow drifts during the winter. The cost that City carpentry estimates for materials is \$850.

It is anticipated that this project will help drive momentum forward on the City's light duty fleet emissions reduction efforts by offering an understanding of costs associated to installing charging infrastructure, which will support future City budgets. This project aligns with the GHG reduction pillar of the Green Initiatives Fund. It also aligns with the City Council 2021 resolution that mandated EV replacement on a go-forward basis as current light duty vehicles reach end of life.

### **Sault Ste. Marie Innovation Centre Trapping the Flow Project Funding Request**

The Sault Ste. Marie Innovation Centre – Lake Huron North Trapping the Flow project is a pilot initiative that seeks to install eight LittaTrap filters in stormwater drains at the intersection of Bay and East Street near the James L. McIntyre Centennial Library. LittaTraps are a modular catch basin filter designed for placement inside any catch basin structure to prevent litter, microplastics and other debris carried by stormwater from entering the storm drain system<sup>2</sup>.

The project seeks to raise awareness about plastic pollution in the Great Lakes and the City's efforts to address the issue of plastic pollution. The project will also involve a partnership with the Sault Ste. Marie Public Library by creating an educational sign about how the LittaTraps work, as well as participating in the Libraries Loves Lakes project to create a display of books about lakes when once the LittaTraps are installed.

Consultations with the City's Area Coordinator Wastewater have taken place and members of the City's Public Works team will install and empty the LittaTraps as part of the project. The SSMIC will work with the City to assess and measure debris collected in the LittaTraps to evaluate effectiveness of the project and prepare for possible expansion on future City stormwater drains. This project aligns with improve water quality, healthy and resilient ecosystems and waste reduction pillars of the green initiatives fund.

### **Financial Implications**

The 2023 Community Development Fund – Green Initiatives Fund currently has an uncommitted balance of \$25,014.73 available to support the three projects in this report totalling \$24,775.62.

---

<sup>2</sup> <https://www.enviropod.com/en-ca>



**Strategic Plan / Policy Impact / Climate Impact**

The project recommendations support the values and focus areas of the Community Strategic Plan for 2021 – 2024 through:

- **Environmental Stewardship:** We will use resources wisely to maintain and create a sustainable city for future generations

In addition, the applications support actions under the transportation, waste reduction and green space pillars of the Sault Ste. Marie Community GHG Reduction Plan: 2020 – 2030 including:

- Supporting fleet electrification opportunities, including charging infrastructure
- Environmental stewardship
- Waste diversion and education

**Recommendation**

It is therefore recommended that Council take the following action:

Resolved that the report of the Sustainability Coordinator dated June 6, 2023 concerning Community Development Fund – Green Initiatives Program Applications June 2023 be received and that the recommendations of the Environmental Sustainability Committee to support the following be approved:

1. City of Sault Ste. Marie Tourism Department “Clear Your Gear” project funding in the amount of \$1,750;
2. City of Sault Ste. Marie Community Development and Enterprise Services Civic Centre Electric Vehicle Charging project funding in the amount of \$16,050; and,
3. Sault Ste. Marie Innovation Centre Trapping the Flow project funding in the amount of \$6,975.62

Respectfully submitted,

Emily Cormier  
Sustainability Coordinator  
705.989.8748  
[e.cormier2@cityssm.on.ca](mailto:e.cormier2@cityssm.on.ca)

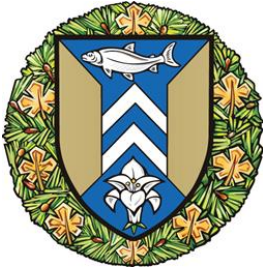

The Corporation of the  
City of Sault Ste. Marie

## COUNCIL REPORT

June 19, 2023

TO: Mayor Matthew Shoemaker and Members of City Council  
AUTHOR: Susan Hamilton Beach, P. Eng.  
DEPARTMENT: Public Works and Engineering Services  
RE: Curb and Sidewalk Program 2023

---

### **Purpose**

The purpose of this report is to inform Council of the proposed 2023 Curb and Sidewalk Program.

### **Background**

Each year the program is reported to Council for information. This year, it is proposed that the program include approximately 1446 square metres of sidewalk, 341 linear metres of curb and 10 accessibility ramps to improve curbs and sidewalks. Attached is the listing of the 2023 locations. The program represents approximately 0.1% of the curb inventory and 0.3% of the sidewalks maintained by the City. The budget for this program is \$517,425.

### **Analysis**

Typically, the program is compiled from requests from Councillors, residents and staff each year. Budgetary constraints allow for a limited amount of work to be undertaken each year. It is necessary to prioritize the requests and normally not all requests can be accommodated.

### **Financial Implications**

The proposed program maximizes the assigned operational budget for curb and sidewalk program.

### **Strategic Plan / Policy Impact / Climate Impact**

The sidewalk and curb repair program is linked to the Asset Management, Maintaining Existing Infrastructure component of the Corporate Strategic Plan.

### **Recommendation**

It is therefore recommended that Council take the following action:

Resolved that the report of the Director of Public Works dated June 19, 2023 concerning the 2023 Curb and Sidewalk Program be received as information.

Curb and Sidewalk Program 2023

June 19, 2023

Page 2.

Respectfully submitted,

A handwritten signature in blue ink, appearing to read "Susan Beach". The signature is fluid and cursive, with the first name "Susan" and the last name "Beach" clearly distinguishable.

Susan Hamilton Beach, P. Eng.

Director of Public Works

705.759.5207

[s.hamiltonbeach@cityssm.on.ca](mailto:s.hamiltonbeach@cityssm.on.ca)

# Curb And Sidewalk Program 2023

PROGRAM TOTALS	
Curb	341 Linear Metres
Sidewalk	1446 Square Metres
Accessibility Ramps	10 Highlighted in red

Civic Address	Street Name	Accessibility Ramp (W/C Ramp)
388	Albert Street West	
20	Ascot Avenue	
155	Asquith Street	
56	Bainbridge Street	
40	Bainbridge Street	
3	Bainbridge Street	
55	Beaumont Avenue	
123	Bellevue Avenue	W/C Ramp
123	Bellevue Avenue	
224	Bennett Boulevard	
330	Beverley Street	
886	Bonney Street	
31	Borron Avenue	
342	Boundary Road	
364	Boundary Road	
448	Boundary Road	
442	Boundary Road	
456	Boundary Road	
298	Boundary Road	
356	Boundary Road	
360	Boundary Road	
366	Boundary Road	
186	Breton Road	
134	Breton Road	
161	Breton Road	
102	Breton Road	
134	Breton Road	
109	Brien Avenue	W/C Ramp
109	Brien Avenue	
95	Bristol Place	
178	Bristol Place	
2	Bristol Place	
95	Bristol Place	
73	Brock Street	
116	Cambridge Place	
35	Canal Drive	
269	Carlbert Street	
9	Carmel Road	
33	Carmel Road	

# Curb And Sidewalk Program 2023

PROGRAM TOTALS	
Curb	341 Linear Metres
Sidewalk	1446 Square Metres
Accessibility Ramps	10 Highlighted in red

Civic Address	Street Name	Accessibility Ramp (W/C Ramp)
348	Cathcart Street	
107	Central Creek Drive	
263	Chambers Avenue	
321	Chambers Avenue	
350	Chambers Avenue	
267	Chambers Avenue	
440	Chambers Avenue	W/C Ramp
356	Chambers Avenue	
267	Chambers Avenue	
29	Chartwell Drive	
19	Chlebus Street	
146	Churchill Avenue	
264	Conmee Avenue	
280	Conmee Avenue	
71	Copernicus Drive	W/C Ramp
67	Copernicus Drive	W/C Ramp
162	Country Club Place	
115	Dacey Road	
429	Devon Road	
706	Douglas Street	
331	Douglas Street	
611	Douglas Street	
180	East Balfour Street	
59	Elmwood Avenue	
136	Estelle Street	
664	Farwell Terrace	
147	Florwin Drive	
124	Gibbs Street	
59	Gladstone Avenue	
246	Glen Avenue	
328	Goulais Avenue	
334	Goulais Avenue	
133	Greenview Court	
134	Grosvenor Avenue	W/C Ramp
134	Grosvenor Avenue	
28	Hardwood Street	W/C Ramp
41	Hargreaves Avenue	
54	Harten Street	
79	Heath Road	

# Curb And Sidewalk Program 2023

PROGRAM TOTALS	
Curb	341 Linear Metres
Sidewalk	1446 Square Metres
Accessibility Ramps	10 Highlighted in red

Civic Address	Street Name	Accessibility Ramp (W/C Ramp)
37	Heath Road	
45	Heath Road	
106	Henrietta Avenue	
111	Henrietta Avenue	
110	Henrietta Avenue	
363	Henry Street	
379	Henry Street	
224	Hugill Street	
209	Hugill Street	
44	Huntington Park	
35	Illinois Avenue	W/C Ramp
44	Indiana Drive	
24	Indiana Drive	
20	Indiana Drive	
27	Indiana Drive	
100	James Street	
47	Kerr Drive	
51	Kerr Drive	
36	Kerr Drive	
36	Kerr Drive	
40	Kerr Drive	
634	Korah Road	
674	Korah Road	
325	Korah Road	
1016	Lake Street	
588	Lake Street	
1015	Lake Street	
57	LaRonde Avenue	
175	LaRonde Avenue	
110	Lewis Road	
31	Mary Avenue	
31	Mary Avenue	
200	McNabb Street	
205	McNabb Street	
64	Millcreek Drive	
72	Millcreek Drive	
454	Moody Street	
52	Muriel Drive	
18	Newcastle Drive	

# Curb And Sidewalk Program 2023

PROGRAM TOTALS	
Curb	341 Linear Metres
Sidewalk	1446 Square Metres
Accessibility Ramps	10 Highlighted in red

Civic Address	Street Name	Accessibility Ramp (W/C Ramp)
93	Niagara Drive	
679	North Street	
1031	North Street	W/C Ramp
72	Northern Avenue East	
61	Northridge Road	
65	Northridge Road	
81	Oakwood Drive	W/C Ramp
37	Oakwood Drive	
81	Oakwood Drive	
79	Ontario Avenue	
39	Panoramic Drive	
360	Patrick Street	
360	Patrick Street	
769	Pine Street	
375	Pine Street	
779	Pine Street	
184	Promenade Drive	
138	Promenade Drive	
455	Queen Street West	
48	Raymond Street	
190	Reid Street	
194	Reid Street	
28	Rush Avenue	
28	Rushmere Drive	W/C Ramp
734	Shafer Avenue	
600	Shafer Avenue	
756	Shafer Avenue	
3	Sherwood Parkway	
15	Sherwood Parkway	
7	Sherwood Parkway	
66	Softwood Drive	
153	Spadina Avenue	
222	Spruce Street	
27	St. Mary's Avenue	
293	St. Mary's River Drive	
360	Sussex Road	
364	Sussex Road	
391	Sussex Road	
142	Trelawne Avenue	W/C Ramp

# Curb And Sidewalk Program 2023

PROGRAM TOTALS	
Curb	341 Linear Metres
Sidewalk	1446 Square Metres
Accessibility Ramps	10 Highlighted in red

Civic Address	Street Name	Accessibility Ramp (W/C Ramp)
142	Trelawne Avenue	
547	Wallace Terrace	
96	Weldon Avenue	
117	Weldon Avenue	
113	Weldon Avenue	
1564	Wellington Street East	
1560	Wellington Street East	
1291	Wellington Street East	
144	Westridge Road	
29	Windsor Street	
14	Winston Avenue	
192	Woodward Avenue	



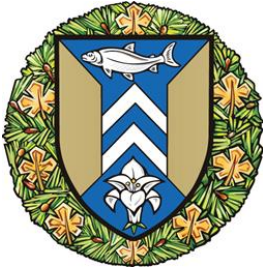

The Corporation of the  
City of Sault Ste. Marie  
**COUNCIL REPORT**

June 19, 2023

TO: Mayor Matthew Shoemaker and Members of City Council  
AUTHOR: Dan Perri, Municipal Services and Design Engineer  
DEPARTMENT: Public Works and Engineering Services  
RE: Rail Crossing Decommissioning – Carmen’s Way North of  
Conmee Avenue

---

**Purpose**

The purpose of this report is to obtain Council support to decommission the rail crossing at Carmen’s Way north of Conmee Avenue.

**Background**

Agawa Canyon Railway (ACR) approached City staff to decommission the rail crossing on Carmen’s Way, approximately 180m north of Conmee Avenue in conjunction with the 2023 Connecting Link resurfacing program. This crossing is the rail spur extending from the main rail line at mile 2.62 of the Soo Subdivision terminating at 150 Conmee Avenue.

**Analysis**

For ACR to obtain approval from the Ministry of Transportation to decommission the rail crossing, the City must support the decommissioning. ACR advises that this spur is inactive.

**Financial Implications**

All work associated with decommissioning the crossing will be the responsibility of ACR. There is no financial impact associated with this report.

**Strategic Plan / Policy Impact / Climate Impact**

This report is linked to the infrastructure focus area of the strategic plan.

**Recommendation**

It is therefore recommended that Council take the following action:

Resolved that the report of the Municipal Services and Design Engineer dated June 19, 2023 concerning Rail Crossing Decommissioning be received and that Council support the decommissioning of the rail crossing at Carmen’s Way north of Conmee Avenue.

Rail Crossing Decommissioning – Carmen’s Way North of Conmee Avenue

June 19, 2023

Page 2

Respectfully submitted,

Dan Perri, P.Eng.

Municipal Services and Design Engineer

705.759.5329

[d.perri@cityssm.on.ca](mailto:d.perri@cityssm.on.ca)

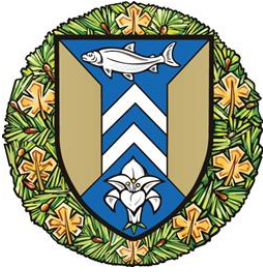

The Corporation of the  
City of Sault Ste. Marie

## COUNCIL REPORT

June 19, 2023

TO: Mayor Matthew Shoemaker and Members of City Council  
AUTHOR: Maggie McAuley, Municipal Services and Design Engineer  
DEPARTMENT: Public Works and Engineering Services  
RE: Contract 2023-8E Carmen's Way Resurfacing

---

### **Purpose**

The purpose of this report is to obtain approval to award Contract 2023-8E. The project includes the resurfacing of Carmen's Way from Queen Street to Second Line including the construction of a Hub Trail spoke on Albert Street West from Carmen's Way to James Street and upgrading of the Hub Trail on Carmen's Way from Second Line West to White Oak Drive.

### **Background**

On April 14, 2023, the Province announced that the City of Sault Ste. Marie had been selected for funding through the Ministry of Transportation 2023-24 Connecting Links Program. The Ministry's maximum provincial contribution for 2023 is \$3,000,000 towards the resurfacing of Carmen's Way.

On May 26, 2023, Infrastructure Canada announced funding to support upgrading portions of the Hub Trail and the Hiawatha Highlands and Conservation Area Connector Trail through the Active Transportation Fund. The maximum contribution is \$1,200,000 for both projects

### **Analysis**

A total of two (2) tenders were received. The tender submissions were reviewed and found to be complete and valid. The low tender of \$3,026,006.23 (excluding HST) was received from Pioneer Construction Incorporated.

### **Financial Implications**

The combined City/Connecting Link budget for this project is \$3,400,000, in addition to the funding provided by the Active Transportation Fund.

When non-recoverable HST and utility allowances are added, the City's cost to complete this project is projected to be \$3,081,264. This amount can be accommodated within the available combined City, Connecting Link and Active Transportation Fund budget.

### **Strategic Plan / Policy Impact / Climate Impact**

This report is linked to the infrastructure focus area of the strategic plan.

Contract 2023-8E Carmen's Way Resurfacing

June 19, 2023

Page 2

**Recommendation**

It is therefore recommended that Council take the following action:

The relevant By-law 2023-102 is listed under item 12 of the Agenda and will be read with all by-laws under that item.

Respectfully submitted,

Maggie McAuley, P. Eng.

Municipal Services and Design Engineer

705.759.5385

[m.mcauley@cityssm.on.ca](mailto:m.mcauley@cityssm.on.ca)

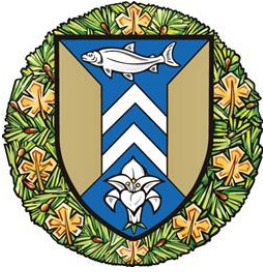

The Corporation of the  
City of Sault Ste. Marie  
**COUNCIL REPORT**

June 19, 2023

TO: Mayor Matthew Shoemaker and Members of City Council  
AUTHOR: Peter Johnson, Fire Chief  
DEPARTMENT: Fire Services  
RE: Fire Services By-Law Updates 2023

---

**Purpose**

The purpose of this report is to advise Council of updates to applicable Fire Services by-laws.

**Background**

Reports from the Fire Chief dated June 25, 2018 and June 13, 2022 were presented to Council containing multiple Fire Services by-laws. Due to recent retirements, the individuals named in the by-laws have changed and revisions are required.

**Analysis**

The *Municipal Act, 2001* requires a municipality to enact a number of by-laws to operate the municipality and specifically its fire department. In addition to meeting this legislative responsibility, by-laws provide the community with important information regarding the level of service that a municipality intends to provide. By-laws also provide municipal staff with the authorization to provide these services and the responsibility to achieve the prescribed service level.

The updates include the following:

By-law 2023-97 is a by-law to appoint Naomi Thibault as Deputy Chief Fire Prevention, Education and Emergency Management (repealing By-law 2018-139).

By-law 2023-98 is a by-law to appoint Gary Schryer as a Fire Prevention Officer (repealing By-law 2022-110).

**Financial Implications**

There is no financial impact.

**Strategic Plan / Policy Impact / Climate Impact**

Service Delivery – the by-laws contained in this report will ensure that the City of Sault Ste. Marie Fire Services will continue to provide efficient and effective service to the community, resulting in excellent customer service.

Fire Services By-Law Updates 2023

June 19, 2023

Page 2.

**Recommendation**

It is therefore recommended that Council take the following action:

The relevant By-laws 2023-97 and 2023-98 are listed under item 12 of the Agenda and will be read with all by-laws under that item.

Respectfully submitted,

Peter Johnson

Fire Chief

705.949-3333

[p.johnson@cityssm.on.ca](mailto:p.johnson@cityssm.on.ca)

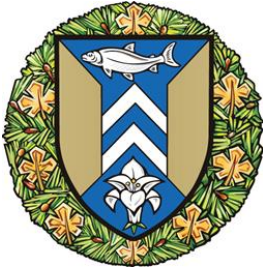

**The Corporation of the  
City of Sault Ste. Marie**

**C O U N C I L   R E P O R T**

June 19, 2023

TO: Mayor Matthew Shoemaker and Members of City Council  
AUTHOR: Jeffrey King, Solicitor  
DEPARTMENT: Legal Department  
RE: Update – Vacant Building Enforcement and Proposed By-Law and Amendments

---

**Purpose**

The purpose of this report is to recommend that Council pass the following: the proposed By-law amendments to the City's Property Standards By-law; the proposed amendments to the Yard Maintenance By-law; and to approve the proposed Vacant Building By-law.

**Background**

As per the recommendations of the Property Standard Task Force, staff recommended that Council pass amendments to the City's Property Standards By-law on June 14, 2021. Following the passing of the recommended amendments, and because vacant property in the City remains a concern of Council, Council then moved two resolutions on July 11, 2022 for updates on progress made and activities surrounding the vacancy amendments and yard maintenance. A further report was provided on September 19, 2022. As noted in the September report, staff continued to regularly examine the City's Property Standard By-law and general procedures for methods that may assist in combating the ongoing issues that arise with vacant buildings and yard maintenance.

Further, staff provided Council a specific update with respect to the Old Hospital site on December 12, 2022.

Further, on March 20, 2022, a resolution was put forward on the potential of enacting a Vacant Property Tax. A Vacant Property Tax By-law requires provincial approvals and will take time to put in place. That resolution will be dealt with in a further report, however it will not be possible this summer to propose it, however it does form part of the continuing focus on the management of vacant property. Initial Property Standard Task Force discussions surrounded a potential vacant building registry. At the time of recommending the Property Standards By-law amendments to Council for approval, it was determined that unknown factors such as the impact to staff resources and information supporting the number of vacant

buildings was speculative. It was therefore not recommended to action a registry approach at that time, but does form part of the proposal in this report.

### **Analysis**

It has been two years since the passing of the initial amendments to the Property Standards By-law. While success in the courtroom continues, actual street level change is slow to be seen in the community. Summer is where tall grass will begin to be obvious and is one indicator of a vacant buildings, the other being unmaintained driveways in the winter.

Staff recommends at this time, that the City look to implement a Vacancy Building By-law with registry components to take effect at a later time, and implement some further amendments to the Property Standards By-law and Yard Maintenance By-law. The registry could further serve to determine buildings that would be subject to a future vacant properties tax. The proposed amendments could also assist to return vacant buildings to market and increase the housing stock within the City.

Other community's actions regrading vacant buildings are as follows. Ottawa has recently implemented both a vacant building registry and vacant tax system. Staff also reviewed the Cities of Aurora, Cornwall, Brantford, Hamilton, St. Catherines, and Welland, all of which have implemented vacant property registries. The Cities of Brampton and London have specific by-laws for vacant buildings, but these by-laws do not consist of a registry/fee. Northern communities such as North Bay and Thunder Bay have also developed a vacant building by-law and registry system.

In some of the by-laws reviewed, and a recommended approach by staff, is to act against buildings that remain vacant for a full calendar year. These prolonged vacant buildings can be ordered demolished if within the criteria to do so, or otherwise looked at for expropriation, if appropriate. Staff further recommends that should this occur, a specific by-law to enable such demolition would be brought before Council for consideration and allocation of required dollars from the demolition fund.

The number of vacant buildings within the City from last calculation is approximately 90. With a modest fee of \$250.00 per registration, a registry can assist the involved departments recover \$22,500.00 for time it is currently dedicating to the unofficial vacant building tracking. The re-inspection fee would continue per the City's User Fee By-law, to serve as a further cost recovery measure.

The framework of a registry also enables information to flow from owners to the City in a less adversarial way. Where voluntary compliance is not met it will provide for enforcement. Officers could issue a relevant order or pursue a charge for non-registration or place the vacant property on the registry upon notice to the owner. These tasks are currently being conducted by officers without the opportunity for vacant building owners to voluntarily adhere to the requirements within the current



By-law framework. The registry would have specific registry exemptions against registering seasonal homes, property that is otherwise vacant due to out-of-town health treatment, and building with an active permit to be constructed or renovated.

Operationally, Staff involvement with the registry component of the Vacant Building By-law would be similar to the current provisions under the Property Standards By-law approach, but with a more administrative function of taking in information, declarations, and fees. Properly registered vacant buildings would also ensure the City has on hand the most current information for owners.

Additionally, Staff has used the Vacant Building By-law to clarify an existing provision within the City's Streets By-law regarding "graffiti". The City's Streets By-law creates an offence for a person that "defaces or disfigures a public or private building, wall, fence, railing, sign, monument, post, pole or other property in or adjoining any street by... daubing with paint or other substance." The new provision would have an owner remedy any graffiti found on a vacant building.

Staff proposed within the Vacant Building By-law that the registry provisions take full effect in January of 2024. This will allow the Property Standards Task force to evaluate the viability of the Registry in more detail, contemplate the administrative impacts, look at supporting technology to facilitate the registration process, and monitor the degree of vacant building owners that come forward on a proactive basis. A report to inform Council of the above will be presented in advance of the anticipated effect date of the registry.

### **Financial Implications**

There are no financial impacts with regarding the proposed by-law amendments and Vacant Building By-law provisions which take immediate effect. The Registry components of the Vacant Building By-law, resource allocation, and costs will be reviewed and reported on in a future report to Council.

### **Strategic Plan / Policy Impact / Climate Impact**

This is an operational matter not directly articulated in the corporate Strategic Plan.

### **Recommendation**

It is therefore recommended that Council take the following action:

The relevant By-laws 2023-108, 2023-109 and 2023-110 are listed under Agenda item 12 and will be read with all by-laws under that item.

Respectfully submitted,

Jeffrey King  
Solicitor  
705.759.2662  
[j.king3@cityssm.on.ca](mailto:j.king3@cityssm.on.ca)

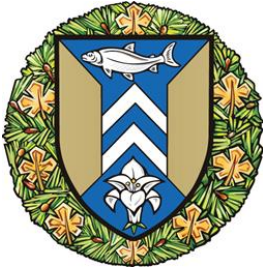

The Corporation of the  
City of Sault Ste. Marie  
**COUNCIL REPORT**

June 19, 2023

TO: Mayor Matthew Shoemaker and Members of City Council  
AUTHOR: Malcolm White, CAO  
DEPARTMENT: Chief Administrative Officer  
RE: CAO Selection Process

---

**Purpose**

To advise Council on the selection process for a new Chief Administrative Officer (CAO) and provide for the appointment of a CAO Selection Committee.

**Background**

Correspondence from the CAO was provided at the May 29, 2023 Council meeting providing the notice of intent to retire effective January 31, 2024. As noted in the correspondence, significant lead time is being provided to Council given the current recruitment environment.

The recruitment of senior staff, including the position of CAO, is governed by the policy Guidelines for the Recruitment and Selection of Senior Staff (attached). The policy has been revised to reflect current position titles and corporate structure.

**Analysis**

The process will be pursuant to the policy and be similar to the process used to in the selection of the previous two CAO selections. While the CAO Selection Committee has some discretion in the process conferred by the policy, in general terms the steps will entail:

- 1) Acquiring an executive recruiting firm to act as a resource and assist with all aspects of the process
- 2) Reviewing the current CAO by-law and recommending any revisions
- 3) Preparing the recruitment material including community profile, job posting and other recruitment materials
- 4) Reviewing applications and determining a shortlist for interview purposes
- 5) Conducting interviews and providing a recommendation to Council
- 6) Council appointment of a new CAO

**Financial Implications**

There are no financial implications associated with this report. The work of the CAO Selection Committee will incur costs associated with recruitment that will be reported to Council as the committee fulfills its duties.

**Strategic Plan / Policy Impact / Climate Impact**

The CAO position is the key position to ensure the implementation and completion of the Council approved strategic plan.

**Recommendation**

It is therefore recommended that Council take the following action:

Resolved that the report of the CAO dated June 19, 2023 concerning CAO Selection Process be received and that the following recommendations be approved:

- 1) That the revised policy Recruitment and Selection of Senior Staff be approved;
- 2) That Council authorize the filling of the upcoming vacancy of the Chief Administrative Officer;
- 3) That Mayor Shoemaker and Councillors \_\_\_\_\_ and \_\_\_\_\_ be appointed to the CAO Selection Committee.

Respectfully submitted,

Malcolm White

CAO

705.759.5347

[cao.white@cityssm.on.ca](mailto:cao.white@cityssm.on.ca)



**Subject:** Guidelines for the Recruitment and Selection of Senior Staff

**Service Area:** Human Resources

**File in Section:** Employment Practices

**Effective Date:** November 16, 1998

**Revision Date:** June, 2023

**Approved by:** City Council

---

**Purpose:**

Provide guidelines to be used in the recruitment of the Chief Administrative Officer (CAO) and the Senior Staff positions identified in the Scope section.

**Scope:**

These guidelines apply to the CAO and current Senior Staff positions. Senior Staff positions consist of CAO direct reports (Deputy CAO, City Solicitor, Chief Financial Officer/Treasurer, City Clerk, Fire Chief), and Director level positions.

**Procedures:**

**I Chief Administrative Officer (CAO)**

1. City Council shall authorize the filling of a CAO vacancy in an open Council meeting.
2. Upon approval of the filling of the vacancy City Council shall appoint a Selection Committee consisting of the Mayor and two (2) Councillors.

Note: The Director of Human Resources or designate shall act as a resource to the Selection Committee as may be required throughout the recruitment and selection process.

3. The Selection Committee shall carry out the recruitment and selection process and keep City Council advised throughout the process.

The recruitment and selection process may consist of some or all of the following:

A) Use of Consultants in the Recruitment Process

- RFP
- Selection of the Consultant
- Contract and costs

B) Establish Criteria for the Positions

- Review the job descriptions
- Update as necessary
- Establish qualifications and criteria for position



- C) Advertising of the Position
  - Internal posting only
  - Internal posting and external advertising
  - Local, Provincial or National advertising
  - Prepare posting/advertisement
- D) Receipt and Processing of Resumes
  - Resumes received by whom
  - Acknowledgment of receipt
  - Establish time frame for further contact
- E) Long Listing of Resumes
  - Establish criteria for "long list" of resumes
  - Establish a long list of applicants
  - Respond to all applicants regarding status of application
- F) The Interview Process
  - Determine the participants in the interview process.
  - Establish interview questions and interview process
- G) Recommend "Short List" of Candidates to City Council
- H) City Council interview of "Short List Candidates"
  - Determine the participants in the interview process
  - Establish the interview process and conduct interviews.
- I) Selection of successful candidate by City Council
  - Offer of Employment and Acceptance
  - Prepare Announcement
- J) Appointment by By-Law

**The Selection Committee may amend this recruitment process as necessary with the approval of Council.**

## II Senior Staff

1. Council shall authorize the filling of a Senior Staff vacancy. City Council may approve filling such vacancy through appointment or through a selection process.

Note:



For Senior Staff positions, inclusive of the City Solicitor, City Clerk and Fire Chief, the approval to fill such vacancy shall be in an open City Council meeting.

2.
  - a) If filled by appointment, the appointment is confirmed through passage of a By-law and by confirming to the employee such appointment in writing.
  - b) If approved to be filled by a Selection Process, a selection committee will be formed consisting of:
    - A member of Council appointed by Council, in the case of filling a position reporting to the CAO.
    - CAO or his designate
    - Director of Human Resources or designate
    - The respective area Head in Director level selections
    - Others as determined appropriate by the CAO.
3. The Selection Committee shall carry out the recruitment and selection process which may consist of the following:
  - A) Use of Consultants in the Recruitment Process
    - RFP
    - Selection of the Consultant
    - Contract and costs
  - B) Establish Criteria for the Positions
    - Review the job descriptions
    - Update as necessary
    - Establish qualifications and criteria for position
  - C) Advertising of the Position
    - Internal posting only
    - Internal posting and external advertising
    - Local, Provincial or National advertising
    - Prepare posting/advertisement
  - D) Receipt and Processing of Resumes
    - Resumes received by whom
    - Acknowledgment of receipt
    - Establish time frame for further contact
  - E) Short Listing of Resumes
    - Establish criteria for "short list" of resumes
    - Establish a short list of applicants
    - Respond to all applicants regarding status of application



- F) The Interview Process
  - Determine the participants in the interview process
  - Establish interview questions and interview process
  
- G)
  - 1. CAO direct reports – Recommendation to Council
    - a) CAO recommends successful candidate to Council
    - b) Offer of Employment and selection
    - c) Prepare Announcement
  
  - 2. Other Senior Management – Advise Council
    - a) Advise Council of candidate selected
    - b) Prepare Announcement
  
- H) Approve appointment by By-law.

**The Selection Committee may amend this recruitment process as necessary with the approval of Council.**

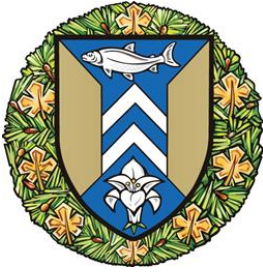

The Corporation of the  
City of Sault Ste. Marie  
**COUNCIL REPORT**

June 19, 2023

TO: Mayor Matthew Shoemaker and Members of City Council  
AUTHOR: Nicholas Cicchini, Junior Planner  
DEPARTMENT: Community Development and Enterprise Services  
RE: A-2-23-Z.OP 1692 Peoples Road (Luke Barban)

---

**PURPOSE**

The applicant, Luke Barban, has submitted an application to re-designate and rezone 1692 Peoples Road to permit a Carpentry Contractor's Yard.

**PROPOSED CHANGE**

The applicant is seeking Council's approval to Amend the Official Plan by way of a notwithstanding clause to the permitted uses in Section 2.3.6, to permit a Carpentry Contractor's Yard.

The applicant also wishes to rezone the subject property from Rural Aggregate Extraction Zone (REX) to Rural Aggregate Extraction Zone (REX.S) with a special exception to permit, in addition to the uses currently permitted in an REX zone, a Carpentry Contractor's Yard subject to the following provisions:

- Reduce the required interior (south) side yard setback from 30m to 2m for the existing scale house only;
- Reduce the required interior side yard setbacks from 30m to 5m.
- Reduce the required front yard setback from 30m to 25m; and
- Permit outdoor storage and accessory use freight containers on the subject property. Subject to the provision that they not encroach into the required front or the required side yards.

**Subject Property:**

- Location: 1692 Peoples Rd, is located on the east side of Peoples Rd approximately 1.6km North of Fourth Line and Peoples Rd intersection.
- Approximate Size: 100.6m of frontage, depth of 380.5m and area of 3.83Ha (9.46 Acres).
- Present Use: Motor Vehicle Salvage Yard
- Owner: Stray Dog Investments Ltd.

**BACKGROUND**

No prior planning applications have been submitted regarding the subject property.



## **ANALYSIS**

1692 Peoples Road was formerly a motor vehicle salvage yard and now it is being proposed through application A-2-23-Z.OP for a Carpentry Contractor's Yard; consisting of a carpentry shop, office building, and indoor/outdoor storage.

The applicant proposes to landscape the front yard, including naturally vegetated berms to buffer the property. The rear portion of the property will remain undeveloped at this time.

### **Conformity with Official Plan**

As per Schedule C (Land Use), the Official Plan designates the property as Rural Area. As per the Official Plan, Rural Area land uses generally include agriculture, forestry, extractive uses such as aggregate mining, and limited residential development. The Rural Area is all of the area within the municipality that is outside of the Urban Settlement Area.

A Carpentry Contractor's Yard is not an articulated use within the Rural Area policies and therefore, an Official Plan Amendment, by way of a notwithstanding clause is required.

The subject property is also on a site that has aggregate potential, adjacent to aggregate pits, and is zoned to permit aggregate extraction. The Official Plan's policy is to maintain aggregate development potential and secure this potential by limiting the encroachment of sensitive uses within the property's influence area.

A Carpentry Contractor's Yard is not considered a sensitive use, therefore it will not impact existing adjacent aggregate pits or future opportunities on the remainder of the subject property.

The subject property has been identified to be located in a Groundwater Recharge Area. The Groundwater Recharge Protection Area is an area of sand and gravel deposits which allow for surface water to percolate downward, recharging the groundwater aquifer. This aquifer serves as a source for the local water supply. Groundwater Recharge Protection policies are critical to ensuring that source water is not contaminated by the operation of certain land uses.

Through consultation with Sault Ste. Marie Regional Conservation Authority, it was determined that the proposed use does not qualify as a Significant Drinking Water Threat. Although, the applicant should take caution with handling and storage of organic solvents, dense nonaqueous phase liquids (DNAPLs), and fuel.

### **Conformity with Provincial Policy Statement 2020**

The Provincial Policy Statement 2020 (PPS) provides policy direction on matters of provincial interest related to land use planning and development. Council decisions must be consistent with the policies contained in the PPS.

This proposal is consistent with the Provincial Policy Statement. As per the Provincial Policy Statement: Rural Area: 1.1.4.1 Healthy, integrated and viable rural areas should be supported by: b) promoting regeneration, including the redevelopment of brownfield sites.

The previous use of the subject property was a motor vehicle salvage yard, classifying the property as a brownfield site. The activities outlined in this proposal represents redevelopment of a brownfield site. Thus the proposal is in conformity with the Provincial Policy Statement.

Similarly to the Official Plan's policy, through PPS policies, aggregate resources must be protected from land uses that would cause land use capability issues.

### **Conformity with Growth Plan for Northern Ontario 2011**

The Growth Plan for Northern Ontario 2011 (GPNO) establishes a framework for managing growth in Northern Ontario. Council's decision must either conform or not conflict with the plan. The proposed amendment has been reviewed against the GPNO, it does not conflict with the Growth Plan for Northern Ontario.

### **COMMENTS**

The subject property is zoned Rural Aggregate Extraction (REX). The proposed change is to include a Carpentry Contractor's Yard in addition to the existing permitted uses.

As per the attached site plan, the approximate front (West) 153m of the site will be redeveloped for the purposes of the Carpentry Contractor's Yard and the remaining rear (East) portion of the parcel may be used for future aggregate extraction. In the future, accessory uses to the carpentry business such as a warehouse building and office space are also proposed.

As per Zoning By-law 2005-150, Open Pit Aggregate Extraction is permitted upon the subject property, subject to the removal of a Holding Provision and Provincial pit license approvals.

The proposed development represents a significant improvement of the site. The property was previously a motor vehicle salvage yard – scrapped vehicles are being removed from the site. Improvements to the frontage by way of a berm with natural vegetation will enhance the streetscape and visually buffer the site from the street.

Reduced South Interior Setback from 30m to 2m – Scale House

The required interior (south) side yard setback is proposed to be reduced from 30m to 2m for the existing scale house only. The purpose is to bring the scale house into conformity with Zoning By-law 2005-150.

Reduced Interior Side Yard Setbacks from 30m to 5m

As per the zoning by-law, a 30m setback for buildings, structures, and pits are required along all lot lines. Where a pit abuts another pit, the setback distance is 0m (i.e. no setback requirement).

No land use impacts are anticipated from this reduction of the required setback given that neither the surrounding aggregate operation nor proposed carpentry use is sensitive in nature. They both have characteristics of an industrial activity.

Reduced Front Yard Setbacks from 30m to 25m

The reduction of the required front yard setback is to allow for additional parking to support the intended use of the property. This will not impact the streetscape as a deep front yard of 25m will exist. As per the site plan, berms will be created with natural vegetation to provide a barrier between the contractor's yard and the streetscape. Overall, it is an aesthetic, environmental, and land use improvement of the site's existing condition.

**CONSULTATION**

Public notices were mailed to all neighbouring property owners within 120m of the subject property on Friday, May 26, 2023. The notice that was mailed to property owners is attached to this report. The notice was also advertised on the City website and in the Sault Star on Saturday, May 27, 2023.

**Public Comments**

No public comments have been brought to the attention of the Planning staff as of June 09, 2023.

**Application Circulation**

As part of the application review, this proposal was circulated to City divisions and external agencies for detailed technical review and comment.

Building, Algoma Public Health, Canada Post, Community Development and Enterprise Services, Economic Development, Engineering, Legal, and Public Works had no comments or objections to this application.

The following departments/agencies commented on this application:

PUC recommended that the owner contact PUC well in advance to discuss electrical servicing requirements of any proposed development.

Sault Ste. Marie Regional Conservation Authority noted that: they do not object to this application, but that the proposed development will require a permit from SSMRCA.

The following departments/agencies did not comment: Traffic, Legal, Fire Services, Municipal Heritage Committee, Ministry of Municipal Affairs, Bell Canada, and Rogers Communications Canada

### **FINANCIAL IMPLICATIONS**

Approval of this application will not result in any incremental changes to municipal finances.

### **STRATEGIC PLAN / POLICY IMPACT**

Approval of this application is not directly linked to any Strategic Directions contained within the Corporate Strategic Plan. There are no significant climate change impacts anticipated from this application.

### **SUMMARY**

The applicant, Luke Barban, has submitted an application to re-designate and rezone 1692 Peoples Road to permit a Carpentry Contractor's Yard.

Future plans include the construction of office space, warehousing, and outdoor storage that is associated with the Carpentry Contractor's Yard. In the future, the applicant may also utilize the rear of the property as an aggregate extraction pit.

This proposal represents improvement of the site as a result of a change of use from a motor vehicle salvage yard to a Carpentry Contractor's Yard.

The addition of a Carpentry Contractor's Yard is compatible with the surrounding open pit operations, without posing a land use compatibility issue with the residential uses that are located along the west side of People's Road.

### **RECOMMENDATION**

It is therefore recommended that Council take the following action:

Resolved that the report of the Junior Planner dated June 19, 2023 concerning application A-2-23-Z.OP be received and that Council approve this application subject to the following provisions:

1. Approve Official Plan Amendment No. 246 by way of a notwithstanding clause to Section 2.3.6, to permit a Carpentry Contractor's Yard;
2. Rezone the subject property from Rural Aggregate Extraction Zone (REX) to Rural Aggregate Extraction Zone (REX.S) with a special exception to permit, in addition to the uses currently permitted in an REX zone, a Carpentry Contractor's Yard subject to the following provisions:

- a. Reduce the required interior (south) side yard setback from 30m to 2m for the existing scale house only;
- b. Reduce the required interior side yard setbacks from 30m to 5m;
- c. Reduce the required front yard setback from 30m to 25m; and
- d. Permit outdoor storage and accessory use freight containers on the subject property subject to the provision that they not encroach into the required front or the required side yards.

3. Deem the subject property as an area of Site Plan Control.

And that the Legal Department be requested to prepare the necessary by-law(s) to effect the same.

Respectfully submitted,

Nicholas Cicchini  
Junior Planner  
705.759.5375  
[n.cicchini@cityssm.on.ca](mailto:n.cicchini@cityssm.on.ca)

1692 PEOPLES ROAD  
DESIGNED BY:

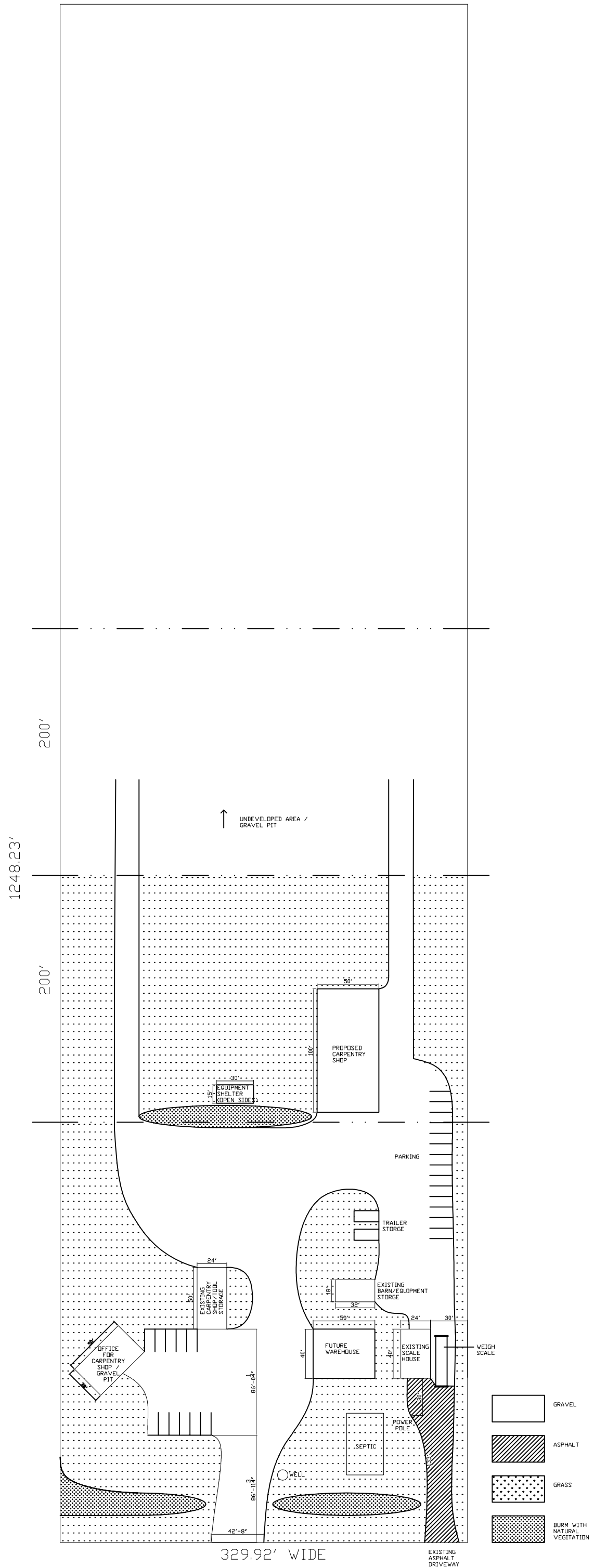

**AMENDMENT NO. 246  
TO THE  
SAULT STE. MARIE OFFICIAL PLAN**

**PURPOSE**

This Amendment is an amendment to the Text of the Official Plan as it relates to the Rural Area Policies of the Plan.

**LOCATION**

PT SEC 12 KORAH AS IN T277979; SAULT STE. MARIE, having Civic Address 1692 Peoples Road.

**BASIS**

This Amendment is necessary in view of a request to permit:

- A Carpentry Contractor's Yard on lands designated as Rural Area

Council now considers it desirable to amend the Official Plan.

**DETAILS OF THE ACTUAL AMENDMENT & POLICIES RELATED THERETO**

The Official Plan for the City of Sault Ste. Marie is hereby amended by adding the following paragraph to the Special Exceptions Section:

"Special Exceptions"

161. Notwithstanding the Rural Area policies of the Official Plan, the property described as PT SEC 12 KORAH AS IN T277979, having Civic Address 1692 Peoples Road may be occupied by a Carpentry Contractor's Yard as an additional permitted use.

**INTERPRETATION**

The provisions of the Official Plan as amended from time to time will be applied to this Amendment.

May 31, 2023

Peter Tonazzo  
Director of Planning  
The Corporation of the  
City of Sault Ste. Marie  
99 Foster Drive  
Sault Ste. Marie, ON P6A 5X6

Email: [s.perri@cityssm.on.ca](mailto:s.perri@cityssm.on.ca)

Dear Peter:

Re: Peoples Rd [1692] – Application No. #A-2-23-Z.OP

With regards to the above referenced rezoning application, please refer to the below comments:

PUC Distribution Inc. (Electric Utility)

- No concerns with the rezoning application.
- It is recommended that the owner contact PUC well in advance to discuss electrical servicing requirements of any proposed development.

Public Utilities Commission of the City of Sault Ste. Marie (Water Utility)

- No concerns with the rezoning application.

Please do not hesitate to contact us, should you have any further questions or concerns.

Yours truly,  
PUC Services Inc.



Mitchell Paradis, P.Eng.  
Manager, Electrical Engineering

MP\*km



## Nicholas Cicchini

---

**From:** Marlene McKinnon <mmckinnon@ssmrca.ca>  
**Sent:** May 17, 2023 12:06 PM  
**To:** Stephanie Perri  
**Subject:** SSMRCA Response - A-2-23-Z.OP - 1692 Peoples Road

**Importance:** High

This email originated outside of the Corporation of the City of Sault Ste. Marie.  
Do not open attachments or click links unless you verify the sender and know the content is safe.

May 17, 2023

Peter Tonazzo  
Planning Director  
City of Sault Ste. Marie  
P.O. Box 580  
Sault Ste. Marie, ON P6A 5N1

### **Conservation Authority Comments:**

**Application # A-2-23-Z.OP**  
**Luke Barban**  
**1692 Peoples Road**  
**Sault Ste. Marie**

The subject property is located in an area under the jurisdiction of the Conservation Authority with regard to the Ont. Reg.176/06 Development, Interference with Wetlands and Alterations to Shoreline and Watercourses.

The proposed development of the subject property as shown in the circulation will require a permit from SSMRCA.

Any future development on the subject property will require a permit from SSMRCA.

SSMRCA does not object to this application.

Sincerely,

M. A. McKinnon  
GIS Specialist  
Sault Ste. Marie Region Conservation Authority  
1100 Fifth Line East  
Sault Ste. Marie ON P6A 6J8  
[mmckinnon@ssmrca.ca](mailto:mmckinnon@ssmrca.ca)  
[www.ssmrca.ca](http://www.ssmrca.ca)  
Phone 705-946-8530

Fax 705-946-8533

Member of Canadian Institute of Geomatics

OPA-246 (T-161)

SUBJECT PROPERTY





Document Path: G:\Applications (2017 - Present)\Planning Act\Applications\2023\A-2-23-ZOP 1692 Peoples Road - Luke Barban\GIS Maps\A-2-23-ZOP\_AerialMap\_May2023\_8x11\_V1.mxd

**Application Map Series**  
 Subject Property  Official Plan Landuse  
 Existing Zoning  Aerial Image  
 Official Plan Amendment

**Legal Department Reference**

 **SAULT STE. MARIE**  
**Planning and Enterprise Services**  
 Community Development and Enterprise Services Department  
 99 Foster Drive, Sault Ste Marie, ON P6A 5X6  
 saultstemarie.ca | 705-759-5368 | planning@cityssm.on.ca

**Property Information**  
 Civic Address: 1692 Peoples Road  
 Roll No.: 050080020000000  
 Map No.: 503/2-60  
 Application No.: A-2-23-ZOP  
 Date Created: May 16, 2023

**Legend**  
 Subject Property: 1692 Peoples Road  
 Parcel Fabric

**Page 243 of 529**

*This map is for general reference only*  
 Orthophoto: 2022  
 Projection Details:  
 NAD 1983 UTM Zone 16N  
 GCS North American 1983

0 15 30 60 Meters  
 1:3,000



OPA-246 (T-161)

SUBJECT PROPERTY

1835

1819

1811

1803

1795

Peoples Road

Fifth Line West

1692

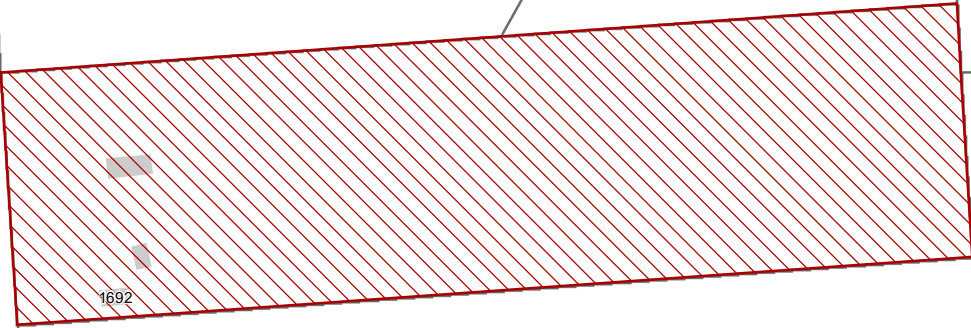

Document Path: G:\Applications (2017 - Present)\Planning Act Applications\2023\A-2-23-ZOP 1692 Peoples Road - Luke Barban\GIS Maps\A-2-23-ZOP\_SubjectPropertyMap\_May2023\_8x11\_V1.mxd

**Application Map Series**  
 Subject Property  Official Plan Landuse  
 Existing Zoning  Aerial Image  
 Official Plan Amendment

**Legal Department Reference**



**SAULT STE. MARIE**  
**Planning and Enterprise Services**  
 Community Development and Enterprise Services Department  
 99 Foster Drive, Sault Ste Marie, ON P6A 5X6  
[saultstемarie.ca](http://saultstемarie.ca) | 705-759-5368 | [planning@cityssm.on.ca](mailto:planning@cityssm.on.ca)

*This map is for general reference only*  
 Orthophoto: None  
 Projection Details:  
 NAD 1983 UTM Zone 16N  
 GCS North American 1983



**Property Information**  
 Civic Address: 1692 Peoples Road  
 Roll No.: 050080020000000  
 Map No.: 503/2-60  
 Application No.: A-2-23-ZOP  
 Date Created: May 16, 2023

**Legend**

 Subject Property: 1692 Peoples Road

 Parcel Fabric

Page 244 of 529

OPA-246 (T-161)

SUBJECT PROPERTY

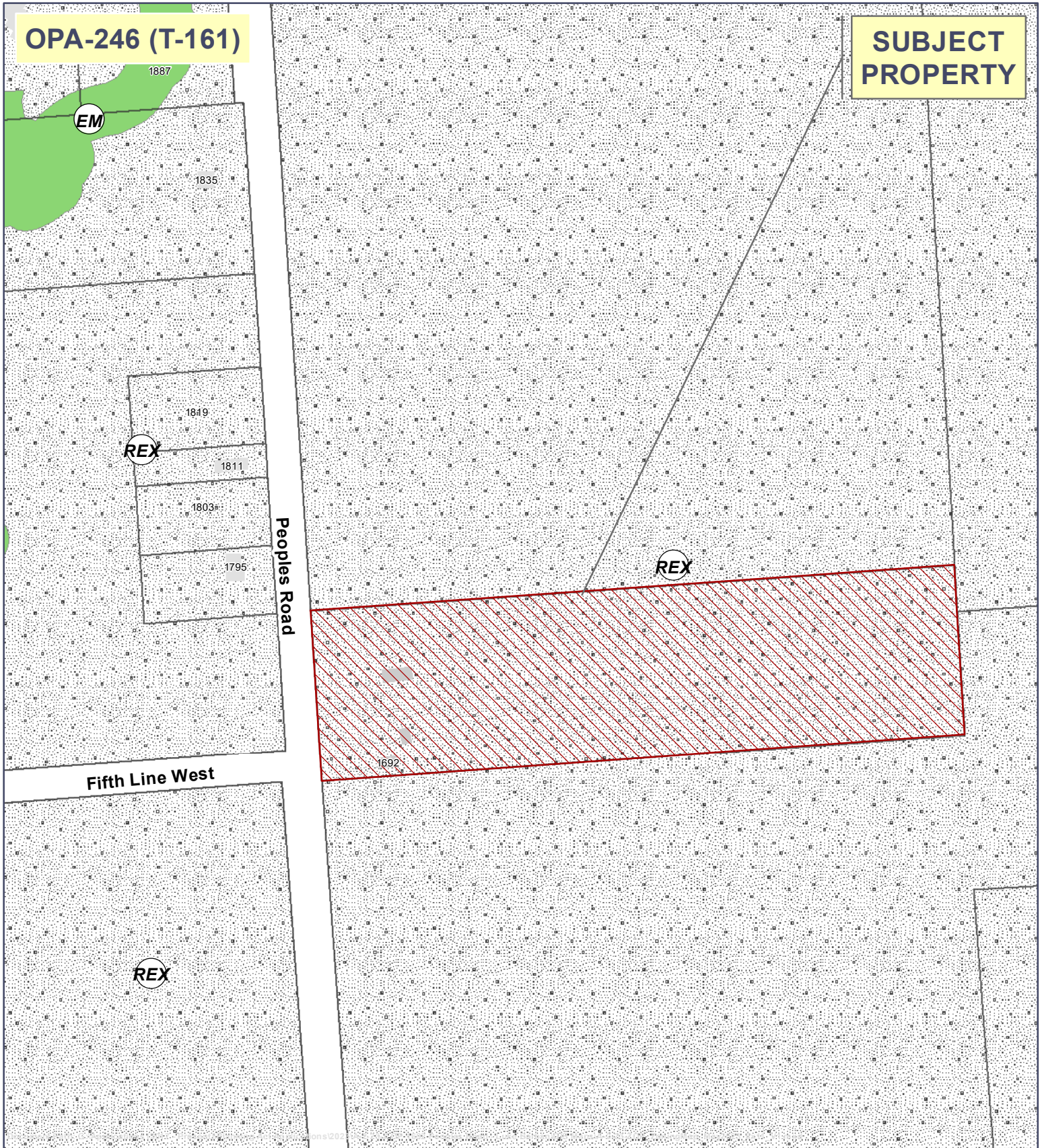

- Application Map Series**
- Subject Property
  - Official Plan Landuse
  - Existing Zoning
  - Aerial Image
  - Official Plan Amendment

**Property Information**

Civic Address: 1692 Peoples Road  
 Roll No.: 050080020000000  
 Map No.: 503/2-60  
 Application No.: A-2-23-ZOP  
 Date Created: May 16, 2023

**Legend**

- |   |                                       |
|---|---------------------------------------|
| C1 - Traditional Commercial Zone            | R3 - Low Density Residential Zone     |
| C2 - Central Commercial Zone                | R4 - Medium Density Residential Zone  |
| CT2 - Commercial Transitional Zone          | R5 - High Density Residential Zone    |
| C3 - Riverfront Zone; C3hp                  | R6 - Mobile Home Residential Zone     |
| C4 - General Commercial Zone; C4hp          | I - Institutional Zone                |
| C5 - Shopping Centre Zone                   | EM - Environmental Management Zone    |
| HZ - Highway Zone                           | PR - Parks and Recreation Zone        |
| M1 - Light Industrial Zone                  | RA - Rural Area Zone                  |
| M2 - Medium Industrial Zone; M2hp           | RP - Rural Precambrian Uplands Zone   |
| M3 - Heavy Industrial Zone                  | REX - Rural Aggregate Extraction Zone |
| R1 - Estate Residential Zone                | AIR - Airport Zone                    |
| R2 - Single Detached Residential Zone; R2hp | Named Use - Commercial Dock           |
|   | Parcel Fabric                         |
|   | Topography                            |



**SAULT STE. MARIE**

**Planning and Enterprise Services**

Community Development and Enterprise Services Department

99 Foster Drive, Sault Ste Marie, ON P6A 5X6

saultstemarie.ca | 705-759-5368 | planning@cityssm.on.ca

*This map is for general reference only*

Orthophoto: None

Projection Details:

NAD 1983 UTM Zone 16N

GCS North American 1983

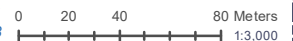



The Corporation of the City of Sault Ste. Marie  
99 Foster Drive, Sault Ste. Marie, Ontario P6A 5X6  
saultstemarie.ca | 705.759.2500 | info@cityssm.on.ca

## NOTICE OF APPLICATION & PUBLIC MEETING

**1692 Peoples Road**  
**Application No.: A-2-23-Z.OP**  
**Applicant: Luke Barban**

**Date: Monday, June 19, 2023**  
**Time: 5:30 PM**

**Location: City of Sault Ste. Marie**  
**Civic Centre, Council Chambers**  
**99 Foster Drive**

### PURPOSE

The applicant, Luke Barban, has submitted an application to re-designate and rezone 1692 Peoples Road to permit a carpentry contractor yard.

Future plans include the construction of office space, warehousing, and outdoor storage that is associated with the carpentry business.

### PROPOSED CHANGE

Amend the Official Plan by way of a notwithstanding clause to permit a carpentry business.

Rezone the subject property from Rural Aggregate Extraction Zone (REX.S) with a special exception to permit, in addition to the uses currently permitted in a REX zone, a carpentry contractor yard subject to the following provisions:

1. Reduce the required interior (south) side yard setback from 30 meters to 2 meters for the existing scale house only.
2. Reduce the required interior side yard setbacks from 30 meters to 5 meters.
3. Reduce the required front yard setback from 30 meters to 25 meters.
4. Permit outdoor storage and accessory use freight containers on the subject property, but they must not encroach into the required front or the required side yards.

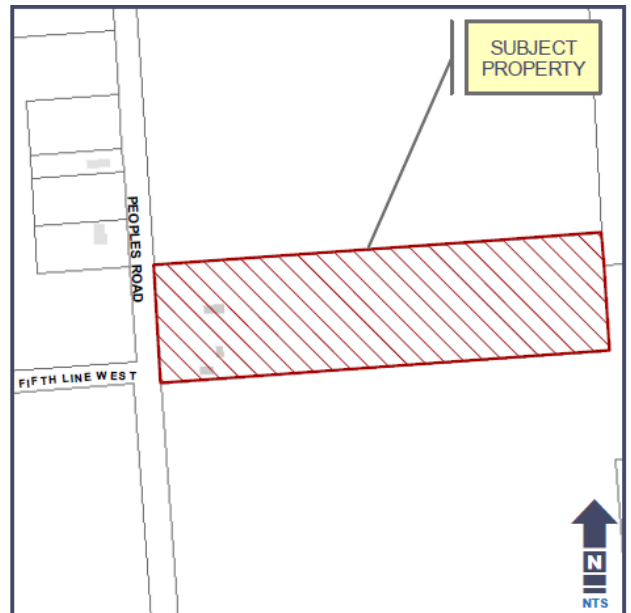

### HAVE YOUR SAY

Input on the proposed Zoning By-Law and Official Plan amendment is welcome and encouraged. You can provide input by making a written submission or by making a public presentation.

**TAKE NOTICE THAT** the Council of The Corporation of the City of Sault Ste. Marie will hold a Public Meeting on Monday, June 19, 2023 at 5:30 p.m. to consider an Official Plan Amendment and Zoning By-law Amendment (under sections 17, 22 and 34 of the Planning Act, R.S.O 1990, c. P13, as amended). This meeting will be broadcast by Shaw Cable and may be viewed on Shaw Cable's Community Channel, Sootoday.com and on the City's YouTube Channel <https://www.youtube.com/saultstemarieca>

Any person wishing to present at the public meeting may do so electronically or in person. Electronic participants must contact the City Clerk at [cityclerk@cityssm.on.ca](mailto:cityclerk@cityssm.on.ca) or 705-759-5388 to register as a presenter. Registered presenters will be provided with instructions as to how to join the meeting in advance Any written submissions received in advance of the meeting will be included with Council's Agenda.

### MORE INFORMATION

The application may be reviewed upon request. The report of the Planning Division will be available on Friday, June 16, 2023 as part of City Council's Agenda. Please contact Nicholas Cicchini 705.759.5375 or [n.cicchini@cityssm.on.ca](mailto:n.cicchini@cityssm.on.ca) to request a digital copy. Please refer to the application file number.

### WRITTEN SUBMISSION

To provide input in writing, or request notice if the proposed application is approved, please submit a letter to Nicholas Cicchini, 99 Foster Drive, Sault Ste. Marie, ON P6A 5X6, or e-mail to [n.cicchini@cityssm.on.ca](mailto:n.cicchini@cityssm.on.ca) with your name, address and application file number on or before **Monday, June 19, 2023**.

If you wish to be notified of the Council of the City of Sault Ste. Marie decision to adopt or refuse the approval of an application, you must make a written request to the Planning Division at the address noted above.

### LEGAL NOTICE CONCERNING YOUR RIGHT TO APPEAL

If a person or public body does not make oral submission at a public meeting or make written submission to the City of Sault Ste. Marie before the By-law is passed, the person or public body may not be entitled to appeal the decision of the Council of the City of Sault Ste. Marie to the Ontario Land Tribunal.

If a person or public body does not make oral submissions at a public meeting, or make written submissions to the City of Sault Ste. Marie before the By-law is passed, the person or public body may not be added as a party to the hearing of an appeal before the Ontario Land Tribunal unless, in the opinion of the Tribunal, there are reasonable grounds to add the person or public body as a party.

1692 PEOPLES ROAD  
DESIGNED BY:

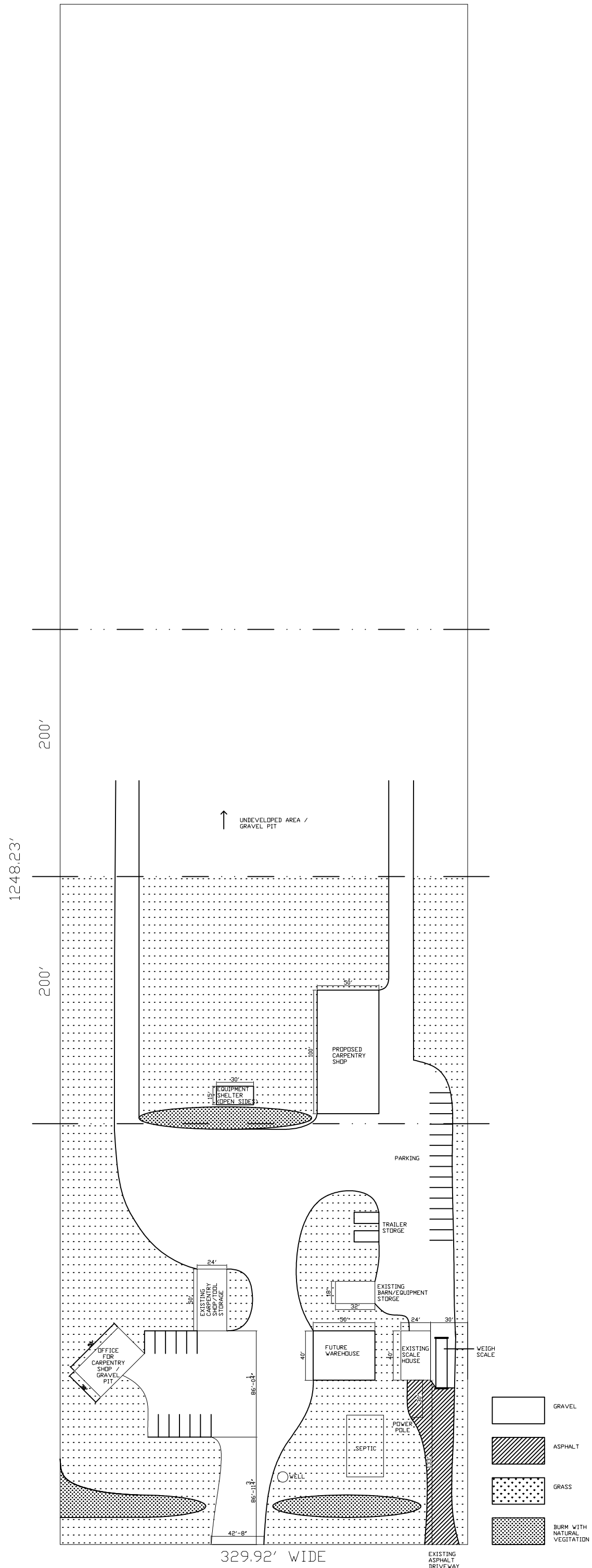

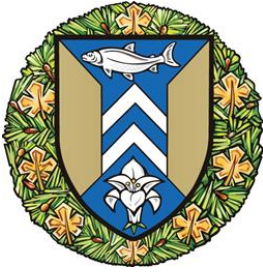

**The Corporation of the  
City of Sault Ste. Marie**

**C O U N C I L   R E P O R T**

June 19, 2023

TO: Mayor Matthew Shoemaker and Members of City Council  
AUTHOR: Salvatore Marchese, Junior Planner  
DEPARTMENT: Community Development and Enterprise Services  
RE: A-3-23-Z. OP 352/360 Northern Avenue & 31 Old Garden  
River Road (Cara Community Corporation)

---

**PURPOSE**

The applicant, Cara Community Corporation (C/O Sam Biasucci), has submitted an application for site specific Official Plan and Rezoning amendments. The effect of these amendments would facilitate the construction of a nine-storey building providing 108 residential units, 750m<sup>2</sup> of commercial space, and a chapel on the subject area. The commercial and chapel space will be located on the ground floor of the proposed building. The application also proposes to reduce the required side yard setbacks, reduce the number of required parking spaces, permit parking spaces in a required side yard setback, and slightly reduce the required amount of landscaped open space.

**PROPOSED CHANGE**

The applicant is seeking Council's approval to amend the Official Plan's residential land use policies by way of a notwithstanding clause to Policy R.7 to permit commercial development of up to 750m<sup>2</sup> on the subject area, whereas R.7 of the OP only permits 200m<sup>2</sup>. An amendment to the Official Plan's commercial land use policies is also proposed, by way of a notwithstanding clause to Policy C.4 to permit major office space outside of the defined Downtown Area.

Rezoning the subject area from High Density Residential Zone (R5.S-405) with Special Exception 405 to High Density Residential Zone (R5.S) with a new Special Exception to permit, in addition to the uses already permitted in an R5 zone, up to 750m<sup>2</sup> of commercial space, subject to the following provisions:

1. Permitted commercial uses include office uses, food services, personal services, retail trade, amusement and fitness facilities, arts culture and heritage uses, bingo halls, accessory uses, and similar uses. The foregoing uses are subject to the same regulations as the proposed apartment building;



2. Reduce the required east interior side yard setback to 0m to accommodate an enclosed corridor between the proposed building and the existing building on the abutting property;
3. Reduce the combined number of required parking spaces from 185 to 101 spaces for the proposed 108-unit apartment, the existing 4-unit multiple attached dwellings, the place of worship, and the commercial use of the property;
4. That a minimum of nine barrier-free parking spaces be provided;
5. Reduce the west exterior side yard setback from 13.5m to 4m;
6. Permit parking within the required front (south) and exterior (west) side yards;
7. Waive the need to provide a dedicated loading space as required by Section 6 of the Zoning By-Law; and
8. Reduce the required landscaped open space from 33% to 29%.

**Subject Property:**

- Location: The subject properties are located on the northeast corner of Northern Avenue East and Great Northern Road.
- Approximate Size: Of the subject area/area to be rezoned
  - 352/360 Old Garden River Road
    - Irregularly shaped with approximately 73m (239.5') frontage along Northern Avenue, 57m frontage along Great Northern Road and 60m frontage along Old Garden River Road, totalling 0.49ha (1.21 acres)
  - Southwest Portion of 31 Old Garden River Road
    - Irregularly shaped with approximately 32m frontage along Northern Avenue by 39m depth, totalling 0.125ha (0.31 acres)
    - Total Area– Approximately 0.617ha (1.52 acres)
- Present Use: Holy Trinity Church, 4-unit townhouse, apartment complex
- Owner: Cara Community Corporation

**BACKGROUND**

In 1980, Council approved a rezoning application to facilitate the construction of the existing apartment building (CARA 1) and townhouses located upon 31 Old Garden River Road.

In 2021 Council approved a rezoning application to permit the construction of a seven-storey apartment building and a place of worship upon 352/360 Northern Avenue and the southwest corner of 31 Old Garden River Road.

Development plans have since been revised and are now the subject of this application

## **ANALYSIS**

Cara Community Corporation maintains numerous rental units adjacent to the proposed development. Since successfully applying for a rezoning on the subject properties in 2021, development plans have changed, and a nine-storey apartment building with Commercial uses on the ground floor is now proposed.

The new special exception being requested by the applicant is similar in nature to the existing special exception. Further relief in required parking, as well as the request for a reduced exterior (west) side yard setback are the primary differences.

### **Conformity with Official Plan**

The subject property is designated Residential on Land Use Schedule C of the Official Plan. Residential lands are primarily used for dwellings, and a variety of other uses that contribute to the completeness of the neighbourhood. Small scale commercial uses which are compatible with the nature of the area are also permitted.

The development meets the intent of the City's Official Plan by bringing 108 new residential units to an area designated for high density residential growth. It is providing a mix of one and two bedroom units that offer a portion as affordable and barrier-free. The proposal looks to add to an area of intensification of the City and specifically meets the following housing and residential policies:

#### Housing Policies

HO.1 Opportunities for a full range of housing types shall be provided to meet the present and expected needs of the community.

HO.2 Innovative and alternative residential development standards supporting affordable housing and compact urban form shall be encouraged. However, climate (e.g. Snowfall) and other local circumstances should not be neglected.

HO.4 Medium and high density – including affordable housing – will be encouraged to be built before or at the same time as low density units

HO.6 For all urban residential developments greater than 50 units, the developer shall be required to provide a statement of affordability ensuring that opportunities for creating a range of housing types are provided so that no less than 30% of the new dwellings are affordable. Wherever feasible 50% of all affordable housing provided shall be affordable to low income households as defined by the Ministry of Municipal Affairs and Housing

#### Residential Policies

R.1 A mixture of housing types and diversity of ownership and tenure forms shall be encouraged in new development

R.2 Low and high density development should be integrated and compatible in density, height and building setbacks. Generally, high density development shall be restricted to major arterial streets and areas abutting the downtown core.

The development will bring additional housing units for residents of Sault Ste. Marie. The City currently has a vacancy rate of 1.7%, which is considered low. A healthy vacancy rate ranges between 3-5%. The provision of 33 of the 108 units being affordable satisfies requirements as set out in HO.6. The compact form of the development on the subject area allows for a high density housing option.

The development will provide the ability for people of various backgrounds including those who may choose not to have a vehicle, those looking to downsize from their current homes, students looking for accommodations, and those looking to relocate to a part of town with easy access to services.

The project is situated on an arterial street with access to nearby amenities available by various methods of travel. These include a well connected system of sidewalks and access to nearby transit. The adjacent CARA complex has a playground on site that may be used by residents.

### **Conformity with Provincial Policy Statement 2020**

There are a number of policies that are applicable to this application

1.3.1 Planning authorities shall promote economic development and competitiveness by:

- a) providing for an appropriate mix and range of employment, institutional and broader mixed uses to meet long-term needs

1.4.3 Provincial Policy encourages a mix of housing types and tenure, with a clear focus on encouraging the provision of affordable housing units.

This application conforms to the Provincial Policy Statement 2020.

### **Conformity with Growth Plan for Northern Ontario 2011**

This application does not conflict with the Growth Plan for Northern Ontario

### **COMMENTS**

The proposed residential density of the site is 175 units/hectare (71 units/acre) which can be classified as high density development within the local context. This level of density is appropriate as the subject property is located in a node with close access to surrounding retail, services, transit, and other amenities.

A-3-23-Z.OP 352/360 Northern Avenue and 31 Old Garden River (Cara Community Corporation)

June 19, 2023

Page 5.

The proposal seeks to intensify the use of an existing property adjacent to an arterial road (Great Northern Road). This project will bring 33 new affordable units in addition to adding more market supply units to the area.

The development requires an Official Plan Amendment to permit commercial use over 200m<sup>2</sup> in an area designated residential and to permit major office space outside the Downtown Area. Planning staff are supportive of permitting up to 750m<sup>2</sup> of commercial and/or office space on the subject property. The development is located in an identified node that is highlighted for a mix of land uses.

Previously, the 4-unit townhouse on the subject site was to be demolished as part of the application made in 2021, but will now be retained as part of this application in order to maintain housing units.

As proposed, there will be 39 one-bedroom units and 69 two-bedroom units, with 22 of the total units being barrier-free.

The ground floor will accommodate approximately 496m<sup>2</sup> of commercial space, the place of worship, and a community gathering room. The requested 750m<sup>2</sup> of permitted commercial space is to allow flexibility for the space that is to be used as a community gathering area in the future.

The commercial uses will generally be geared towards the tenants of the building, and will foster a mixed use development that provides additional access to services for the tenants.

The reduction of the required east interior side yard setback is to allow for an enclosed corridor between the proposed and existing building that will facilitate shared access of amenities for the residents.

A reduction in parking from 185 spaces to 101 spaces is also being sought. Planning staff support this reduction as a result of the nearby services and amenities being within walking distance, reducing the reliance on a vehicle. The Planning Department is currently undertaking a parking study with the overall goal of reducing minimum parking requirements. According to CARA, the existing apartment building has a parking utilization rate of 60%. The proposed development is expected to have a similar parking utilization rate given that the demographics will be similar.

The required barrier-free parking ensures that the development will have the required amount of accessible parking spots as required by the zoning bylaw prior to the overall parking reductions requested by this application. No reductions for barrier-free parking are required.

The request to permit parking in a required front (south) and exterior (west) side yard setback is also supported. The overall landscaping for the development exceeds what already exists on the site. Additionally, there will be access to a rooftop patio for the tenants. Site plan control will be utilized to ensure high quality landscaping is provided. This will soften the presence of parking in the setbacks and ensure that the site meets the expected standards of a gateway corridor.

The new development plan requires an additional setback on the exterior (west) side yard from 13.5m to 4m. These setbacks apply only to two corners of the building and are considered minor.

Relief from the requirement to provide a dedicated loading space is being sought by the applicant. Section 6 of the Zoning By-law requires one dedicated loading space which must be screened from the Street. The development contains two internal rooms on the ground floor of the development that are dedicated to moving space and refuse collection that are accessible by overhead doors from the east parking lot. There will be additional space outside the access doors and use of the parking aisle to satisfy loading requirements. Site plan control will be used to ensure there is appropriate space to meet the intention of the Zoning Bylaw.

A minor reduction in the required open space from 33% to 29% is requested by the applicant to accommodate the application. There will be a rooftop patio that offsets part of the effect of this reduction, however it will most likely be closed in the winter months. As mentioned, the overall landscaping will be increased from what currently exists.

## **CONSULTATION**

Public notices were mailed to all neighbouring property owners within 120m (400') of the subject property on Friday May 26, 2023. The notice that was mailed to property owners is attached to this report. The notice was also posted on the City website and advertised in the Sault Star on May 27, 2023.

A public neighbourhood meeting was held on May 23, 2023 in the Community Room at the existing CARA 1 apartments by the applicant. A Ward Councillor was in attendance along with 11 members of the public. The majority of questions revolved around operations and servicing of the new building including provisions for cable services and access to the rooftop patio. One comment was made about the aesthetics of the building.

Concerns over the pedestrian crossing signal timing at the Northern Avenue and Great Northern Road intersection were also raised. The east/west crossing was reported to be too short for pedestrians to safely cross the intersection.

Engineering staff have confirmed that the current timing for east/west pedestrian crossing is set to 7 seconds of a walking signal plus an additional 16 seconds of a flashing upraised hand. These times exceed those recommended in the Ontario Traffic Manual.

Planning staff, the Accessibility Advisory Committee, and Engineering Services will continue to monitor this issue.

### **Public Comments**

A representative for a nearby commercial property called the Planning Department to discuss the impact of the reduced parking and additional commercial space in the area. After discussing the proposal with them they had no objection to it proceeding.

### **Application Circulation**

As part of the application review, this proposal was circulated to City divisions and external agencies for detailed technical review and comment. The following departments/agencies commented on this application:

**Accessibility:** Would like there to be consideration given to those with mobility considerations with the crossing at Great Northern Road and Northern Avenue.

**Building:** Consideration must be taken into account for Ontario Building Code regulations that will be affected by constructing closer to the property line. These include construction requirements when a building is closer to overhead power lines. These items will be addressed through site plan control to ensure conformity.

**Canada Post:** If the rezoning is approved and a plan is put forth, then Canada Post will need to comment at that time.

**PUC:** PUC would like to take the opportunity to request that the developer reach out to PUC early in the planning stages with respect to water and electrical servicing for the development.

**Engineering:** Stated that the conditions from the previous application hold true for the new application and are as follows:

Engineering Services notes that during the site plan control process, servicing and drainage will be reviewed in detail, to the satisfaction of the Director of Engineering or designate. A complete site plan control application will require a lot grading and drainage plan, completed by a lot grading professional.

Engineering notes that a 3m road widening is required along Northern Avenue. The applicants are aware of this, which will be a requirement of the site plan control agreement. The 3m road widening has been included on the attached site plan included with the application. Engineering is satisfied that given the vehicle volumes currently operating in the area, the additional trips generated by this development will not have a negative effect on road capacity.

### **FINANCIAL IMPLICATIONS**

Approval of this application will not result in any incremental changes to municipal finances.

### **STRATEGIC PLAN / POLICY IMPACT**

Approval of this application is not linked to any policies within the Corporate Strategic Plan. There are no significant climate change impacts anticipated from this application.

### **SUMMARY**

This application is a revision of a previously submitted and approved application. The applicant is seeking variances that are necessary for the building to be economically feasible while satisfying requirements of CMHC. The building is similar to the project under construction at 96 Great Northern Road.

The area is located nearby many services and amenities. The area is well serviced by public transit routes. 30% of units will be affordable, which is important to the community.

### **RECOMMENDATION**

It is therefore recommended that Council take the following action:

Resolved that the report of the Junior Planner dated June 19, 2023 concerning Rezoning Application A-3-23-Z.OP be received and that Council:

1. Approve Official Plan Amendment 247, by way of a notwithstanding clause to Policies R.7 and C.4 to permit up to 750m<sup>2</sup> of commercial development, including major office space, upon the subject property.
2. Rezone the subject area from High Density Residential Zone (R5.S-405) with Special Exception 405 to High Density Residential Zone (R5.S) with a new Special Exception to permit, in addition to the uses already permitted in an R5 zone, up to 750m<sup>2</sup> of commercial space, subject to the following provisions:
  - a. Permitted commercial uses include office uses, food services, personal services, retail trade, amusement and fitness facilities, arts culture and heritage uses, bingo halls, accessory uses and similar. The foregoing

- uses are subject to the same regulations as the proposed apartment building;
- b. Reduce the required east interior side yard setback to from 13.5m to 0m to accommodate an enclosed corridor between the proposed building and the existing building on the abutting property;
  - c. Reduce the combined number of required parking spaces from 185 to 101 spaces for the proposed 108-unit apartment building, the existing 4-unit multiple attached dwellings, the place of worship, and the commercial use of the property;
  - d. Provide a minimum of nine barrier-free parking spaces;
  - e. Reduce the west exterior side yard setback from 13.5m to 4m;
  - f. Permit parking within the required front (south) and exterior (west) side yards;
  - g. Waive the need to provide a dedicated loading space as required by Section 6 of the Zoning By-Law; and
  - h. Reduce the required landscaped open space from 33% to 29%.

The relevant By-laws 2023-104 and 2023-105 are listed under Agenda item 12 and will be read with all by-laws under that item.

Respectfully submitted,

Salvatore Marchese  
Junior Planner  
705.759.5445  
s.marchese@cityssm.on.ca



**SITE PLAN REQUIREMENTS:**

**AREAS:**

TOTAL SITE AREA	=6024.6m <sup>2</sup>
EXISTING 4 UNIT TOWNHOME BLDG.	=189m <sup>2</sup>
PROPOSED 108 UNIT / 9 STOREY APARTMENT BUILDING (FOOTPRINT)	=1616m <sup>2</sup> (NOT INCLUDING PATIOS)
TOTAL BUILDING AREA	=1804m <sup>2</sup>
LOT COVERAGE PROPOSED	=29.9%
MAX. ALLOWABLE LOT COVERAGE	=33%
LANDSCAPED AREA	=1709m <sup>2</sup> + 122m <sup>2</sup> (ROOF TOP OVER RAMPS)
	=1831m <sup>2</sup>
MIN. ALLOWABLE LANDSCAPING	=33%
LANDSCAPING AREA PROPOSED	=30.4% (MINOR VARIANCE REQ'D)

**PARKING REQUIRED:**

EXISTING TOWNHOMES (4 UNITS) AT 1 SPACE / UNIT	= 4 SPACES
PROPOSED 108 UNIT APARTMENT AT 1.25 SPACES / UNIT	= 135 SPACES
TOTAL SPACES REQUIRED	= 139 SPACES

**PARKING PROVIDED:**

ABOVE GROUND PARKING	= 53 SPACES
BELOW GROUND COVERED PARKING	= 48 SPACES
TOTAL SPACES PROVIDED	= 101 SPACES (MINOR VARIANCE REQ'D)

**SETBACKS REQUIRED:**

NORTH	= 13.5m (1/2 BLDG HT.)
SOUTH	= 13.5m (1/2 BLDG HT.)
EAST	= 13.5m (1/2 BLDG HT.)
WEST	= 13.5m (1/2 BLDG HT.)

**SETBACKS PROVIDED:**

NORTH	= 26.46m	V1 (MINOR VARIANCE 1)	= 7.61m
SOUTH	= 16.04m	V2 (MINOR VARIANCE 2)	= 9.16m
EAST	= 7.98m	V3 (MINOR VARIANCE 3)	= 8.94m
WEST	= 4.34m		

**EXISTING ZONING:**  
R5 - HIGH DENSITY RESIDENTIAL ZONE

**PROPOSED ZONING:**  
R5 - HIGH DENSITY RESIDENTIAL ZONE

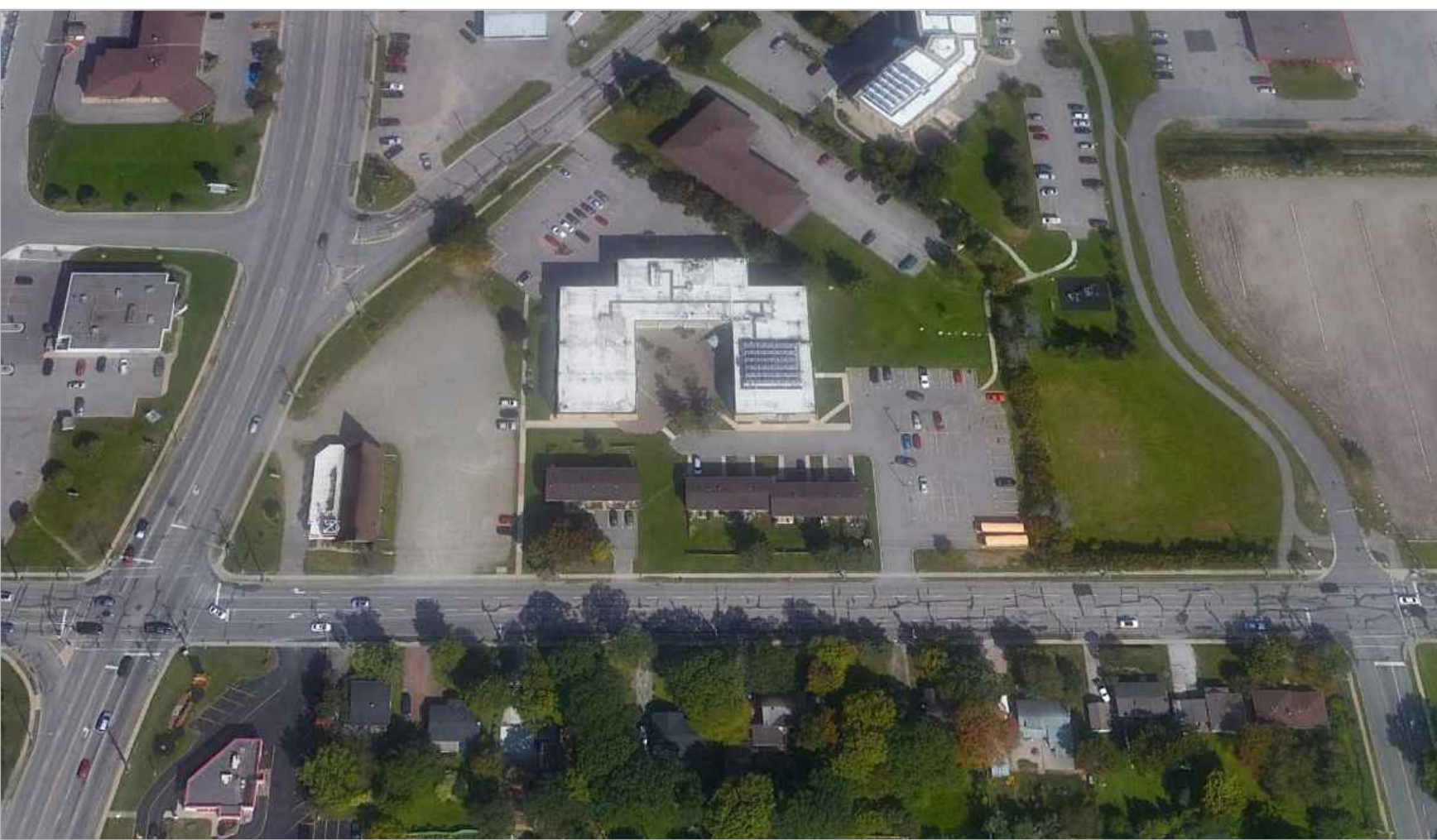
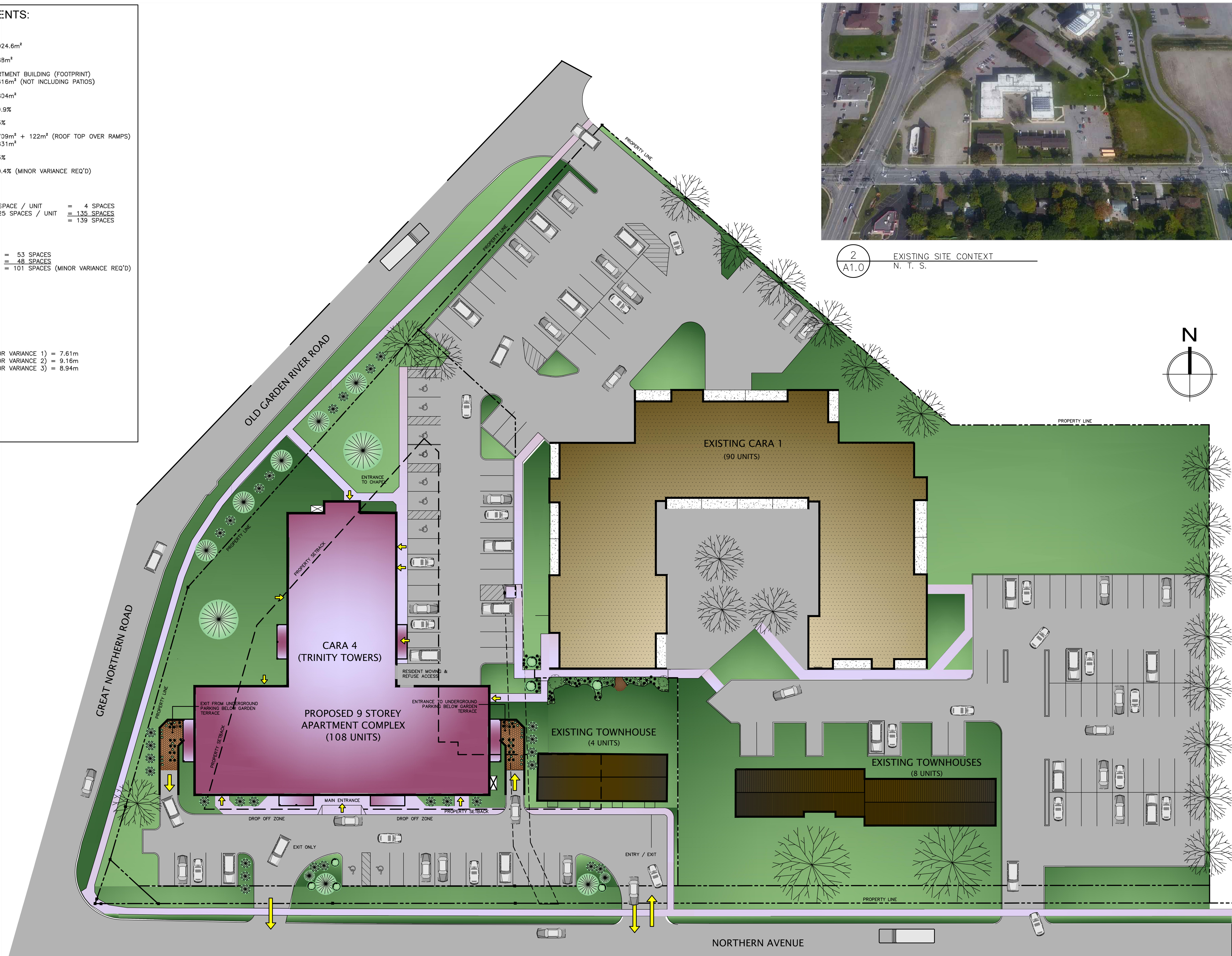

2  
A1.0 EXISTING SITE CONTEXT  
N. T. S.

1  
A1.0 OVERALL SITE PLAN  
N. T. S.



architects + engineer inc.

123 East Street  
Sault Ste. Marie, ON  
P6A 3C7

705.942.9494  
www.mgp-arch-eng.ca

**NOTES:**

ALL MEASUREMENTS ARE TO BE CONFIRMED ON SITE BY THE CONTRACTOR. ERRORS AND OMISSIONS ARE TO BE REPORTED TO THE ARCHITECT OR ENGINEER PRIOR TO PROCEEDING WITH WORK. RESPONSIBILITY FOR COORDINATION OF ALL WORK REMAINS WITH THE GENERAL CONTRACTOR. THIS WORK IS COPYRIGHT TO MGP ARCHITECTS + ENGINEERS INC. AND IS NOT TO BE COPIED OR REPRODUCED WITHOUT PERMISSION.

REV:	DESCRIPTION:	DATE:
STATUS:		
ISSUED FOR REVIEW		

PRELIMINARY  
DRAWINGS  
  
NOT FOR  
CONSTRUCTION

PROJECT:	TRINITY TOWERS 9-STOREY APARTMENT CARA COMMUNITY CORPORATION	CLIENT:	CARA COMMUNITY CORP 380 NORTHERN AVENUE
		LOCATION:	380 NORTHERN AVENUE SAULT STE. MARIE, ON

KEY PLAN:  
REV 1: +3 H/C SPACES

DRAWING TITLE:  
GENERAL SITE PLAN

SCALE:	DATE:	DRAWN:
N.T.S.	05/16/23	HAP
PROJECT NUMBER:	DRAWING NUMBER:	
.....		
DWG FILE:	A1.0	
SITE PLAN		

P:\2023\230749 - Northern Ave Apartment Building\04 Drawings\02 - Civil\230749 2023-05-30 KTN -C2 (Rev3).dwg

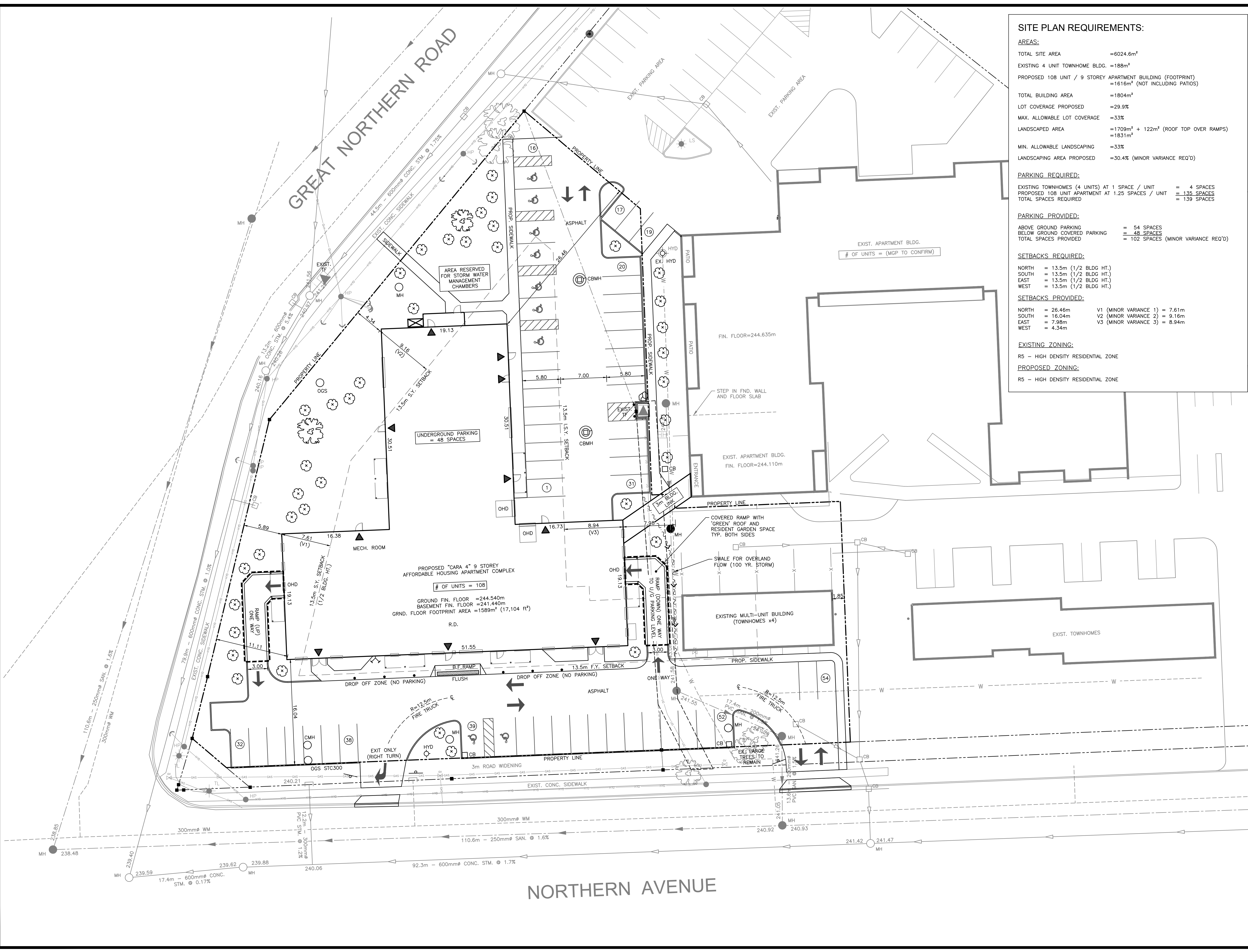

**SITE PLAN REQUIREMENTS:**

**AREAS:**

TOTAL SITE AREA	=6024.6m <sup>2</sup>
EXISTING 4 UNIT TOWNHOME BLDG.	=188m <sup>2</sup>
PROPOSED 108 UNIT / 9 STOREY APARTMENT BUILDING (FOOTPRINT)	=1616m <sup>2</sup> (NOT INCLUDING PATIOS)
TOTAL BUILDING AREA	=1804m <sup>2</sup>
LOT COVERAGE PROPOSED	=29.9%
MAX. ALLOWABLE LOT COVERAGE	=33%
LANDSCAPED AREA	=1709m <sup>2</sup> + 122m <sup>2</sup> (ROOF TOP OVER RAMPS)
	=1831m <sup>2</sup>
MIN. ALLOWABLE LANDSCAPING	=33%
LANDSCAPING AREA PROPOSED	=30.4% (MINOR VARIANCE REQ'D)

**PARKING REQUIRED:**

EXISTING TOWNHOMES (4 UNITS) AT 1 SPACE / UNIT	= 4 SPACES
PROPOSED 108 UNIT APARTMENT AT 1.25 SPACES / UNIT	= 135 SPACES
TOTAL SPACES REQUIRED	= 139 SPACES

**PARKING PROVIDED:**

ABOVE GROUND PARKING	= 54 SPACES
BELOW GROUND COVERED PARKING	= 48 SPACES
TOTAL SPACES PROVIDED	= 102 SPACES (MINOR VARIANCE REQ'D)

**SETBACKS REQUIRED:**

NORTH	= 13.5m (1/2 BLDG HT.)
SOUTH	= 13.5m (1/2 BLDG HT.)
EAST	= 13.5m (1/2 BLDG HT.)
WEST	= 13.5m (1/2 BLDG HT.)

**SETBACKS PROVIDED:**

NORTH	= 26.46m	V1 (MINOR VARIANCE 1) = 7.61m
SOUTH	= 16.04m	V2 (MINOR VARIANCE 2) = 9.16m
EAST	= 7.98m	V3 (MINOR VARIANCE 3) = 8.94m
WEST	= 4.34m	

**EXISTING ZONING:**  
R5 - HIGH DENSITY RESIDENTIAL ZONE

**PROPOSED ZONING:**  
R5 - HIGH DENSITY RESIDENTIAL ZONE

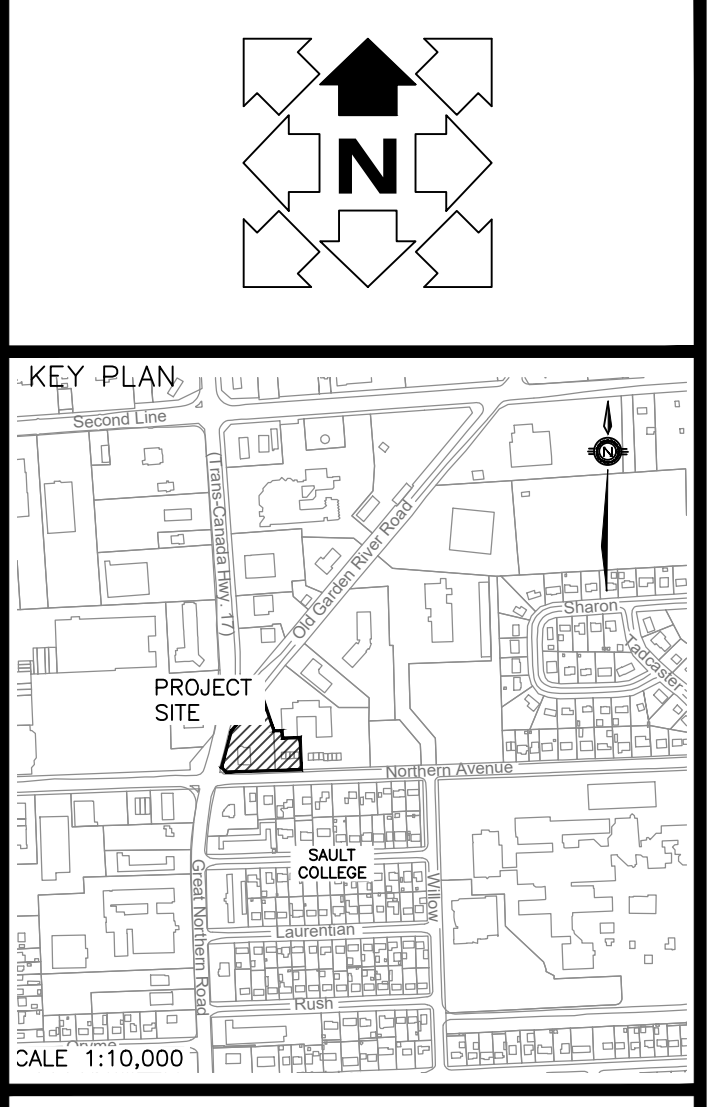

ENGINEER'S SEAL:

DATE	REV.	REVISION	BY	APP'D
2023.05.31	3	ISSUED FOR SITE PLAN CONTROL AMENDMENT	KTN	JVM
2023.05.08	2	SITE PLAN AMENDMENT #2	KTN	JVM
2023.04.11	1	SITE PLAN AMENDMENT #1	KTN	JVM
2023.04.06	0	ISSUED FOR CLIENT COMMENTS	KTN	JVM

CLIENT:

**CARA COMMUNITY CORP.**  
SAULT STE. MARIE, ON

CONSULTANT:

PROJECT TITLE:

**'CARA 4' TRINITY TOWERS  
9 STOREY  
APARTMENT COMPLEX  
360 NORTHERN AVENUE**

DRAWING TITLE:

**SITE PLAN  
AMENDMENT PLAN**

KTN	KN / JM	JVM	JVM
DRAWN	DESIGNED	CHECKED	APPROVED
1:250		MAY 31, 2023	
SCALE		DATE	
230749	3	C2	
PROJECT No.	REVISION	DRAWING	



**Breakdown of Units:**  
One Bedroom Units = 39  
Two Bedroom Units = 69  
Total = 108

**Breakdown of BF Units:**  
BF One Bedroom Units = 8  
BF Two Bedroom Units = 14  
Total = 22

**Breakdown of Units:**  
One Bedroom Units = 39  
Two Bedroom Units = 69  
Total = 108

**Breakdown of BF Units:**  
BF One Bedroom Units = 8  
BF Two Bedroom Units = 14  
Total = 22



**Breakdown of Units:**  
One Bedroom Units = 39  
Two Bedroom Units = 69  
Total = 108

**Breakdown of BF Units:**  
BF One Bedroom Units = 8  
BF Two Bedroom Units = 14  
Total = 22





# PRELIMINARY STORMWATER MANAGEMENT REPORT

## CARA IV 9 Storey Apartment Complex

MAY 2023  
TULLOCH Project #: 23-0749



## DISTRIBUTION LIST

# of Hard Copies	PDF Required	Association / Company Name
2	1	The Corporation of the City of Sault Ste. Marie

## REVISION LOG

Revision #	Revised By	Date	Issue / Revision Description
0	BG	May 24, 2023	Issued for Site Plan Control

## TULLOCH SIGNATURES

Report Prepared By:



John V. McDonald P. Eng.  
 Project Manager



## STATEMENT OF QUALIFICATIONS AND LIMITATIONS

The attached Report (the “Report”) has been prepared by Tulloch Engineering Inc. (“Consultant”) for the benefit of the client (“Client”) in accordance with the agreement between Consultant and Client, including the scope of work detailed therein (the “Agreement”).

The information and data contained in the Report:

- are subject to the scope, schedule, and other constraints and limitations in the Agreement and the qualifications contained in the Report (the “Limitations”)
- represent Consultant’s professional judgement in light of the Limitations and industry standards for the preparation of similar reports
- may be based on information provided to Consultant which has not been independently verified
- have not been updated since the date of issuance of the Report and their accuracy is limited to the time period and circumstances in which they were collected, processed, made or issued
- must be read as a whole and sections thereof should not be read out of such context
- were prepared for the specific purposes described in the Report and the Agreement
- in the case of subsurface, environmental or geotechnical conditions, may be based on limited testing and on the assumption that such conditions are uniform and not variable either geographically or over time

Unless expressly stated to the contrary in the Report or the Agreement, Consultant:

- shall not be responsible for any events or circumstances that may have occurred since the date on which the Report was prepared or for any inaccuracies contained in information that was provided to Consultant
- agrees that the Report represents its professional judgement as described above for the specific purpose described in the Report and the Agreement, but Consultant makes no other representations with respect to the Report or any part thereof
- in the case of subsurface, environmental or geotechnical conditions, is not responsible for variability in such conditions geographically or over time

The Report is to be treated as confidential and may not be used or relied upon by third parties, except:

- as agreed by Consultant and Client
- as required by law
- for use by governmental reviewing agencies

Any use of this Report is subject to this Statement of Qualifications and Limitations. Any damages arising from improper use of the Report or parts thereof shall be borne by the party making such use.

This Statement of Qualifications and Limitations is attached to and forms part of the Report.





## Table of Contents

1.	Introduction	1
1.1	General	1
1.2	Existing Conditions	1
1.3	Stormwater Management Approach	2
1.4	Design Criteria	2
1.5	Hydrologic Modelling	3
2.	Stormwater Management	3
2.1	Pre-Development Conditions	3
2.2	Post-Development Conditions	4
2.2.1	Quality Control	6
2.2.2	Temporary Storage	6
2.3	Pre- and Post-Development Flows	8
3.	Operation and Maintenance	8
4.	Report Limitations and Guidelines for use	9
5.	Closure	9

## LIST OF FIGURES

Figure 1.1. Site Location	1
---------------------------	---

## LIST OF TABLES

Table 2.1. Pre-Development Input Parameters	3
Table 2.2. Pre-Development Runoff Flows	4
Table 2.3. Post-Development Input Parameters	5
Table 2.4. Post-Development Unattenuated Peak Runoff Flows	5
Table 2.5. Area 201 Orifice Control Structures; Design Parameters	6
Table 2.6. Area 202 Orifice Control Structures; Design Parameters	7
Table 2.7. Post-Development Attenuated Peak Flows	7
Table 2.8. Area 201 Chamber Stage – Storage Relationship	8
Table 2.9. Area 202 Chamber Stage – Storage Relationship	8
Table 2.10. Summary of Pre- and Post – Development Total Peak Flows	8

## LIST OF APPENDICES

APPENDIX A.	Pre-Development Drainage Areas
APPENDIX B.	Post-Development Drainage Areas
APPENDIX C.	Hydrograph Results
APPENDIX D.	Stormceptor and StormTech Design Information and Maintenance Manuals

## 1. INTRODUCTION

### 1.1 General

TULLOCH was retained by Sal-Dan Construction Group (the Client) to prepare a Preliminary Stormwater Management Report in obtaining site plan control approved for support of the proposed 9-Storey Apartment Complex development at 352 Northern Avenue East in the City of Sault Ste. Marie, Ontario. A functional Stormwater Management Plan will need to be prepared with detailed design. The location of the property is shown in **Figure 1.1**.

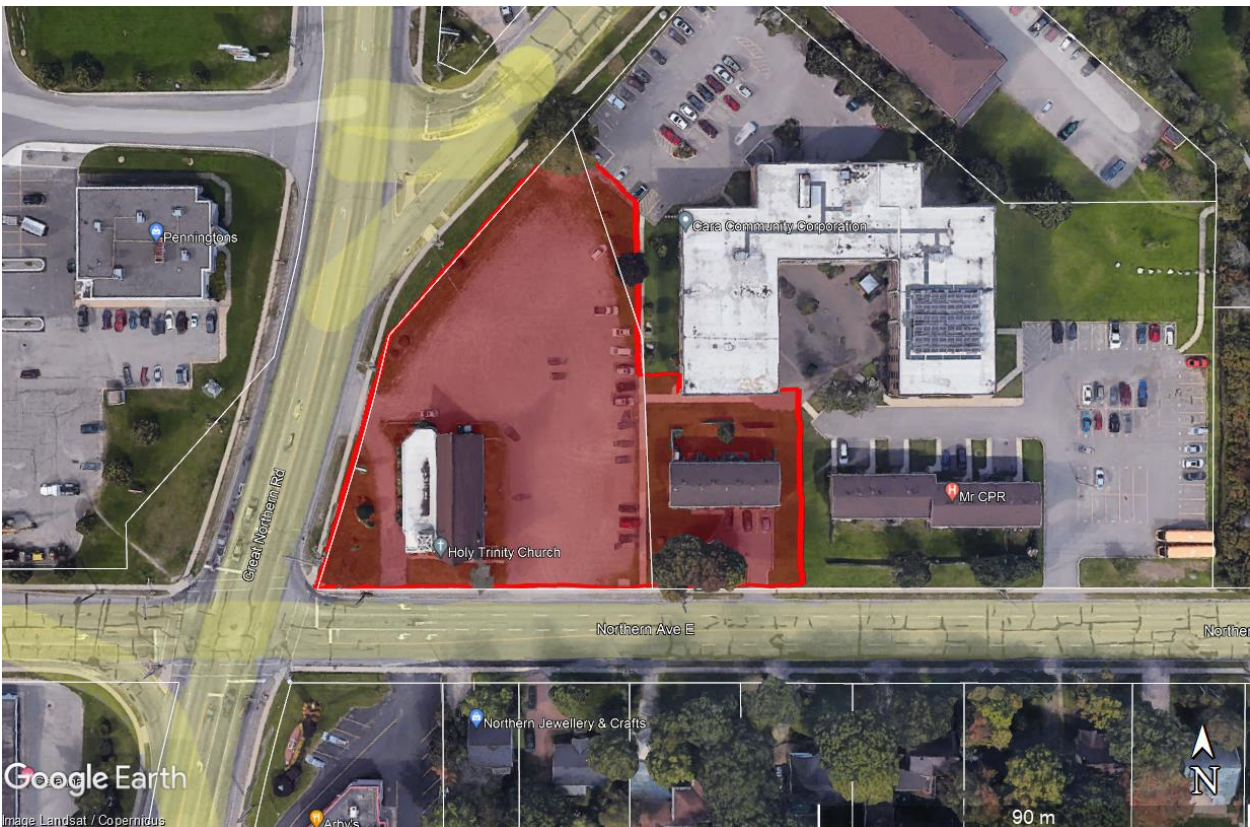

Figure 1.1. Site Location

### 1.2 Existing Conditions

At present, the site contains Holy Trinity Church and a 4-unit townhouse, and has an approximate area of 0.61 hectares. The existing property consists mostly of buildings, a small asphalt parking lot, a large gravel parking lot, and a number of small grassy areas.

The existing drainage area was split into six (6) distinct subcatchment areas, as shown in **Appendix A**. The stormwater runoff from the site generally drains to the southwest corner where it converges within the Great Northern Road/Northern Avenue underground drainage system.

Both the Old Garden River Road/Great Northern Road and Northern Avenue drainage systems drain to the southwest where they converge at the intersection of the two streets. The existing site does not manage stormwater, besides the infiltration through pervious surfaces, prior to entering the stormwater system.

In accordance with the geotechnical report in support of this project, surficial native soils for the study area generally consist of approximately 0.10 m of topsoil and grass followed by 0.60 m of stiff reddish-brown clay and then 0.40 m of gravelly sand. Lastly, a dense layer of sand and silt exists below the gravelly sand. The hydrologic soil group is estimated to be 'C'.

### **1.3 Stormwater Management Approach**

The stormwater management design for the proposed development is intended to replicate the existing drainage patterns on site to the furthest extent possible, and to meet the City of Sault Ste. Marie and the Sault Ste. Marie Region Conservation Authority's criteria for Stormwater Management. This will be accomplished as follows:

- The site will be modelled using various catchment areas that specifically focus on the drainage direction of that catchment and the intended stormwater discharge location;
- Run-off directions will be maintained as best as possible from pre-development to post-development conditions;
- Utilize underground storage for the quantity management of stormwater flows; and,
- Water quality objectives will be achieved via two (2) oil and grit separators.

### **1.4 Design Criteria**

The City of Sault Ste. Marie's design criteria for stormwater management is summarized as follows:

- Post-development peak flows cannot exceed pre-development peak flows;
- Quality control of stormwater runoff flows must ensure a minimum of 70% TSS removal;
- The design of stormwater management facilities must be in general conformance to the criteria stipulated in the Ontario Ministry of Environment, Conservation and Parks "Stormwater Management Planning and Design Manual" (March 2003); and,
- The design of stormwater management facilities must be in general conformance to the criteria stipulated in the City of Sault Ste. Marie's Stormwater Management Guidelines, Appendix K – City of Sault Ste. Marie Stormwater Investigation Study (July 2013).

## 1.5 Hydrologic Modelling

Hydrologic Modelling of the proposed development was conducted utilizing Visual OTTHYMO, Version 6.1 software. The OTTHYMO model is an updated version of the original HYMO model developed by the United States Department of Agriculture in the early 1970's. HYMO and its updated versions, including OTTHYMO are in use throughout North America and the world for hydrologic modelling of rural and urban watersheds.

In accordance with the City of Sault Ste. Marie, Stormwater Management Guidelines, an AES Type II, 1 hr. storm distribution was used to develop 2, 5, 10, 25, 50, and 100-year runoff hydrographs employing the Standard Hydrograph method.

Section 2.1 and Section 2.2 presents the OTTHYMO input parameters such as Curve Number (CN) values, impervious levels and initial abstraction calculations.

## 2. STORMWATER MANAGEMENT

### 2.1 Pre-Development Conditions

The parameters utilized in the OTTHYMO model for the subcatchment areas are displayed in **Table 2.1**.

**Table 2.1. Pre-Development Input Parameters**

Parameter	Pre-Development					
	Area 101	Area 102	Area 103	Area 104	Area 105	Area 106
Drainage Area	0.10 ha	0.06 ha	0.31 ha	0.03 ha	0.04 ha	0.07 ha
Total Imperviousness %	37%	75%	1.6%	99%	0.1%	27%
Directly connected % Imperviousness	0.001	0.001	0.001	0.001	0.001	0.001
Pervious Area						
• Curve Number	93	96	89	98	90	92
• Initial Abstraction	1.9 mm	1.05 mm	3.13 mm	0.5 mm	2.82 mm	2.2 mm
• Average Slope	1.0%	2.0%	3.6%	2.0%	1.0%	4.8%

• Average Length	33 m	7 m	100 m	16 m	29.99 m	25 m
Impervious Area						
Initial Abstraction	1.5 mm	1.5 mm	1.5 mm	1.5 mm	1.5 mm	1.5 mm
Slope	1.0 %	1.0%	1.0%	1.0%	1.0 %	1.0%
Length*	25.82 m	20 m	45.46 m	14.14 m	16.33 m	21.6 m
* Length of Impervious Area was calculated utilizing the formula “Area=1.5x(Length of Impervious Area)” where drainage area is in square meters – in accordance with OTTHYMO recommendations.						

The model of the pre-development conditions produced peak runoff flow estimates which are presented in **Table 2.2**.

**Table 2.2. Pre-Development Runoff Flows**

Catchment ID	Pre-Development Peak Runoff (L/s)					
	Return Period Storm (1hr AES)					
	2	5	10	25	50	100
1	5	9	12	16	19	22
2	10	14	16	20	22	25
3	5	11	15	22	28	34
4	6	8	9	11	12	13
5	1	2	3	4	5	6
6	4	7	9	12	15	18
<b>Combined (1-6)</b>	<b>19</b>	<b>32</b>	<b>43</b>	<b>56</b>	<b>72</b>	<b>83</b>

Please refer to **Appendix C** for OTTHYMO pre-development hydrograph results.

## 2.2 Post-Development Conditions

There are two (2) distinct post-development subcatchment areas, as shown in **Appendix B**, totaling an approximate area of 0.61 ha. Runoff from Area 202 is conveyed northwest of the site where it is to be attenuated by means of temporary storage discussed further in Section 2.2.2, prior to entering the Great Northern Road municipal storm sewer system. The runoff from Area 201 is conveyed towards the southwest portion of the property where it is also attenuated by means of temporary storage, prior to entering the Northern Avenue municipal storm sewer.

Overland flow is generally conveyed to the southwest corner of the property towards the larger of the two underground stormwater facilities, before draining onto Northern Avenue.

The hydrologic parameters utilized in the OTTHYMO model for the post-development drainage areas are as indicated in **Table 2.3**.

**Table 2.3. Post-Development Input Parameters**

Parameter	Post-Development	
	201	202
Drainage Area	0.40 ha	0.21 ha
Total % Imperviousness	81%	54%
Directly connected % Imperviousness	81%	54%
Pervious Area		
• Curve Number	96	94
• Initial Abstraction	1.05 mm	1.62 mm
• Average Slope	2.0%	2.0%
• Average Length	30 m	40 m
Impervious Area		
Initial Abstraction	1.5 mm	1.5 mm
Slope	2.0%	2.0%
Length*	51.64	37.42
* Length of Impervious Area was calculated utilizing the formula “Area=1.5x(Length of Impervious Area)” where drainage area is in square meters – in accordance with OTTHYMO recommendations.		

Displayed below are the post-development peak runoff flows without attenuation.

**Table 2.4. Post-Development Unattenuated Peak Runoff Flows**

		Post-Development Unattenuated Peak Runoff (L/s)					
		Return Period Storm (1hr AES)					
Catchment ID	Outlet	2	5	10	25	50	100
Area 201	Northern Ave. / Great Northern Rd.	65	94	112	134	151	167
Area 202	Great Northern Rd.	23	32	40	49	55	62
<b>Combined</b>	<b>Northern Ave.</b>	<b>88</b>	<b>126</b>	<b>152</b>	<b>183</b>	<b>206</b>	<b>229</b>

### 2.2.1 Quality Control

Quality control of the site run-off to meet the minimum requirements (70% removal of total suspended solids (TSS)) will be provided for the proposed development by means of two (2) Stormceptor EF4 Oil Grit Separator (OGS) or equivalent. The runoff from the site will be collected and conveyed into two (2) underground stormwater storage facilities with orifice-controlled release, and then enter the Oil Grit Separators which will achieve a minimum of 70% TSS removal for Area 201 and 70% TSS removal for Area 202. The reduction of post-development flows to pre-development levels will be achieved through the implementation of a combination of flow restriction methods and runoff volume storage.

### 2.2.2 Quantity Control Storage

The reduction of post-development flows to pre-development levels will be achieved through the implementation of a combination of flow restriction methods and runoff volume storage. Temporary storage of stormwater on the property will be achieved by underground stormwater storage facilities while utilizing orifice-controlled release. The underground storage will consist of two (2) underground stormwater storage facilities (28 MC-3500 Series StormTech Chambers, or equal equivalent), located at both the northwest and southwest corner of the site.

Series StormTech Chambers or equivalent are to be located in the southwest corner of the site to attenuate the stormwater runoff for Area 201. 8 MC-3500 Series StormTech Chambers or approved equivalent are to be located in the northwest corner of the site to attenuate the stormwater runoff for Area 202.

Orifice control structures will be installed adjacent to the underground stormwater storage facilities to regulate stormwater flows to pre-development conditions or less.

Preliminary Design Parameters for the storage control structure are displayed in **Table 2.5**.

**Table 2.5. Area 201 Orifice Control Structures; Design Parameters**

Design Parameter	Dimension
Orifice 1 Diameter	75 mm
Orifice 1 Invert Elevation	0.0 m *
Orifice 2 Diameter	100 mm
Orifice 2 Invert Elevation	0.8 m *
Orifice 3 Diameter	150 mm
Orifice 3 Invert Elevation	1.2 m *
Wier Width	0.8 m
Wier Elevation	1.5 m *



\* Elevation from bottom of the chambers

**Table 2.6. Area 202 Orifice Control Structures; Design Parameters**

Design Parameter	Dimension
Orifice 1 Diameter	75 mm
Orifice 1 Invert Elevation	0.0 m *
Orifice 2 Diameter	75 mm
Orifice 2 Invert Elevation	0.8 m *
Wier Width	0.8 m
Wier Elevation	1.5 m *

\* Elevation from bottom of the chambers

Based on the above design parameters, **Table 2.7** presents the expected controlled stormwater flows as a result of the development. Please refer to **Appendix C** for OTTHYMO post-development hydrograph results.

**Table 2.7. Post-Development Attenuated Peak Flows**

		Post-Development Attenuated Peak Runoff (L/s)					
		Return Period Storm (1hr AES)					
Catchment ID	Outlet	2	5	10	25	50	100
Area 201	Northern Ave. / Great Northern Rd.	10	17	22	33	47	57
Area 202	Great Northern Rd.	8	10	14	18	21	23
<b>Combined</b>	<b>Northern Ave.</b>	<b>18</b>	<b>27</b>	<b>36</b>	<b>51</b>	<b>68</b>	<b>80</b>

**Table 2.7** presents the stage-storage relationship of the proposed underground stormwater storage.

**Table 2.8. Area 201 Chamber Stage-Storage Relationship**

Storm Event	Storage Chamber Depth (m)	Storage Chamber Volume (m <sup>3</sup> )
2-Year	0.643	45.43
5-Year	0.871	63.72
10-Year	1.01	74.0
25-Year	1.18	85.43
50-Year	1.27	90.43
100-Year	1.38	95.34

**Table 2.9. Area 202 Chamber Stage-Storage Relationship**

Storm Event	Storage Chamber Depth (m)	Storage Chamber Volume (m <sup>3</sup> )
2-Year	0.439	11.38
5-Year	0.664	19.17
10-Year	0.808	23.87
25-Year	0.993	29.55
50-Year	1.14	33.54
100-Year	1.31	37.43

### 2.3 Pre- and Post-Development Flows

**Table 2.10** presents a comparison between pre-development runoff flows versus post-development unattenuated and attenuated runoff flows.

**Table 2.10. Summary of Pre- and Post-Development Total Peak Flows**

Return Period	Total Peak Runoff (L/s)				
	Pre-Development Flow	Post-Development Unattenuated Flow	Change in Stormwater Flows	Post-Development Attenuated Flow	Change in Stormwater Flows
2-year	19	88	+ 69	18	-1
5-year	32	126	+ 94	27	-5
10-year	43	152	+ 109	36	-7
25-year	56	183	+ 127	51	-5
50-year	72	206	+ 134	68	-4
100-year	83	229	+ 146	80	-3

Given the proposed post-development flow attenuation we can reasonably conclude that feasible methods can be readily implemented to control, the total peak runoff to less than or equal to that of the pre-development runoff flows.

### 3. OPERATION AND MAINTENANCE

In addition to the manufacturer’s maintenance manual, maintenance with respect to stormwater drainage will consist of the following items:

- Remove parking lot sediment to ensure positive surface drainage;
- Keep the site clear of snow and ice dams to ensure drainage reaches its intended outlet and no ponding occurs; and,

- Repair damage to the parking surface (i.e. holes in asphalt/concrete) to ensure positive drainage off the site and away from the structure.
- The oil/grit separator will require that accumulated sediments and oil be removed on a regular basis. The maintenance of the oil/grit separator should follow the manufacturer's recommendations for the particular oil/grit separator installed.
- The StormTech chambers will require that accumulated sediments be removed on a regular basis. The maintenance of the StormTech chambers should follow the manufacturer's recommendations.

Operation and Maintenance manuals and recommendations are provided in **Appendix D** for the StormTech chambers as well as the Stormceptor.

#### **4. REPORT LIMITATIONS AND GUIDELINES FOR USE**

We have prepared this report for the exclusive use of Sal-Dan Construction Group and their authorized agents for the proposed development. The report is only applicable to the project described herein. Any changes to the project require a review by TULLOCH to ensure compatibility with the stormwater management system as described in this report.

#### **5. CLOSURE**

We trust that the information and recommendations in this report will be found to be complete and adequate for your consideration. Should further elaboration be required for any portion of this project, we would be pleased to provide assistance.

## **APPENDIX A**

---

### **Pre-Development Drainage Areas**

P:\2023\230749 Saldan - Northern Ave Apartment Building\Civil\04 Drawings\02 - Civil\230749 2023-05-16 SK1 - Pre-Dev.dwg

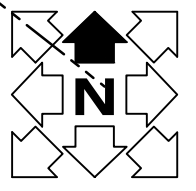

PRE-DEVELOPMENT CATCHMENT AREA LEGEND

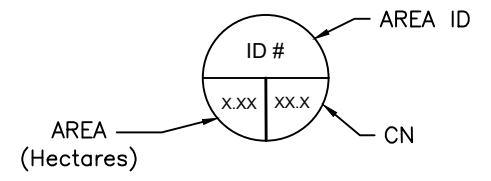

No.	DATE	BY	ISSUES / REVISIONS



DRAWING:  
**PRE-DEVELOPMENT  
CATCHMENT AREAS**

PROJECT:  
**'CARA 4' - 9 STOREY  
APARTMENT COMPLEX  
360 NORTHERN AVENUE**

DRAWN BY: TP	CHECKED BY: -	PROJECT No. : 230749
DESIGNED BY: BG	APPROVED BY: -	DRAWING No. : <b>SK1</b>
SCALE: AS NOTED	DATE: MAY. 15, 2023	REVISION No. : <b>0</b>

## **APPENDIX B**

---

### **Post-Development Drainage Areas**

P:\2023\230749 Saldan - Northern Ave Apartment Building\Civil\04 Drawings\02 - Civil\230749 2023-05-16 TP Areas.dwg

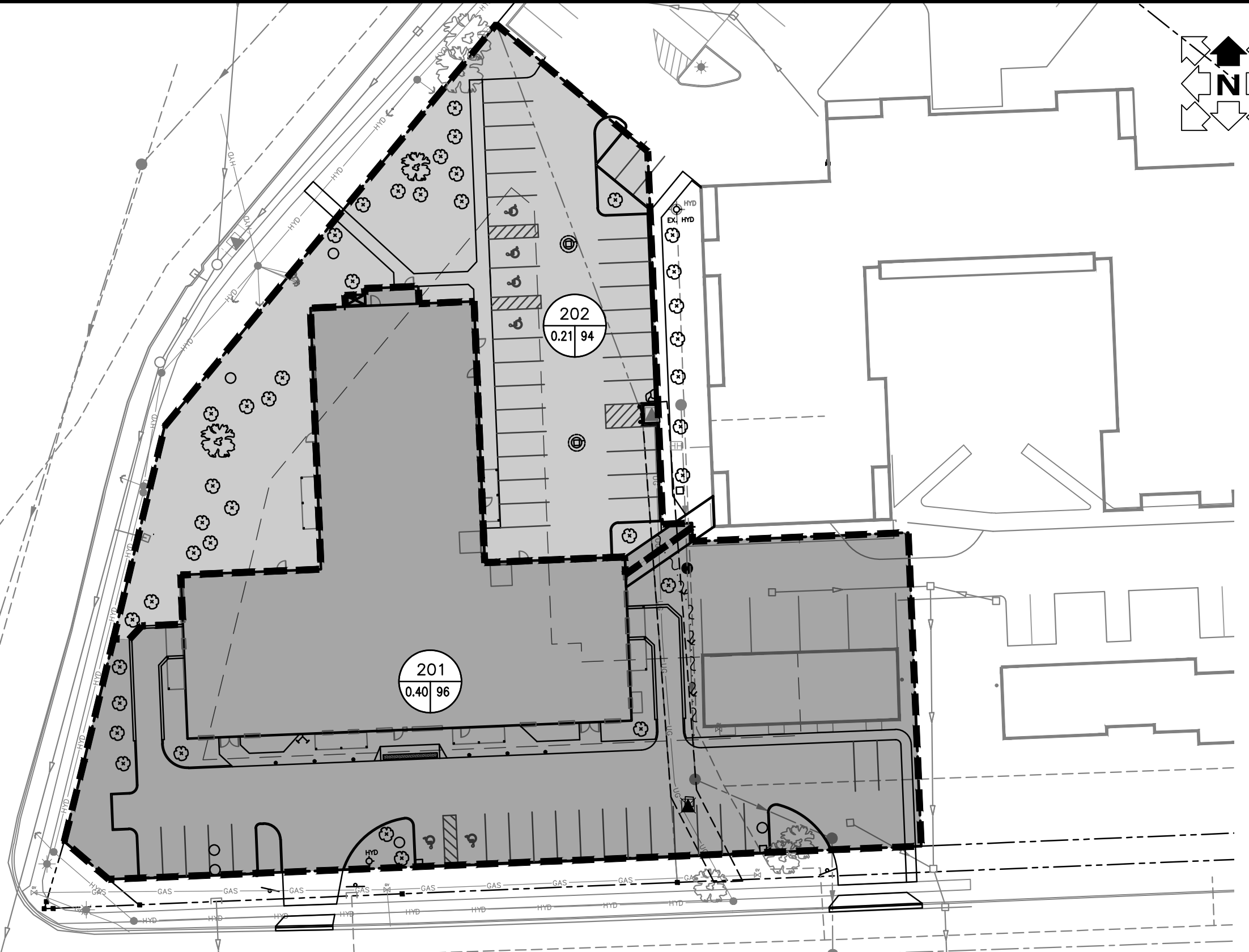
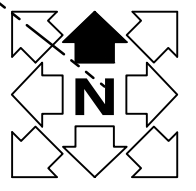

**POST-DEVELOPMENT CATCHMENT AREA LEGEND**

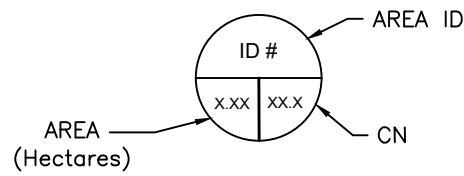

No.	DATE	BY	ISSUES / REVISIONS



DRAWING:  
**POST-DEVELOPMENT  
CATCHMENT AREAS**

PROJECT:  
**'CARA 4' - 9 STOREY  
APARTMENT COMPLEX  
360 NORTHERN AVENUE**

DRAWN BY: TP	CHECKED BY: -	PROJECT No. : 230749	REVISION No.:
DESIGNED BY: BG	APPROVED BY: -	DRAWING No. : <b>SK2</b>	0
SCALE: AS NOTED	DATE: MAY. 15, 2023		

## **APPENDIX C**

---

### **Hydrograph Results**



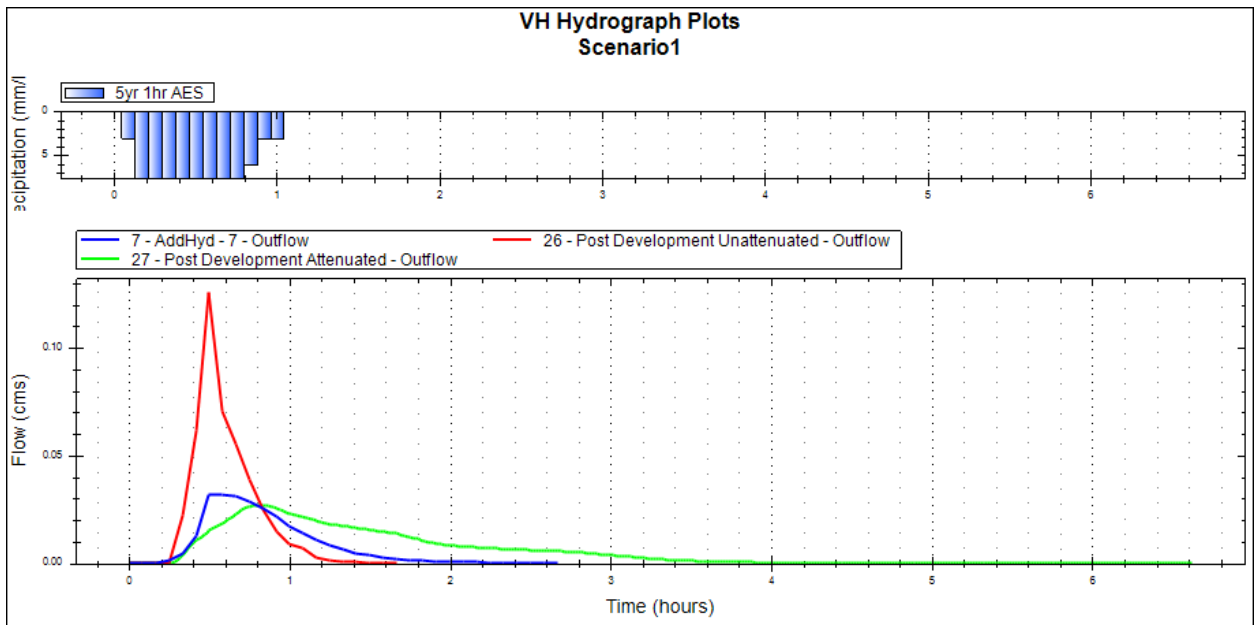
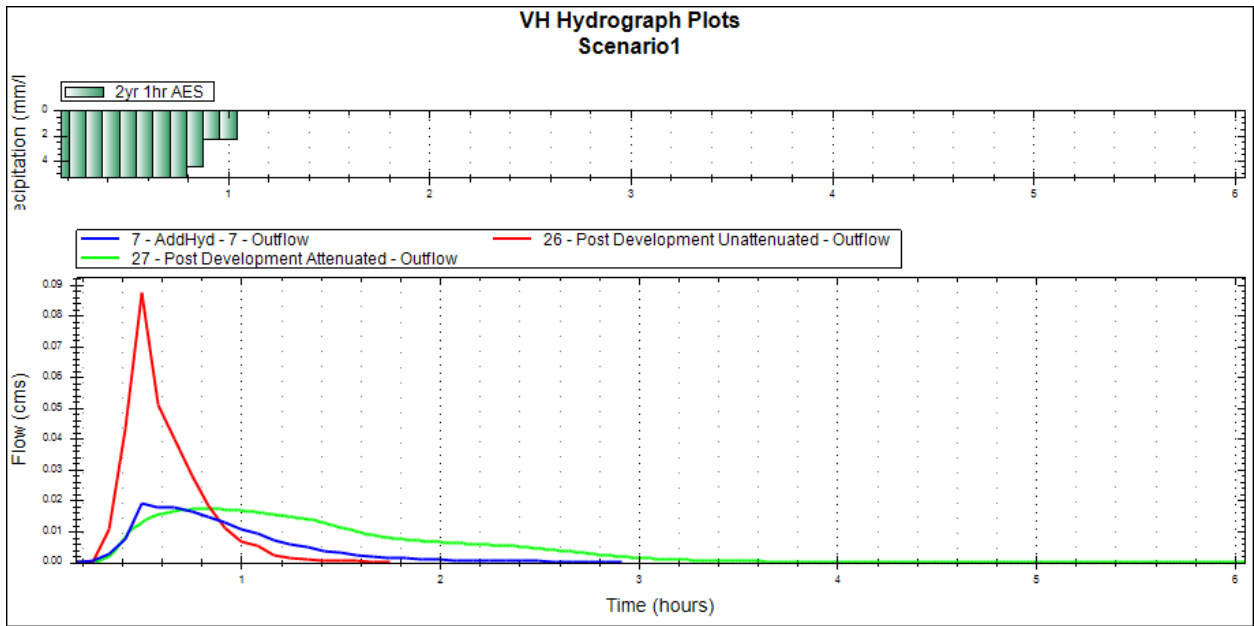

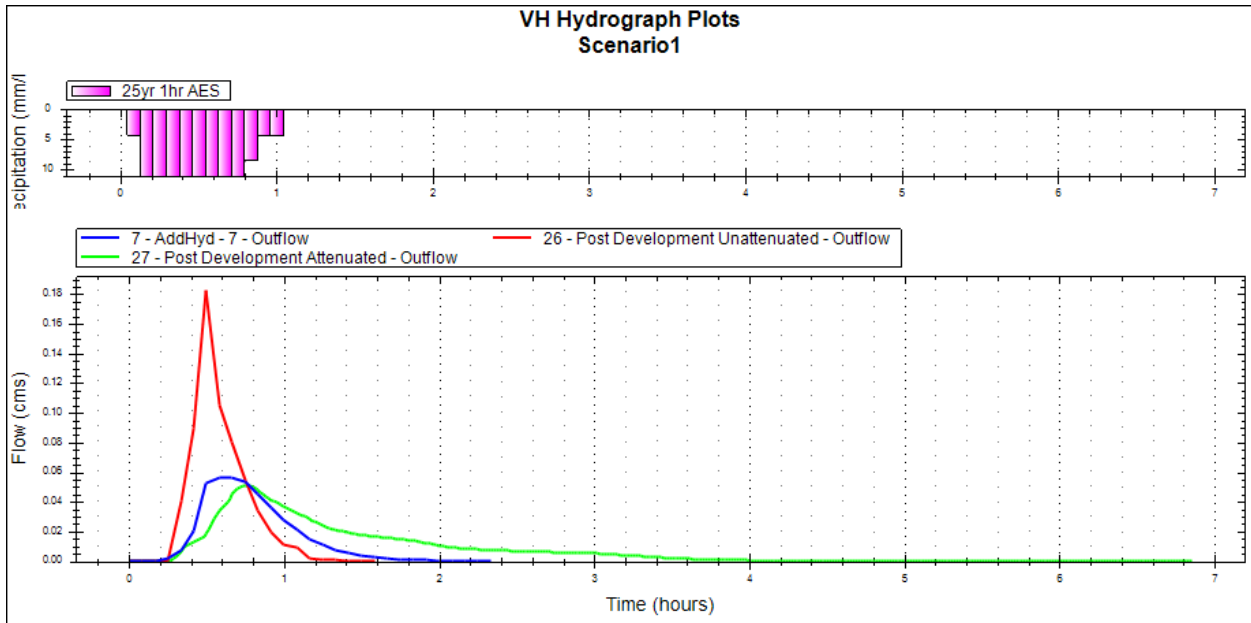
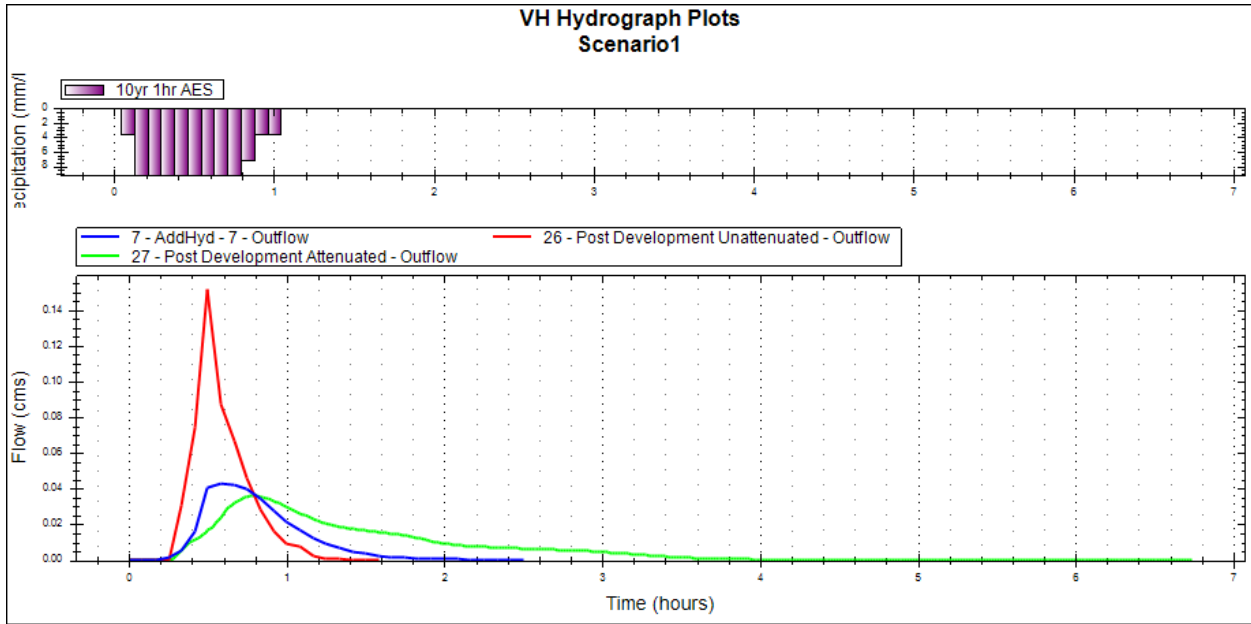

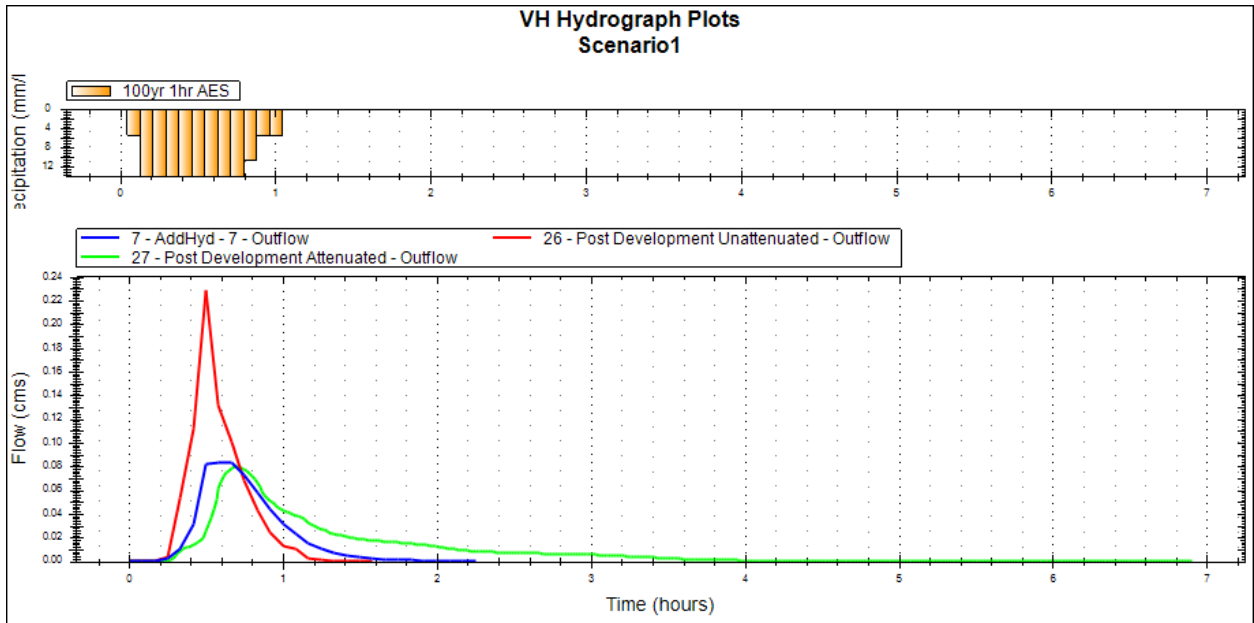
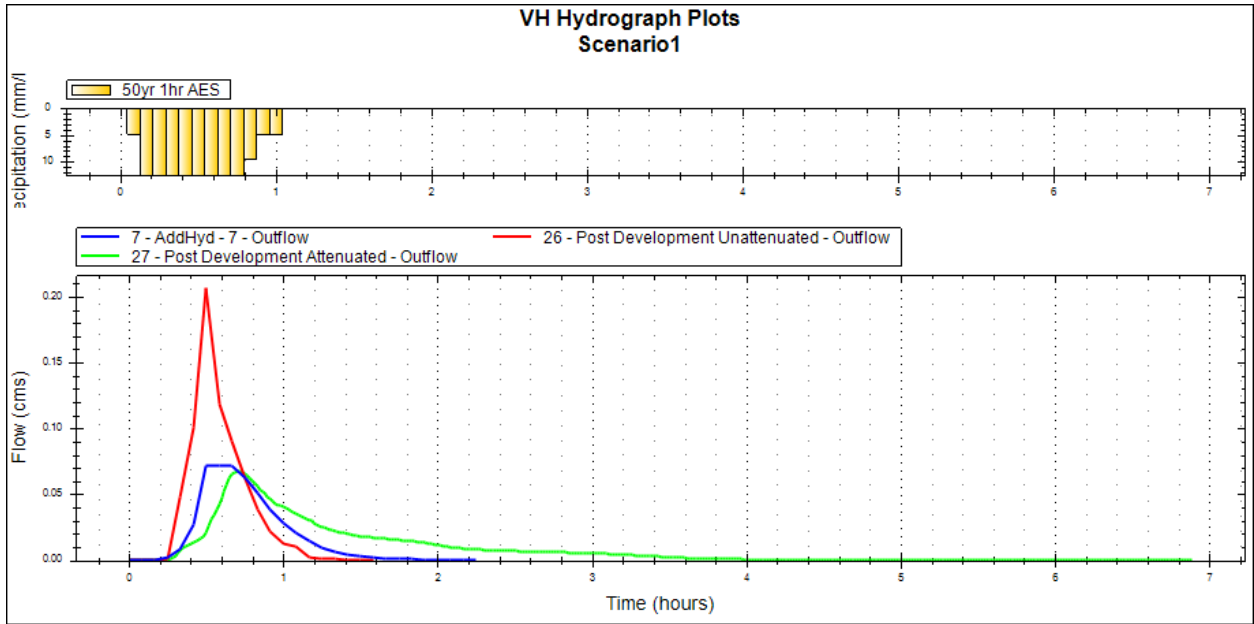

## **APPENDIX D**

---

### **Stormceptor and StormTech Design Information and Maintenance Manuals**

Stormceptor® EF Sizing Report

**STORMCEPTOR®**

**ESTIMATED NET ANNUAL SEDIMENT (TSS) LOAD REDUCTION**

05/24/2023

Province:	Ontario - Sault Ste Marie
City:	Sault Ste. Marie
Nearest Rainfall Station:	SAULT STE MARIE AP
Climate Station Id:	6057592
Years of Rainfall Data:	17

Project Name:	Cara IV Apartments
Project Number:	23-0749
Designer Name:	Brian Genua
Designer Company:	TULLOCH
Designer Email:	brian.genua@tulloch.ca
Designer Phone:	705-949-1457
EOR Name:	
EOR Company:	
EOR Email:	
EOR Phone:	

Site Name:	
------------	--

Drainage Area (ha):	0.61
% Imperviousness:	71.00

Runoff Coefficient 'c': 0.72

Particle Size Distribution:	Fine
Target TSS Removal (%):	70.0

Required Water Quality Runoff Volume Capture (%):	
Estimated Water Quality Flow Rate (L/s):	14.96
Oil / Fuel Spill Risk Site?	No
Upstream Flow Control?	No
Peak Conveyance (maximum) Flow Rate (L/s):	
Site Sediment Transport Rate (kg/ha/yr):	

Net Annual Sediment (TSS) Load Reduction Sizing Summary	
Stormceptor Model	TSS Removal Provided (%)
EF4	86
EF6	93
EF8	96
EF10	98
EF12	99

**Recommended Stormceptor EF Model: EF4**  
**Estimated Net Annual Sediment (TSS) Load Reduction (%): 86**  
**Water Quality Runoff Volume Capture (%): > 90**

## Stormceptor® EF Sizing Report

### THIRD-PARTY TESTING AND VERIFICATION

► **Stormceptor® EF and Stormceptor® EFO** are the latest evolutions in the Stormceptor® oil-grit separator (OGS) technology series, and are designed to remove a wide variety of pollutants from stormwater and snowmelt runoff. These technologies have been third-party tested in accordance with the Canadian ETV **Procedure for Laboratory Testing of Oil-Grit Separators** and performance has been third-party verified in accordance with the **ISO 14034 Environmental Technology Verification (ETV)** protocol.

### PERFORMANCE

► **Stormceptor® EF and EFO** remove stormwater pollutants through gravity separation and floatation, and feature a patent-pending design that generates positive removal of total suspended solids (TSS) throughout each storm event, including high-intensity storms. Captured pollutants include sediment, free oils, and sediment-bound pollutants such as nutrients, heavy metals, and petroleum hydrocarbons. Stormceptor is sized to remove a high level of TSS from the frequent rainfall events that contribute the vast majority of annual runoff volume and pollutant load. The technology incorporates an internal bypass to convey excessive stormwater flows from high-intensity storms through the device without resuspension and washout (scour) of previously captured pollutants. Proper routine maintenance ensures high pollutant removal performance and protection of downstream waterways.

### PARTICLE SIZE DISTRIBUTION (PSD)

► The **Canadian ETV PSD** shown in the table below was used, or in part, for this sizing. This is the identical PSD that is referenced in the Canadian ETV **Procedure for Laboratory Testing of Oil-Grit Separators** for both sediment removal testing and scour testing. The Canadian ETV PSD contains a wide range of particle sizes in the sand and silt fractions, and is considered reasonably representative of the particle size fractions found in typical urban stormwater runoff.

Particle Size (µm)	Percent Less Than	Particle Size Fraction (µm)	Percent
1000	100	500-1000	5
500	95	250-500	5
250	90	150-250	15
150	75	100-150	15
100	60	75-100	10
75	50	50-75	5
50	45	20-50	10
20	35	8-20	15
8	20	5-8	10
5	10	2-5	5
2	5	<2	5

Stormceptor® EF Sizing Report

Rainfall Intensity (mm / hr)	Percent Rainfall Volume (%)	Cumulative Rainfall Volume (%)	Flow Rate (L/s)	Flow Rate (L/min)	Surface Loading Rate (L/min/m <sup>2</sup> )	Removal Efficiency (%)	Incremental Removal (%)	Cumulative Removal (%)
0.5	9.4	9.4	0.62	37.0	31.0	100	9.4	9.4
1	20.9	30.3	1.23	74.0	62.0	100	20.9	30.3
2	15.8	46.1	2.46	148.0	123.0	93	14.8	45.1
3	10.1	56.3	3.69	222.0	185.0	86	8.7	53.8
4	8.2	64.4	4.92	295.0	246.0	81	6.6	60.4
5	6.8	71.2	6.16	369.0	308.0	78	5.3	65.7
6	3.9	75.1	7.39	443.0	369.0	75	2.9	68.6
7	3.5	78.7	8.62	517.0	431.0	73	2.6	71.2
8	3.4	82.0	9.85	591.0	492.0	72	2.4	73.7
9	2.8	84.8	11.08	665.0	554.0	72	2.0	75.7
10	1.6	86.4	12.31	739.0	616.0	71	1.1	76.8
11	2.0	88.5	13.54	813.0	677.0	70	1.4	78.3
12	1.3	89.8	14.77	886.0	739.0	70	0.9	79.2
13	1.4	91.2	16.00	960.0	800.0	69	1.0	80.2
14	0.2	91.4	17.24	1034.0	862.0	69	0.2	80.3
15	0.9	92.4	18.47	1108.0	923.0	68	0.6	80.9
16	1.0	93.4	19.70	1182.0	985.0	68	0.7	81.6
17	0.0	93.4	20.93	1256.0	1046.0	68	0.0	81.6
18	0.9	94.2	22.16	1330.0	1108.0	70	0.6	82.2
19	0.3	94.5	23.39	1404.0	1170.0	71	0.2	82.4
20	1.9	96.4	24.62	1477.0	1231.0	72	1.3	83.8
21	0.7	97.0	25.85	1551.0	1293.0	73	0.5	84.3
22	0.3	97.4	27.09	1625.0	1354.0	74	0.3	84.5
23	0.4	97.7	28.32	1699.0	1416.0	75	0.3	84.8
24	0.4	98.1	29.55	1773.0	1477.0	72	0.3	85.1
25	0.4	98.5	30.78	1847.0	1539.0	69	0.3	85.3
30	0.9	99.4	36.93	2216.0	1847.0	57	0.5	85.9
35	0.6	100.0	43.09	2585.0	2155.0	49	0.3	86.1
40	0.0	100.0	49.25	2955.0	2462.0	43	0.0	86.1
45	0.0	100.0	55.40	3324.0	2770.0	39	0.0	86.1
<b>Estimated Net Annual Sediment (TSS) Load Reduction =</b>								<b>86 %</b>

Climate Station ID: 6057592 Years of Rainfall Data: 17



Stormceptor® **EF** Sizing Report

**RAINFALL DATA FROM SAULT STE MARIE AP RAINFALL STATION**

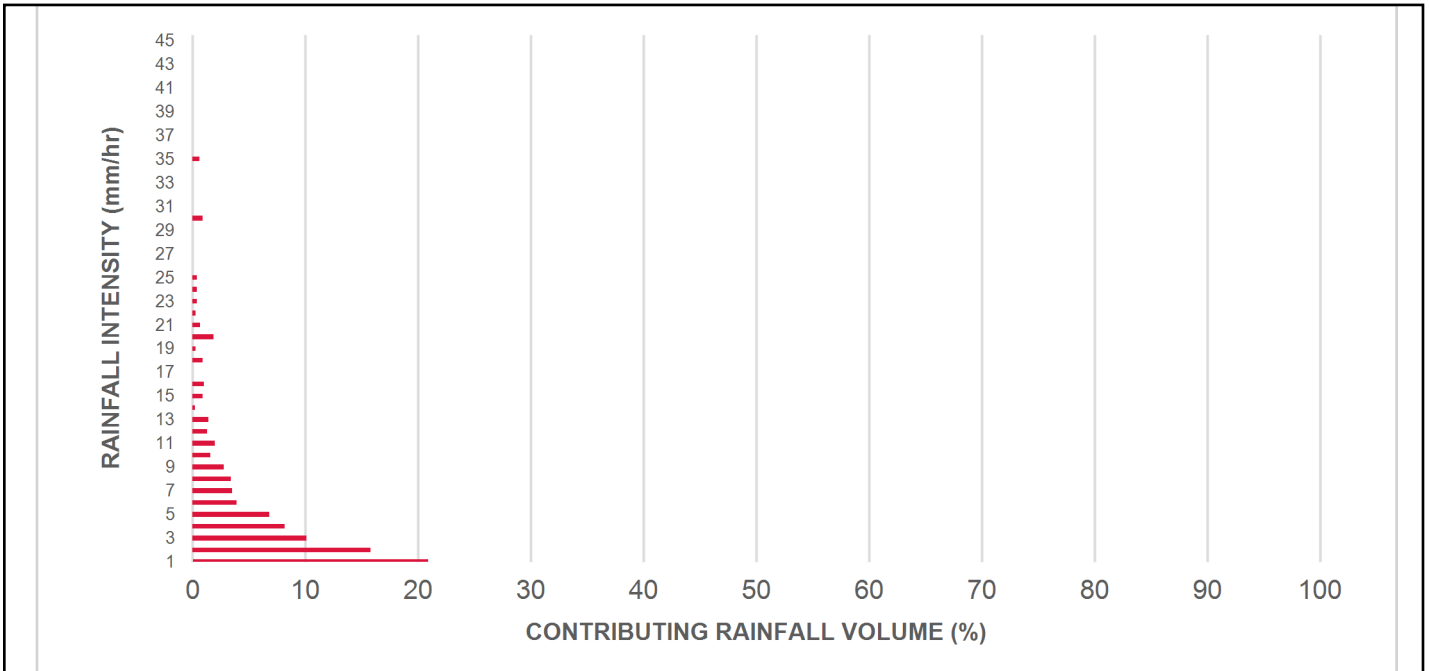

**INCREMENTAL AND CUMULATIVE TSS REMOVAL FOR THE RECOMMENDED STORMCEPTOR® MODEL**

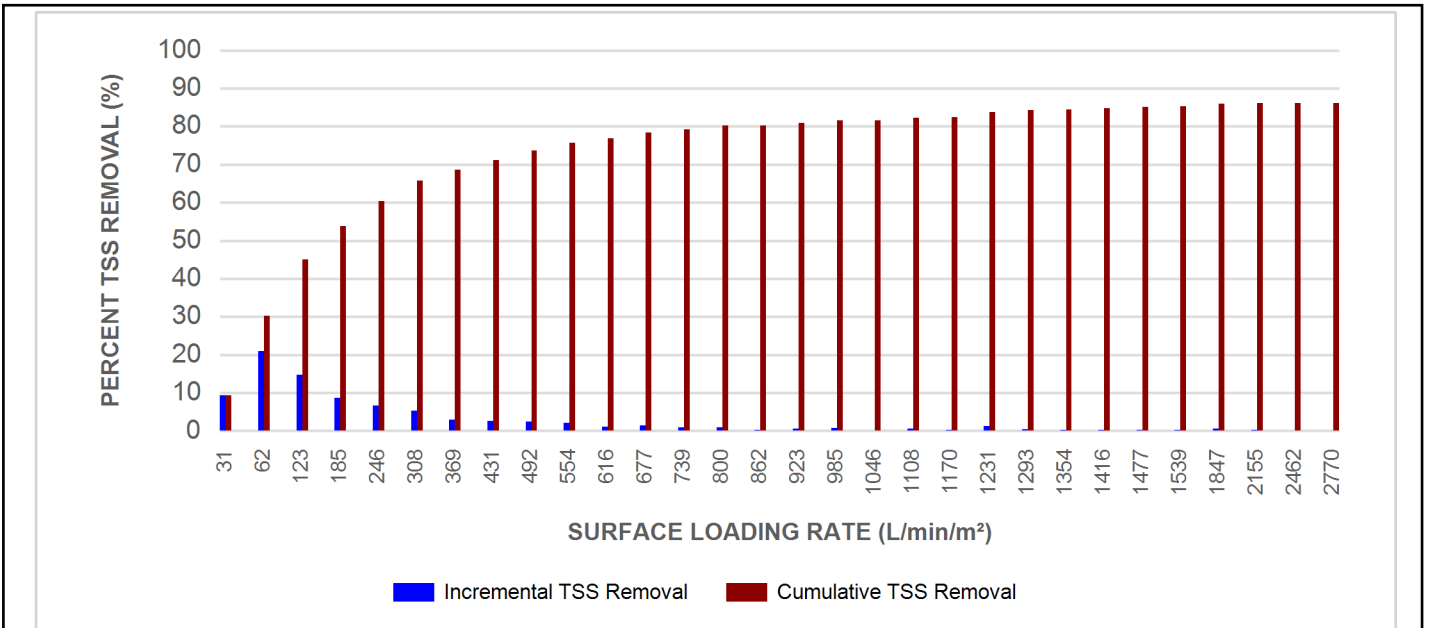



Stormceptor® **EF** Sizing Report

Maximum Pipe Diameter / Peak Conveyance

Stormceptor EF / EFO	Model Diameter		Min Angle Inlet / Outlet Pipes	Max Inlet Pipe Diameter		Max Outlet Pipe Diameter		Peak Conveyance Flow Rate	
	(m)	(ft)		(mm)	(in)	(mm)	(in)	(L/s)	(cfs)
EF4 / EFO4	1.2	4	90	609	24	609	24	425	15
EF6 / EFO6	1.8	6	90	914	36	914	36	990	35
EF8 / EFO8	2.4	8	90	1219	48	1219	48	1700	60
EF10 / EFO10	3.0	10	90	1828	72	1828	72	2830	100
EF12 / EFO12	3.6	12	90	1828	72	1828	72	2830	100

**SCOUR PREVENTION AND ONLINE CONFIGURATION**

► Stormceptor® EF and EFO feature an internal bypass and superior scour prevention technology that have been demonstrated in third-party testing according to the scour testing provisions of the Canadian ETV **Procedure for Laboratory Testing of Oil-Grit Separators**, and the exceptional scour test performance has been third-party verified in accordance with the ISO 14034 ETV protocol. As a result, Stormceptor EF and EFO are approved for online installation, eliminating the need for costly additional bypass structures, piping, and installation expense.

**DESIGN FLEXIBILITY**

► Stormceptor® EF and EFO offers design flexibility in one simplified platform, accepting stormwater flow from a single inlet pipe or multiple inlet pipes, and/or surface runoff through an inlet grate. The device can also serve as a junction structure, accommodate a 90-degree inlet-to-outlet bend angle, and can be modified to ensure performance in submerged conditions.

**OIL CAPTURE AND RETENTION**

► While Stormceptor® EF will capture and retain oil from dry weather spills and low intensity runoff, Stormceptor® EFO has demonstrated superior oil capture and greater than 99% oil retention in third-party testing according to the light liquid re-entrainment testing provisions of the Canadian ETV **Procedure for Laboratory Testing of Oil-Grit Separators**. Stormceptor EFO is recommended for sites where oil capture and retention is a requirement.

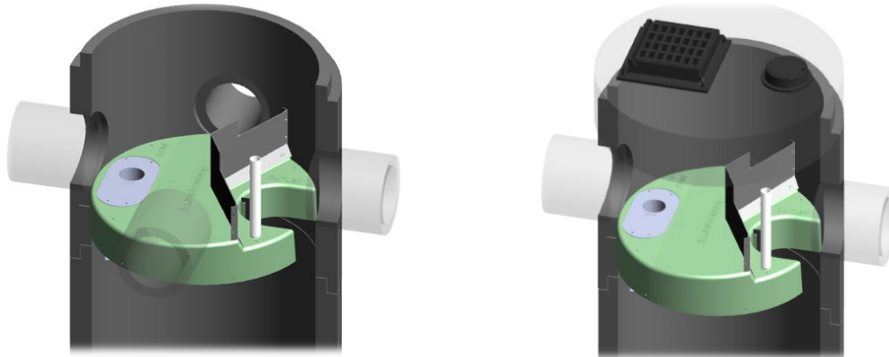

## Stormceptor® EF Sizing Report

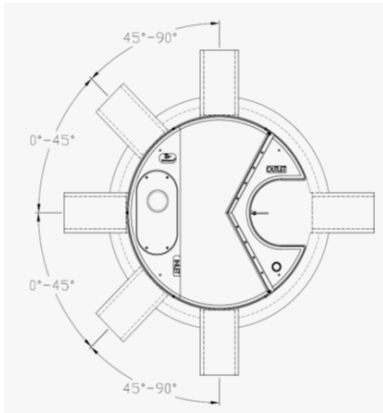

### INLET-TO-OUTLET DROP

Elevation differential between inlet and outlet pipe inverts is dictated by the angle at which the inlet pipe(s) enters the unit.

0° - 45° : The inlet pipe is 1-inch (25mm) higher than the outlet pipe.

45° - 90° : The inlet pipe is 2-inches (50mm) higher than the outlet pipe.

### HEAD LOSS

The head loss through Stormceptor EF is similar to that of a 60-degree bend structure. The applicable K value for calculating minor losses through the unit is 1.1.

For submerged conditions the applicable K value is 3.0.

### Pollutant Capacity

Stormceptor EF / EFO	Model Diameter		Depth (Outlet Pipe Invert to Sump Floor)		Oil Volume		Recommended Sediment Maintenance Depth *		Maximum Sediment Volume *		Maximum Sediment Mass **	
	(m)	(ft)	(m)	(ft)	(L)	(Gal)	(mm)	(in)	(L)	(ft³)	(kg)	(lb)
EF4 / EFO4	1.2	4	1.52	5.0	265	70	203	8	1190	42	1904	5250
EF6 / EFO6	1.8	6	1.93	6.3	610	160	305	12	3470	123	5552	15375
EF8 / EFO8	2.4	8	2.59	8.5	1070	280	610	24	8780	310	14048	38750
EF10 / EFO10	3.0	10	3.25	10.7	1670	440	610	24	17790	628	28464	78500
EF12 / EFO12	3.6	12	3.89	12.8	2475	655	610	24	31220	1103	49952	137875

\*Increased sump depth may be added to increase sediment storage capacity

\*\* Average density of wet packed sediment in sump = 1.6 kg/L (100 lb/ft³ )

Feature	Benefit	Feature Appeals To
Patent-pending enhanced flow treatment and scour prevention technology	Superior, verified third-party performance	Regulator, Specifying & Design Engineer
Third-party verified light liquid capture and retention for EFO version	Proven performance for fuel/oil hotspot locations	Regulator, Specifying & Design Engineer, Site Owner
Functions as bend, junction or inlet structure	Design flexibility	Specifying & Design Engineer
Minimal drop between inlet and outlet	Site installation ease	Contractor
Large diameter outlet riser for inspection and maintenance	Easy maintenance access from grade	Maintenance Contractor & Site Owner

### STANDARD STORMCEPTOR EF/EFO DRAWINGS

For standard details, please visit <http://www.imbriumsystems.com/stormwater-treatment-solutions/stormceptor-ef>

### STANDARD STORMCEPTOR EF/EFO SPECIFICATION

For specifications, please visit <http://www.imbriumsystems.com/stormwater-treatment-solutions/stormceptor-ef>

Stormceptor® **EF** Sizing Report

**STANDARD PERFORMANCE SPECIFICATION FOR  
“OIL GRIT SEPARATOR” (OGS) STORMWATER QUALITY TREATMENT DEVICE**

**PART 1 – GENERAL**

1.1 WORK INCLUDED

This section specifies requirements for selecting, sizing, and designing an underground Oil Grit Separator (OGS) device for stormwater quality treatment, with third-party testing results and a Statement of Verification in accordance with ISO 14034 Environmental Management – Environmental Technology Verification (ETV).

1.2 REFERENCE STANDARDS & PROCEDURES

ISO 14034:2016 Environmental management – Environmental technology verification (ETV)

Canadian Environmental Technology Verification (ETV) Program’s **Procedure for Laboratory Testing of Oil-Grit Separators.**

1.3 SUBMITTALS

1.3.1 All submittals, including sizing reports & shop drawings, shall be submitted upon request with each order to the contractor then forwarded to the Engineer of Record for review and acceptance. Shop drawings shall detail all OGS components, elevations, and sequence of construction.

1.3.2 Alternative devices shall have features identical to or greater than the specified device, including: treatment chamber diameter, treatment chamber wet volume, sediment storage volume, and oil storage volume.

1.3.3 Unless directed otherwise by the Engineer of Record, OGS stormwater quality treatment product substitutions or alternatives submitted within ten days prior to project bid shall not be accepted. All alternatives or substitutions submitted shall be signed and sealed by a local registered Professional Engineer, based on the exact same criteria detailed in Section 3, in entirety, subject to review and approval by the Engineer of Record.

**PART 2 – PRODUCTS**

2.1 OGS POLLUTANT STORAGE

The OGS device shall include a sump for sediment storage, and a protected volume for the capture and storage of petroleum hydrocarbons and buoyant gross pollutants. The **minimum** sediment & petroleum hydrocarbon storage capacity shall be as follows:

2.1.1	4 ft (1219 mm) Diameter OGS Units:	1.19 m <sup>3</sup> sediment / 265 L oil
	6 ft (1829 mm) Diameter OGS Units:	3.48 m <sup>3</sup> sediment / 609 L oil
	8 ft (2438 mm) Diameter OGS Units:	8.78 m <sup>3</sup> sediment / 1,071 L oil
	10 ft (3048 mm) Diameter OGS Units:	17.78 m <sup>3</sup> sediment / 1,673 L oil
	12 ft (3657 mm) Diameter OGS Units:	31.23 m <sup>3</sup> sediment / 2,476 L oil

**PART 3 – PERFORMANCE & DESIGN**

3.1 GENERAL



## Stormceptor®EF Sizing Report

The OGS stormwater quality treatment device shall be verified in accordance with ISO 14034:2016 Environmental management – Environmental technology verification (ETV). The OGS stormwater quality treatment device shall remove oil, sediment and gross pollutants from stormwater runoff during frequent wet weather events, and retain these pollutants during less frequent high flow wet weather events below the insert within the OGS for later removal during maintenance. The Manufacturer shall have at least ten (10) years of local experience, history and success in engineering design, manufacturing and production and supply of OGS stormwater quality treatment device systems, acceptable to the Engineer of Record.

### 3.2 SIZING METHODOLOGY

The OGS device shall be engineered, designed and sized to provide stormwater quality treatment based on treating a minimum of 90 percent of the average annual runoff volume and a minimum removal of an annual average 60% of the sediment (TSS) load based on the Particle Size Distribution (PSD) specified in the sizing report for the specified device. Sizing of the OGS shall be determined by use of a minimum ten (10) years of local historical rainfall data provided by Environment Canada. Sizing shall also be determined by use of the sediment removal performance data derived from the ISO 14034 ETV third-party verified laboratory testing data from testing conducted in accordance with the Canadian ETV protocol Procedure for Laboratory Testing of Oil-Grit Separators, as follows:

3.2.1 Sediment removal efficiency for a given surface loading rate and its associated flow rate shall be based on sediment removal efficiency demonstrated at the seven (7) tested surface loading rates specified in the protocol, ranging 40 L/min/m<sup>2</sup> to 1400 L/min/m<sup>2</sup>, and as stated in the ISO 14034 ETV Verification Statement for the OGS device.

3.2.2 Sediment removal efficiency for surface loading rates between 40 L/min/m<sup>2</sup> and 1400 L/min/m<sup>2</sup> shall be based on linear interpolation of data between consecutive tested surface loading rates.

3.2.3 Sediment removal efficiency for surface loading rates less than the lowest tested surface loading rate of 40 L/min/m<sup>2</sup> shall be assumed to be identical to the sediment removal efficiency at 40 L/min/m<sup>2</sup>. No extrapolation shall be allowed that results in a sediment removal efficiency that is greater than that demonstrated at 40 L/min/m<sup>2</sup>.

3.2.4 Sediment removal efficiency for surface loading rates greater than the highest tested surface loading rate of 1400 L/min/m<sup>2</sup> shall assume zero sediment removal for the portion of flow that exceeds 1400 L/min/m<sup>2</sup>, and shall be calculated using a simple proportioning formula, with 1400 L/min/m<sup>2</sup> in the numerator and the higher surface loading rate in the denominator, and multiplying the resulting fraction times the sediment removal efficiency at 1400 L/min/m<sup>2</sup>.

The OGS device shall also have sufficient annual sediment storage capacity as specified and calculated in Section 2.1.

### 3.3 CANADIAN ETV or ISO 14034 ETV VERIFICATION OF SCOUR TESTING

The OGS device shall have Canadian ETV or ISO 14034 ETV Verification of third-party scour testing conducted in accordance with the Canadian ETV Program's **Procedure for Laboratory Testing of Oil-Grit Separators**.

3.3.1 To be acceptable for on-line installation, the OGS device must demonstrate an average scour test effluent concentration less than 10 mg/L at each surface loading rate tested, up to and including 2600 L/min/m<sup>2</sup>.

# StormTech<sup>®</sup> MC-3500 Chamber

Designed to meet the most stringent industry performance standards for superior structural integrity while providing designers with a cost-effective method to save valuable land and protect water resources. The StormTech system is designed primarily to be used under parking lots, thus maximizing land usage for private (commercial) and public applications. StormTech chambers can also be used in conjunction with Green Infrastructure, thus enhancing the performance and extending the service life of these practices.

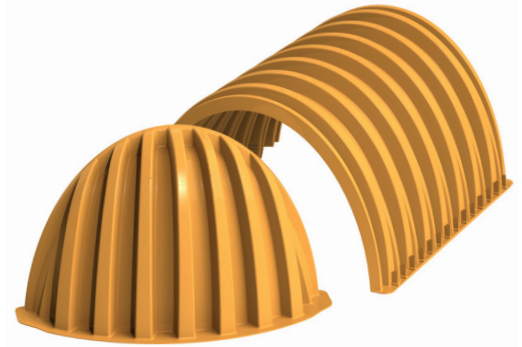

## Nominal Chamber Specifications (not to scale)

**Size (L x W x H)**  
 90" x 77" x 45"  
 2286 mm x 1956 mm x 1143 mm

**Chamber Storage**  
 109.9 ft<sup>3</sup> (3.11 m<sup>3</sup>)

**Min. Installed Storage\***  
 175.0 ft<sup>3</sup> (4.96 m<sup>3</sup>)

**Weight**  
 134 lbs (60.8 kg)

**Shipping**  
 15 chambers/pallet  
 7 end caps/pallet  
 7 pallets/truck

\*Assumes a minimum of 12" (300 mm) of stone above, 9" (230 mm) of stone below chambers, 6" (150 mm) of stone between chambers/ end caps and 40% stone porosity.

## Nominal End Cap Specifications (not to scale)

**Size (L x W x H)**  
 26.5" x 71" x 45.1"  
 673 mm x 1803 mm x 1145 mm

**End Cap Storage**  
 14.9 ft<sup>3</sup> (0.42 m<sup>3</sup>)

**Min. Installed Storage\***  
 45.1 ft<sup>3</sup> (1.28 m<sup>3</sup>)

**Weight**  
 49 lbs (22.2 kg)

\*Assumes a minimum of 12" (300 mm) of stone above, 9" (230 mm) of stone below, 6" (150 mm) of stone perimeter, 6" (150 mm) of stone between chambers/ end caps and 40% stone porosity.

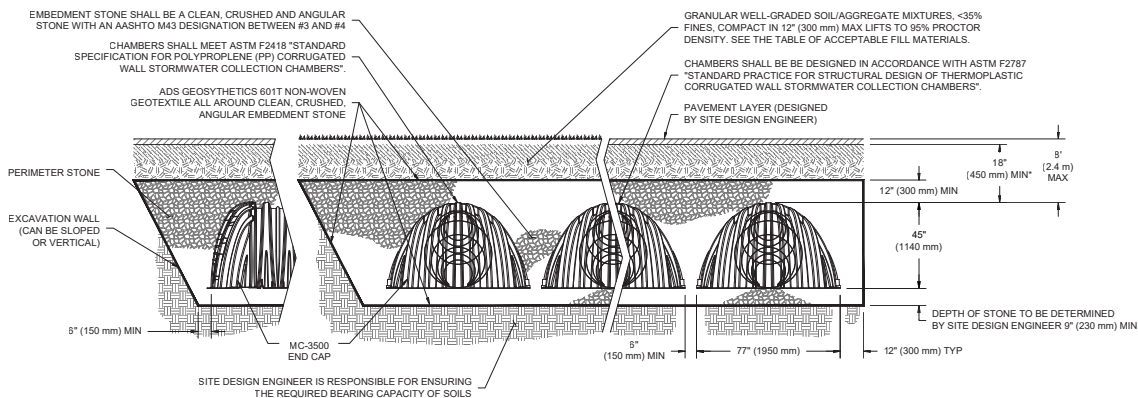
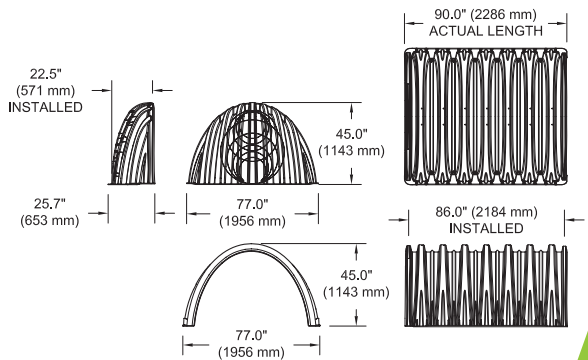

\*MINIMUM COVER TO BOTTOM OF FLEXIBLE PAVEMENT. FOR UNPAVED INSTALLATIONS WHERE RUTTING FROM VEHICLES MAY OCCUR, INCREASE COVER TO 24" (600 mm).

# StormTech MC-3500 Specifications

## Storage Volume Per Chamber

	Bare Chamber Storage ft <sup>3</sup> (m <sup>3</sup> )	Chamber and Stone Foundation Depth in. (mm)			
		9 in (230 mm)	12 in (300 mm)	15 in (375 mm)	18 in (450 mm)
Chamber	109.9 (3.11)	175.0 (4.96)	179.9 (5.09)	184.9 (5.24)	189.9 (5.38)
End Cap	14.9 (0.42)	45.1 (1.28)	46.6 (1.32)	48.3 (1.37)	49.9 (1.41)

**Note:** Assumes 6" (150 mm) row spacing, 40% stone porosity, 12" (300 mm) stone above and includes the bare chamber/end cap volume.

## Amount of Stone Per Chamber

English Tons (yds <sup>3</sup> )	Stone Foundation Depth			
	9 in	12 in	15 in	18 in
Chamber	8.5 (6.0)	9.1 (6.5)	9.7 (6.9)	10.4 (7.4)
End Cap	3.9 (2.8)	4.1 (2.9)	4.3 (3.1)	4.5 (3.2)
Metric Kilograms (m <sup>3</sup> )	230 mm	300 mm	375 mm	450 mm
Chamber	7711 (4.6)	8255 (5.0)	8800 (5.3)	9435 (5.7)
End Cap	3538 (2.1)	3719 (2.2)	3901 (2.4)	4082 (2.5)

**Note:** Assumes 12" (300 mm) of stone above and 6" (150 mm) row spacing and 6" (150 mm) of perimeter stone in front of end caps.

## Volume Excavation Per Chamber yd<sup>3</sup> (m<sup>3</sup>)

	Stone Foundation Depth			
	9 in (230 mm)	12 in (300 mm)	15 in (375mm)	18 in (450 mm)
Chamber	11.9 (9.1)	12.4 (9.5)	12.8 (9.8)	13.3 (10.2)
End Cap	4.0 (3.1)	4.1 (3.3)	4.3 (3.3)	4.4 (3.4)

**Note:** Assumes 6" (150 mm) of separation between chamber rows and 24" (600 mm) of cover. The volume of excavation will vary as depth of cover increases.

ADS StormTech products, manufactured in accordance with ASTM F2418 or ASTM F2922, comply with all requirements in the Build America, Buy America (BABA) Act.

**Working on a project?**

Visit us at [adspipe.com/stormtech](https://adspipe.com/stormtech) and utilize the Design Tool



[adspipe.com](https://adspipe.com)

800-821-6710

# MC-3500 TECHNICAL SPECIFICATION

NTS

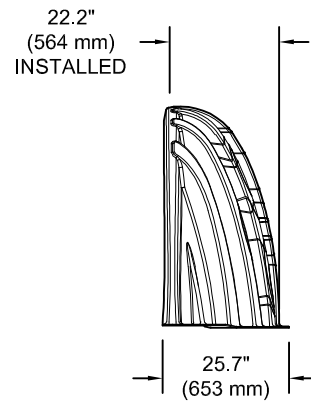
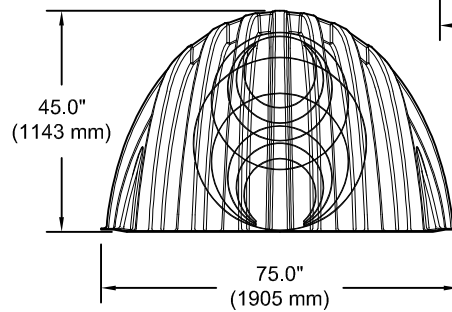
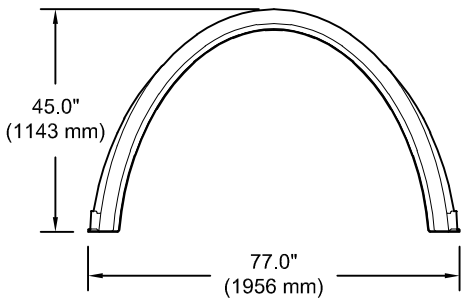
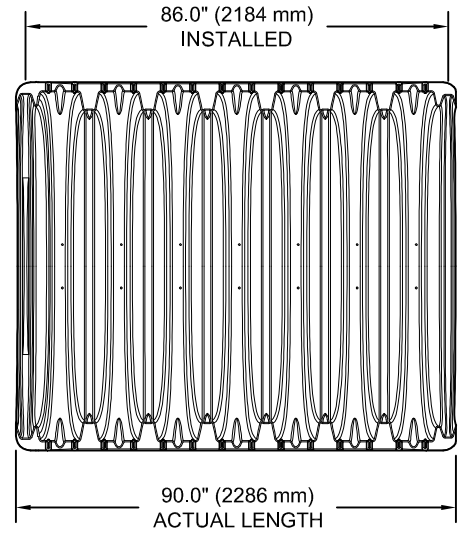
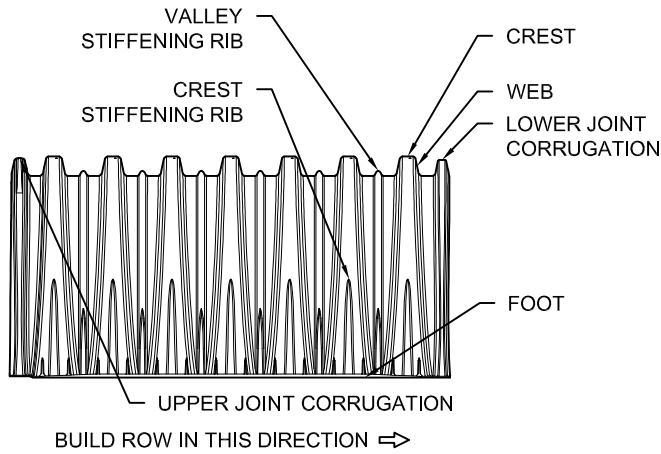

**NOMINAL CHAMBER SPECIFICATIONS**

SIZE (W X H X INSTALLED LENGTH)	77.0" X 45.0" X 86.0"	(1956 mm X 1143 mm X 2184 mm)
CHAMBER STORAGE	109.9 CUBIC FEET	(3.11 m <sup>3</sup> )
MINIMUM INSTALLED STORAGE* WEIGHT	175.0 CUBIC FEET	(4.96 m <sup>3</sup> )
	134 lbs.	(60.8 kg)

**NOMINAL END CAP SPECIFICATIONS**

SIZE (W X H X INSTALLED LENGTH)	75.0" X 45.0" X 22.2"	(1905 mm X 1143 mm X 564 mm)
END CAP STORAGE	14.9 CUBIC FEET	(0.42 m <sup>3</sup> )
MINIMUM INSTALLED STORAGE* WEIGHT	45.1 CUBIC FEET	(1.28 m <sup>3</sup> )
	49 lbs.	(22.2 kg)

\*ASSUMES 12" (305 mm) STONE ABOVE, 9" (229 mm) STONE FOUNDATION, 6" (152 mm) STONE BETWEEN CHAMBERS, 6" (152 mm) STONE PERIMETER IN FRONT OF END CAPS AND 40% STONE POROSITY.

PARTIAL CUT HOLES AT BOTTOM OF END CAP FOR PART NUMBERS ENDING WITH "B"  
 PARTIAL CUT HOLES AT TOP OF END CAP FOR PART NUMBERS ENDING WITH "T"  
 END CAPS WITH A PREFABRICATED WELDED STUB END WITH "W"  
 END CAPS WITH A WELDED CROWN PLATE END WITH "C"

PART #	STUB	B	C
MC3500IEPP06T	6" (150 mm)	33.21" (844 mm)	---
MC3500IEPP06B		---	0.66" (17 mm)
MC3500IEPP08T	8" (200 mm)	31.16" (791 mm)	---
MC3500IEPP08B		---	0.81" (21 mm)
MC3500IEPP10T	10" (250 mm)	29.04" (738 mm)	---
MC3500IEPP10B		---	0.93" (24 mm)
MC3500IEPP12T	12" (300 mm)	26.36" (670 mm)	---
MC3500IEPP12B		---	1.35" (34 mm)
MC3500IEPP15T	15" (375 mm)	23.39" (594 mm)	---
MC3500IEPP15B		---	1.50" (38 mm)
MC3500IEPP18TC	18" (450 mm)	20.03" (509 mm)	---
MC3500IEPP18TW			---
MC3500IEPP18BC		---	1.77" (45 mm)
MC3500IEPP18BW		---	---
MC3500IEPP24TC	24" (600 mm)	14.48" (368 mm)	---
MC3500IEPP24TW			---
MC3500IEPP24BC		---	2.06" (52 mm)
MC3500IEPP24BW		---	---
MC3500IEPP30BC	30" (750 mm)	---	2.75" (70 mm)

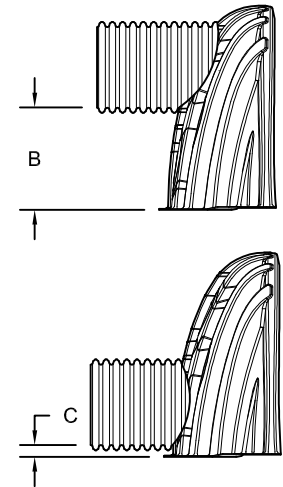

CUSTOM PARTIAL CUT INVERTS ARE AVAILABLE UPON REQUEST. INVENTORIED MANIFOLDS INCLUDE 12-24" (300-600 mm) SIZE ON SIZE AND 15-48" (375-1200 mm) ECCENTRIC MANIFOLDS. CUSTOM INVERT LOCATIONS ON THE MC-3500 END CAP CUT IN THE FIELD ARE NOT RECOMMENDED FOR PIPE SIZES GREATER THAN 10" (250 mm). THE INVERT LOCATION IN COLUMN 'B' ARE THE HIGHEST POSSIBLE FOR THE PIPE SIZE.

NOTE: ALL DIMENSIONS ARE NOMINAL

**AMENDMENT NO. 247  
TO THE  
SAULT STE. MARIE OFFICIAL PLAN**

**PURPOSE**

This Amendment is an amendment to the Text of the Official Plan as it relates to the Housing and Commercial Policies, and to the Land Use Map (Schedule C).

**LOCATION**

PT SEC 32 TARENTORUS; PT LT 18 RCP H732 TARENTOROUS PTS 2, 3, 4, 6 & 7, 1R-13874; S/T T232886; SAULT STE. MARIE; PT SEC 32 TARENTOUS; PT LT 18 RCP H732 TARENTOROUS PT 1, 1R-13874; S/T T342880; SAULT STE. MARIE, having Civic Number 352/360 Northern Avenue and 31 Old Garden River Road, located at the northeast corner of the Northern Avenue East and Great Northern Rd.

**BASIS**

The Text Amendments are necessary in view of an application to permit:

- a. New commercial development up 750m<sup>2</sup> on residential lands
- b. Permit major office space outside of the Downtown Area

Council now considers it desirable to amend the Official Plan.

**DETAILS OF THE ACTUAL AMENDMENT & POLICIES RELATED THERETO**

The Official Plan for the City of Sault Ste. Marie is hereby amended by adding the following paragraph to the Special Exceptions Section:

162. Notwithstanding Residential Policy R.7 and Commercial Policy C.4 of the Official Plan, the property described PT SEC 32 TARENTORUS; PT LT 18 RCP H732 TARENTOROUS PTS 2, 3, 4, 6 & 7, 1R-13874; S/T T232886; SAULT STE. MARIE; PT SEC 32 TARENTOUS; PT LT 18 RCP H732 TARENTOROUS PT 1, 1R-13874; S/T T342880; SAULT STE. MARIE, having Civic Number 352/360 Northern Avenue and 31 Old Garden River Road, located at the northeast corner of the Northern Avenue East and Great Northern Rd., may allow commercial including major office space upon the subject area development up to 750m<sup>2</sup> and be located outside the Downtown Area.

**INTERPRETATION**

The provisions of the Official Plan as amended from time to time will be applied to this Amendment.



## Salvatore Marchese

---

**From:** Diane Morrell  
**Sent:** Friday, June 2, 2023 2:12 PM  
**To:** Salvatore Marchese  
**Subject:** RE: 352/360 Northern Ave and 31 Old Garden River Rd.

Hi Sal,

Sorry for the late reply.

The only comment on the A-3-23-Z.OP 360 Northern Avenue (CARA Community Corp.) application is regarding safe crossing of Great Northern Road for persons with disabilities. This was brought forward to me (and others) via Councillor Caputo on behalf of residents in this area. I have no suggested solutions for this.

The Site Plan Sub-Committee looks forward to seeing the Site Plan application.

Thanks,

Diane Morrell

---

**From:** Salvatore Marchese <s.marchese@cityssm.on.ca>  
**Sent:** Thursday, June 1, 2023 5:10 PM  
**To:** Diane Morrell <d.morrell@cityssm.on.ca>  
**Subject:** 352/360 Northern Ave and 31 Old Garden River Rd.

Hello Diane,

I am writing my report regarding the proposal for 352/360 Northern Ave. and 31 Old Garden Rive Rd. Stephanie circulated materials to you a couple weeks ago, but I don't have any comments from you. I wanted to see if you had anything before I submit my report.

Regards,

**Salvatore Marchese**

Junior Planner

Planning and Enterprise Services

[s.marchese@cityssm.on.ca](mailto:s.marchese@cityssm.on.ca)

705-759-5445

**CITY OF SAULT STE. MARIE**

99 Foster Drive, Sault Ste. Marie, ON P6A 5X6

[saultstemarie.ca](http://saultstemarie.ca)



## Salvatore Marchese

---

**From:** Francois Couture  
**Sent:** Wednesday, May 24, 2023 9:12 AM  
**To:** Stephanie Perri  
**Subject:** RE: Request for Comment - Rezoning Applications A-2-23-Z.OP and A-3-23-Z.OP

**Follow Up Flag:** Follow up  
**Flag Status:** Flagged

Hello Stephanie,

Building has not objections or comments for the 1692 Peoples Road application, we wish to advise the applicant of 360 Northern Avenue that consideration must be taken to the requirements of the Limiting Distances and area of Unprotected Openings of 3.2.3.1.OBC. and overhead power lines when the building is constructed closer to the property lines.

Sincerely,

Francois.

---

**From:** Stephanie Perri <s.perri@cityssm.on.ca>  
**Sent:** Wednesday, May 17, 2023 10:30 AM  
**To:** Carl Rumiel <c.rumiel@cityssm.on.ca>; Dan Perri <d.perri@cityssm.on.ca>; Maggie McAuley <m.mcauley@cityssm.on.ca>; Freddie Pozzebon <f.pozzebon@cityssm.on.ca>; Francois Couture <f.couture@cityssm.on.ca>; Karen Fields <k.fields@cityssm.on.ca>; Tom Vair <t.vair@cityssm.on.ca>; Naomi Thibault <n.thibault@cityssm.on.ca>; Rick Van Staveren <r.vanstaveren@cityssm.on.ca>; eng dept <eng-dept@ssmpuc.com>; Virginia McLeod <v.mcleod@cityssm.on.ca>; Diane Morrell <d.morrell@cityssm.on.ca>; Susan Hamilton Beach <s.hamiltonbeach@cityssm.on.ca>; SSMRCA <nature@ssmrca.ca>; MSONorth@ontario.ca; 'circulations@wsp.com' <circulations@wsp.com>; 'planninganddevelopment@bell.ca' <planninganddevelopment@bell.ca>; newdevelopment@rci.rogers.com; THERIAULT, Raynald <raynald.theriault@canadapost.postescanada.ca>; 'EH Clerical' <ehclerical@algomapublichealth.com>  
**Cc:** Orsalina Naccarato <o.naccarato@cityssm.on.ca>; Amanda Cipriano <a.cipriano@cityssm.on.ca>  
**Subject:** Request for Comment - Rezoning Applications A-2-23-Z.OP and A-3-23-Z.OP

Good morning

Below is a link to the following rezoning applications for your review/comment:

- A-2-23-Z.OP 1692 Peoples Road (Luke Barban) - Planner: Nick Cicchini; and
- A-3-23-Z.OP 360 Northern Avenue (CARA Community Corp.) - Planner: Salvatore Marchese

[https://cityssmcanada-my.sharepoint.com/:f/g/personal/s\\_perri\\_cityssm\\_on\\_ca/EuPs-qMV\\_OJNpFzrMa-15XYB9ErdWSwbRK3F-VMlxAh0HA?e=hTbs18](https://cityssmcanada-my.sharepoint.com/:f/g/personal/s_perri_cityssm_on_ca/EuPs-qMV_OJNpFzrMa-15XYB9ErdWSwbRK3F-VMlxAh0HA?e=hTbs18)

Your comments would be appreciated on or before **May 31, 2023**.

Please advise if you require anything further or if you have trouble accessing the link.

Thank you for your assistance.

Stephanie

Stephanie Perri

Administrative Clerk  
Planning and Enterprise Services  
[s.perri@cityssm.on.ca](mailto:s.perri@cityssm.on.ca)  
705-574-1022

**CITY OF SAULT STE. MARIE**  
99 Foster Drive, Sault Ste. Marie, ON P6A 5X6  
[saultstemarie.ca](http://saultstemarie.ca)



## Salvatore Marchese

---

**From:** THERIAULT, Raynald <raynald.theriault@canadapost.postescanada.ca>  
**Sent:** Wednesday, May 17, 2023 10:38 AM  
**To:** Stephanie Perri  
**Subject:** RE: Request for Comment - Rezoning Applications A-2-23-Z.OP and A-3-23-Z.OP

This email originated outside of the Corporation of the City of Sault Ste. Marie.  
Do not open attachments or click links unless you verify the sender and know the content is safe.

Hi Stephanie,  
As this is only a rezoning application, Canada Post will not comment on this.  
If the rezoning is approved and a plan is put forth, then Canada Post will need to comment at that time.  
Let me know if you have any questions/concerns.

Ray Theriault  
Delivery Services Officer  
613-793-2293  
Raynald.theriault@canadapost.ca

---

**From:** Stephanie Perri <s.perri@cityssm.on.ca>  
**Sent:** May-17-23 10:30 AM  
**To:** Carl Rumiell <c.rumiell@cityssm.on.ca>; Dan Perri <d.perri@cityssm.on.ca>; Maggie McAuley <m.mcauley@cityssm.on.ca>; Freddie Pozzebon <f.pozzebon@cityssm.on.ca>; Francois Couture <f.couture@cityssm.on.ca>; Karen Fields <k.fields@cityssm.on.ca>; Tom Vair <t.vair@cityssm.on.ca>; Naomi Thibault <n.thibault@cityssm.on.ca>; Rick Van Staveren <r.vanstaveren@cityssm.on.ca>; eng dept <eng-dept@ssmpuc.com>; Virginia McLeod <v.mcleod@cityssm.on.ca>; Diane Morrell <d.morrell@cityssm.on.ca>; Susan Hamilton Beach <s.hamiltonbeach@cityssm.on.ca>; SSMRCA <nature@ssmrca.ca>; MSNorth@ontario.ca; 'circulations@wsp.com' <circulations@wsp.com>; 'planninganddevelopment@bell.ca' <planninganddevelopment@bell.ca>; newdevelopment@rci.rogers.com; THERIAULT, Raynald <raynald.theriault@canadapost.postescanada.ca>; 'EH Clerical' <ehclerical@algomapublichealth.com>  
**Cc:** Orsalina Naccarato <o.naccarato@cityssm.on.ca>; Amanda Cipriano <a.cipriano@cityssm.on.ca>  
**Subject:** Request for Comment - Rezoning Applications A-2-23-Z.OP and A-3-23-Z.OP

This email is from an EXTERNAL sender. Please be CAUTIOUS, particularly with links and attachments. | Ce courriel est d'un expéditeur EXTERNE. Soyez PRUDENT, en particulier avec des liens et des pièces jointes.

Good morning

Below is a link to the following rezoning applications for your review/comment:

- A-2-23-Z.OP 1692 Peoples Road (Luke Barban) - Planner: Nick Cicchini; and
- A-3-23-Z.OP 360 Northern Avenue (CARA Community Corp.) - Planner: Salvatore Marchese

[https://cityssmcanada-my.sharepoint.com/:f/g/personal/s\\_perri\\_cityssm\\_on\\_ca/EuPs-qMV\\_OJNpFzrMa-15XYB9ErdWSwbRK3F-VMlxAh0HA?e=hTbs18](https://cityssmcanada-my.sharepoint.com/:f/g/personal/s_perri_cityssm_on_ca/EuPs-qMV_OJNpFzrMa-15XYB9ErdWSwbRK3F-VMlxAh0HA?e=hTbs18)

Your comments would be appreciated on or before **May 31, 2023**.

Please advise if you require anything further or if you have trouble accessing the link.

Thank you for your assistance.

Stephanie

**Stephanie Perri**

Administrative Clerk

Planning and Enterprise Services

[s.perri@cityssm.on.ca](mailto:s.perri@cityssm.on.ca)

705-574-1022

**CITY OF SAULT STE. MARIE**

99 Foster Drive, Sault Ste. Marie, ON P6A 5X6

[saultstemarie.ca](http://saultstemarie.ca)



Individuals who submit written correspondence or information to the City should be aware that any personal information contained in their communications may become part of the public record and made available to the public through the Council Agenda process or that of a committee of Council or a local board.

May 31, 2023

Peter Tonazzo  
Director of Planning  
The Corporation of the  
City of Sault Ste. Marie  
99 Foster Drive  
Sault Ste. Marie, ON P6A 5X6

Email: [s.perri@cityssm.on.ca](mailto:s.perri@cityssm.on.ca)

Dear Peter:

Re: Northern Ave E [360/352] and Old Garden River Rd [31] – Application No. #A-3-23-Z.OP

With regards to the above referenced rezoning application, please refer to the below comments:

PUC Distribution Inc. (Electric Utility)

- No concerns with the proposed rezoning.
- Please provide an electrical site servicing plan showing proposed services, existing services, and property boundaries.
- Any existing easements and infrastructure are to remain or be re-evaluated when a detailed site plan is provided.
- It is recommended that the owner contact PUC well in advance of finalizing their design to discuss electrical servicing requirements of the proposed development.

Public Utilities Commission of the City of Sault Ste. Marie (Water Utility)

- No concerns with the proposed rezoning.
- Please provide a water site servicing plan showing proposed services, existing services, and property boundaries.
- Any existing easements and infrastructure are to remain or be re-evaluated when a detailed site plan is provided.

- It is recommended that the owner contact PUC well in advance of finalizing their design to discuss water servicing requirements of any proposed development.

We would also like to take the opportunity to request that the developer reach out to us early in the planning stages with respect to electrical servicing for the development.

Yours truly,  
PUC Services Inc.

A handwritten signature in black ink that reads "M Paradis".

Mitchell Paradis, P.Eng.  
Manager, Electrical Engineering

MP\*km

## Salvatore Marchese

---

**From:** Dan Perri  
**Sent:** Wednesday, May 31, 2023 3:00 PM  
**To:** Salvatore Marchese  
**Subject:** RE: Updated Servicing Report CARA

Salvatore,

I won't have any additional comments from the original circulation. I will get you the formal response ASAP, but so I don't delay your report, do not expect any comments in the response.

Thanks,  
Dan

---

**From:** Salvatore Marchese <s.marchese@cityssm.on.ca>  
**Sent:** Wednesday, May 31, 2023 1:45 PM  
**To:** Dan Perri <d.perri@cityssm.on.ca>  
**Subject:** Updated Servicing Report CARA

Hello Dan,

Here is the updated servicing report for the CARA developments on 352/360 Great Northern. I am going to be writing the report tomorrow night, if there are any preliminary comments before then please shoot them my way.

Regards,

**Salvatore Marchese**  
Junior Planner  
Planning and Enterprise Services  
[s.marchese@cityssm.on.ca](mailto:s.marchese@cityssm.on.ca)  
705-759-5445

**CITY OF SAULT STE. MARIE**  
99 Foster Drive, Sault Ste. Marie, ON P6A 5X6  
[saultstemarie.ca](http://saultstemarie.ca)







2020 12 17

**MEMO TO:** Don McConnell, RPP  
Planning Director

**RE:** A-17-20-Z  
352-360 Northern Avenue  
Cara Community Corporation

The Engineering Division has reviewed the above noted application and provides the following:

- Stormwater management may be required.
- A 3m road widening is required along Northern Avenue.
- A lot grading and drainage plan must be completed by a Lot Grading Professional, to ensure that drainage is dealt with appropriately. Lot Grading Professionals must be a Professional Engineer (civil), Architect, or Ontario Land Surveyor, experienced in lot grading design.
- It is understood that this property is subject to Site Plan Control. The proposed plan will reviewed during site plan approval to ensure servicing and drainage is addressed to the satisfaction of the Director of Engineering or his designate.

If you have any questions, please do not hesitate to contact the undersigned.

A handwritten signature in black ink, appearing to read 'M. McAuley', is written over a light blue horizontal line.

Maggie McAuley, P. Eng.  
Municipal Services Engineer  
Public Works & Engineering Services  
705.759.5385  
[m.mcauley@cityssm.on.ca](mailto:m.mcauley@cityssm.on.ca)

MM

cc. Susan Hamilton Beach, Public Works  
Don Elliott, Engineering

**SUBJECT PROPERTIES**

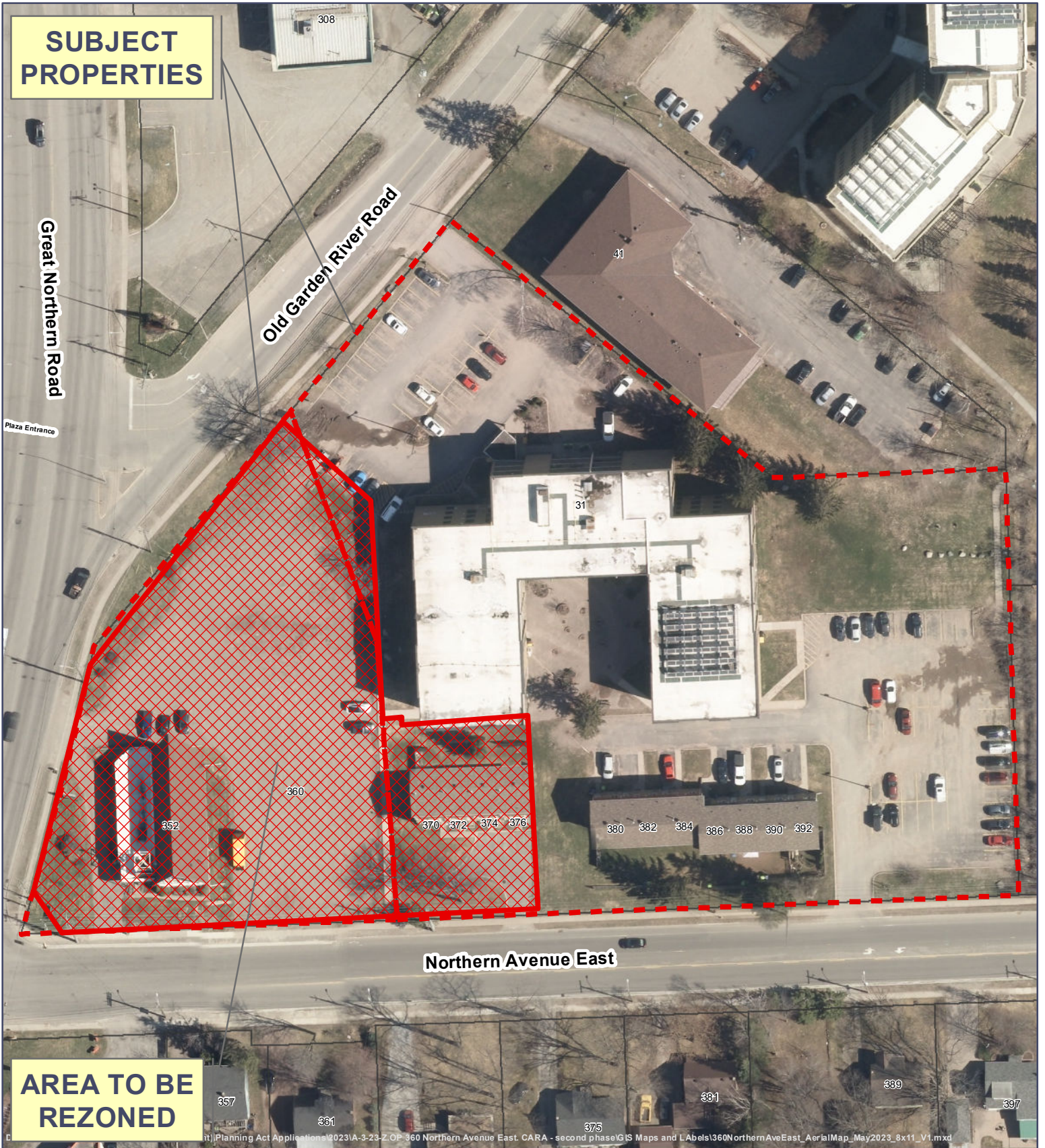

**AREA TO BE REZONED**

it\Planning Act Applications\2023\A-3-23-Z.OP 360 Northern Avenue East. CARA - second phase\GIS Maps and Labels\360NorthernAveEast\_AerialMap\_May2023\_8x11\_V1.mxd

**Application Map Series**  
 Subject Property  Official Plan Landuse  
 Existing Zoning  Aerial Image  
 Official Plan Amendment

**Legal Department Reference**



**SAULT STE. MARIE**  
**Planning and Enterprise Services**  
 Community Development and Enterprise Services Department  
 99 Foster Drive, Sault Ste Marie, ON P6A 5X6  
 saultstemarie.ca | 705-759-5368 | planning@cityssm.on.ca

*This map is for general reference only*  
 Orthophoto: 2022  
 Projection Details:  
 NAD 1983 UTM Zone 16N  
 GCS North American 1983



**Property Information**  
 Civic Address: 352/360 Northern Avenue East,  
 31 Old Garden River Road  
 Roll No.: 030081001000000, 030081002000000  
 Map No.: 71/1-76  
 Application No.: A-3-23-Z.OP  
 Date Created: May 15, 2023

**Legend**

-  Area to be Rezoned
-  Subject Properties:  
352/360 Northern Avenue East,  
31 Old Garden River Road
-  Public Fabric

Page 306 of 529

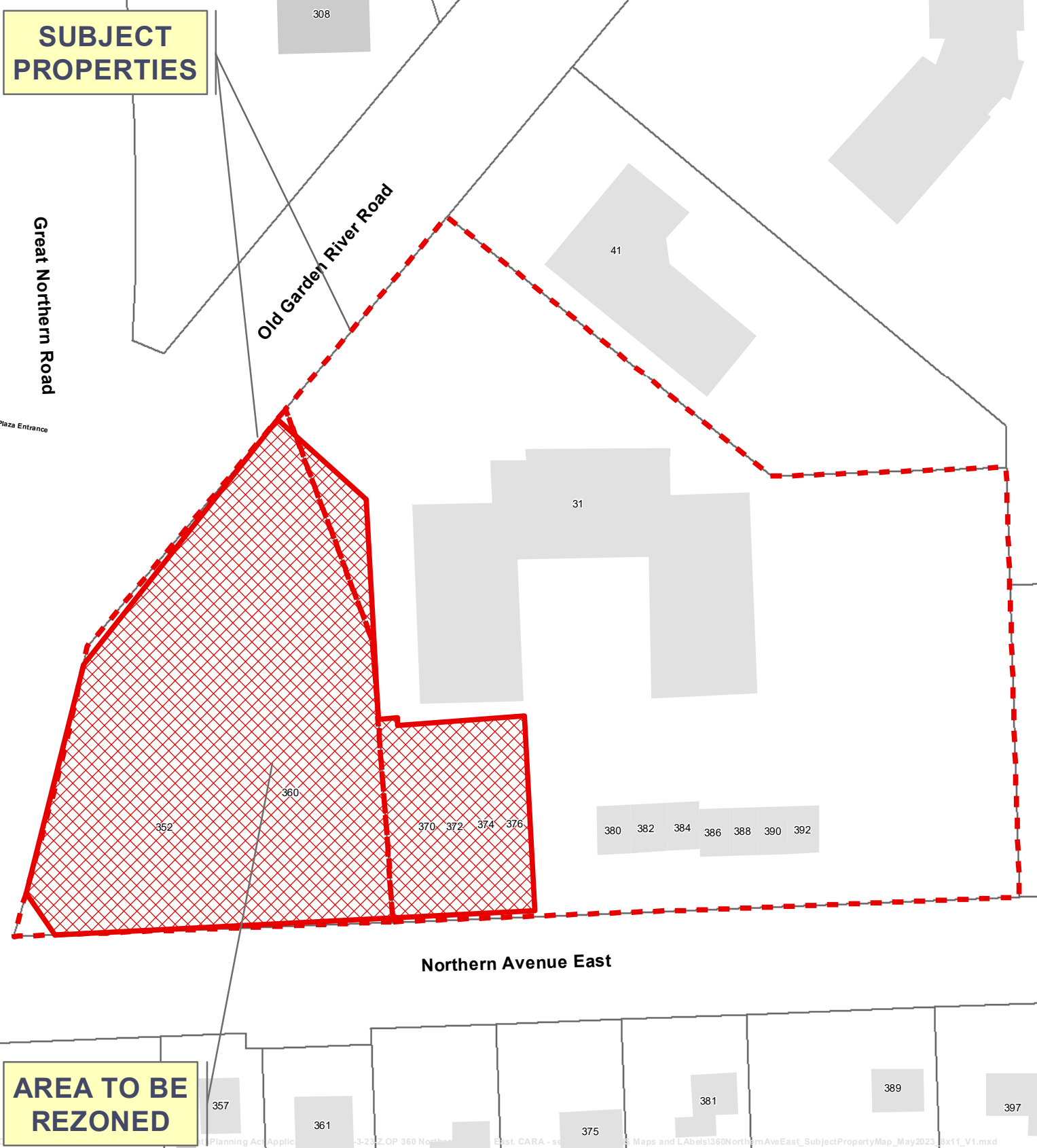

**SUBJECT PROPERTIES**

**AREA TO BE REZONED**

**Application Map Series**  
 Subject Property  Official Plan Landuse  
 Existing Zoning  Aerial Image  
 Official Plan Amendment

**Legal Department Reference**





**SAULT STE. MARIE**  
**Planning and Enterprise Services**  
 Community Development and Enterprise Services Department  
 99 Foster Drive, Sault Ste Marie, ON P6A 5X6  
[saultstемarie.ca](http://saultstемarie.ca) | 705-759-5368 | [planning@cityssm.on.ca](mailto:planning@cityssm.on.ca)  
*This map is for general reference only*  
 Orthophoto: None  
 Projection Details:  
 NAD 1983 UTM Zone 16N  
 GCS North American 1983



**Property Information**  
 Civic Address: 352/360 Northern Avenue East,  
 31 Old Garden River Road  
 Roll No.: 030081001000000, 030081002000000  
 Map No.: 71/1-76  
 Application No.: A-3-23-Z.OP  
 Date Created: May 15, 2023

**Legend**

-  Area to be Rezoned
-  Subject Properties:  
352/360 Northern Avenue East,  
31 Old Garden River Road
-  Parcel Fabric

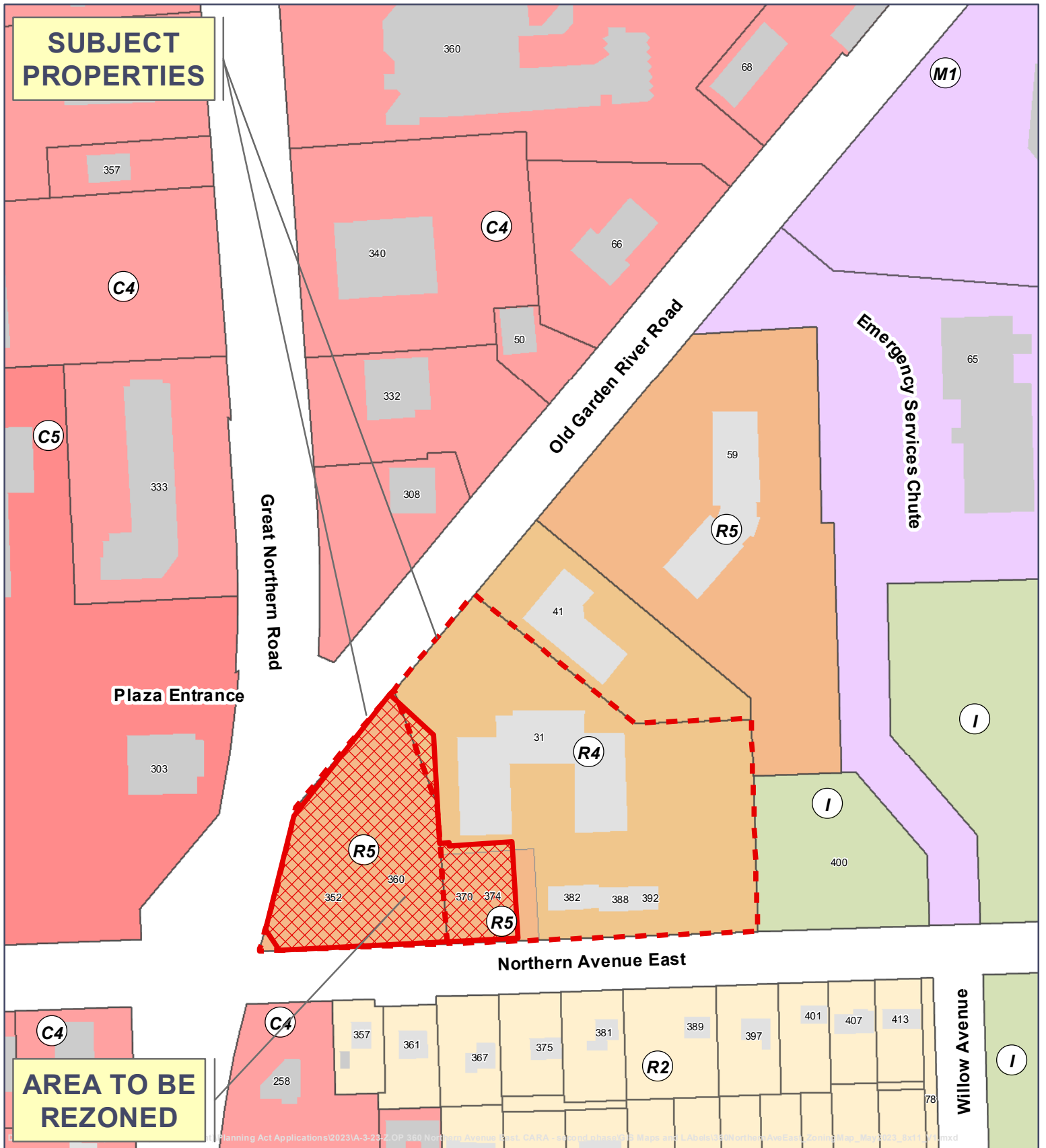

**SUBJECT PROPERTIES**

**AREA TO BE REZONED**

- Application Map Series**
- Subject Property
  - Official Plan Landuse
  - Existing Zoning
  - Aerial Image
  - Official Plan Amendment

**Property Information**  
 Civic Address: 352/360 Northern Avenue East,  
 31 Old Garden River Road  
 Roll No.: 030081001000000, 030081002000000  
 Map No.: 71/1-76  
 Application No.: A-3-23-Z.OP  
 Date Created: May 15, 2023

**Legend**

- C1 - Traditional Commercial Zone
- C2 - Central Commercial Zone
- CT2 - Commercial Transitional Zone
- C3 - Riverfront Zone; C3hp
- C4 - General Commercial Zone; C4hp
- C5 - Shopping Centre Zone
- H2 - Highway Zone
- M1 - Light Industrial Zone
- M2 - Medium Industrial Zone; M2hp
- M3 - Heavy Industrial Zone
- R1 - Estate Residential Zone
- R2 - Single Detached Residential Zone; R2hp
- R3 - Low Density Residential Zone
- R4 - Medium Density Residential Zone
- R5 - High Density Residential Zone
- R6 - Mobile Home Residential Zone
- I - Institutional Zone
- EM - Environmental Management Zone
- PR - Parks and Recreation Zone
- RA - Rural Area Zone
- RP - Rural Precambrian Uplands Zone
- REX - Rural Aggregate Extraction Zone
- AIR - Airport Zone
- Named Use - Commercial Dock
- Parcel
- Subject Properties
- Area to be Rezoned

**SAULT STE. MARIE**  
 Planning and Enterprise Services  
 Community Development and Enterprise Services Department  
 99 Foster Drive, Sault Ste Marie, ON P6A 5X6  
 saultstемarie.ca | 705-759-5368 | planning@cityssm.on.ca

*This map is for general reference only*  
 Orthophoto: None  
 Projection Details:  
 NAD 1983 UTM Zone 16N  
 GCS North American 1983

0 10 20 40 Meters  
 1:2,000

Page 308 of 529



The Corporation of the City of Sault Ste. Marie  
 99 Foster Drive, Sault Ste. Marie, Ontario P6A 5X6  
 saultstemarie.ca | 705.759.2500 | info@cityssm.on.ca

## NOTICE OF APPLICATION & PUBLIC MEETING

### 352/360 NORTHERN AVENUE EAST & 31 OLD GARDEN RIVER ROAD

Application No.: A-3-23-Z.OP

Applicant: CARA Community Corporation

Date: Monday, June 19, 2023  
 Time: 5:30 PM

Location: City of Sault Ste. Marie  
 Civic Centre, Council Chambers  
 99 Foster Drive

#### PURPOSE

The applicant, CARA Community Corporation, has submitted an application for site specific Official Plan and Rezoning amendments. The effect of these amendments would facilitate the construction of a nine storey building providing 108 residential units, 750 m<sup>2</sup> of commercial space, and a chapel on the subject area. The commercial and chapel space will be located on the ground floor. The application also proposes to reduce the required side yard setbacks, reduce the number of required parking spaces, permit parking spaces in a required side yard setback, and slightly reduce the required amount of landscaped open space

#### PROPOSED CHANGE

Amend the Official Plan's residential land use policies by way of a notwithstanding clause to Policy R.7 to permit commercial development of up to 750 m<sup>2</sup> on the subject area, whereas R.7 of the OP only permits 200m<sup>2</sup>, and Amend the Official Plan's commercial Land use policies by way of a notwithstanding clause to Policy C.4 to permit major office space outside of the defined Downtown Area.

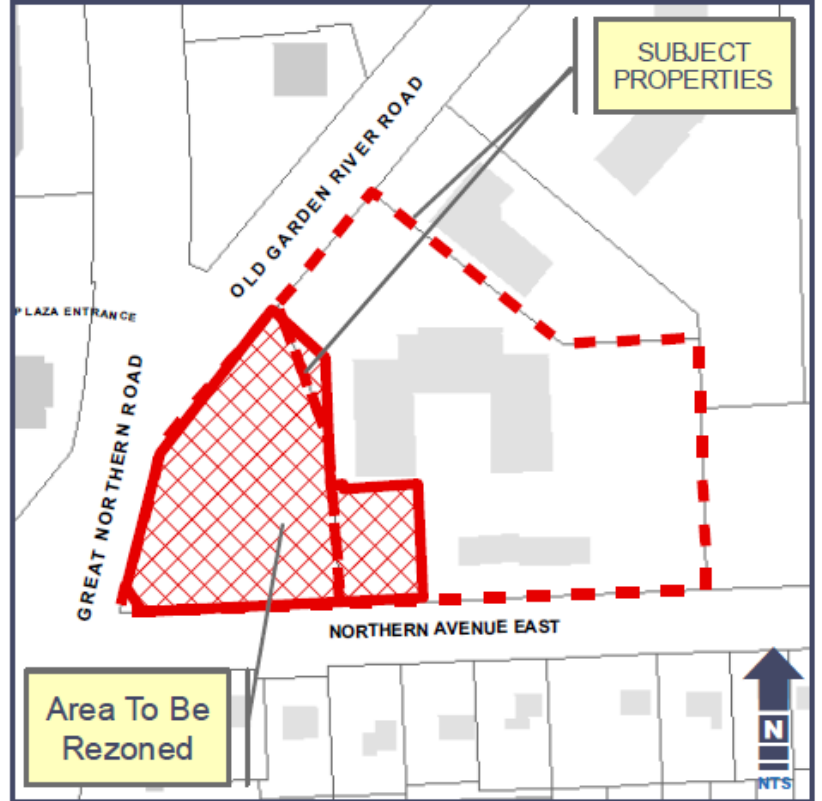

Rezone the subject area from High Density Residential Zone (R5.S-405) With Special Exception 405 to High Density Residential Zone (R5.S) with a new Special Exception to permit, in addition to the uses already permitted in an R5 zone, up to 750 m<sup>2</sup> of commercial space, subject to the following provisions:

1. Permitted commercial uses include office uses, food services, personal services, retail trade, amusement and fitness facilities, arts culture and heritage uses, bingo halls, and similar; and they are all to be subject to the same regulations as the proposed apartment building.
2. Reduce the required east interior side yard setback to 0 meters to accommodate an enclosed corridor between the proposed building and the existing building on the abutting property.
3. Reduce the combined number of required parking spaces from 185 to 101 spaces for the proposed 108 unit apartment, the existing 4-unit multiple-attached dwellings, the place of worship, and the commercial use of the property.
4. That a minimum of 9 barrier-free parking spaces be provided.
5. Reduce the west exterior side yard Setback from 13.5 to 4 meters.
6. Permit parking within the required front (south) and exterior (west) side yards.
7. Waive the need to provide a dedicated loading space as required by Section 6 of the Zoning By-law.
8. Reduce the required landscaped open space from 33% to 29%.

**TAKE NOTICE THAT** the Council of The Corporation of the City of Sault Ste. Marie will hold a Public Meeting on Monday, June 19, 2023 at 5:30 p.m. to consider an Official Plan Amendment and Zoning By-law Amendment (under sections 17, 22 and 34 of the Planning Act, R.S.O 1990, c. P13, as amended). This meeting will be broadcast by Shaw Cable and may be viewed on Shaw Cable's Community Channel, Sootoday.com and on the City's YouTube Channel <https://www.youtube.com/saultstemarieca>

Any person wishing to present at the public meeting may do so electronically or in person. Electronic participants must contact the City Clerk at [cityclerk@cityssm.on.ca](mailto:cityclerk@cityssm.on.ca) or 705-759-5388 to register as a presenter. Registered presenters will be provided with instructions as to how to join the meeting in advance Any written submissions received in advance of the meeting will be included with Council's Agenda.

**MORE INFORMATION**

The application may be reviewed upon request. The report of the Planning Division will be available on Friday, June 16, 2023 as part of City Council's Agenda. Please contact Salvatore Marchese 705.759.5445 or [s.marchese@cityssm.on.ca](mailto:s.marchese@cityssm.on.ca) to request a digital copy. Please refer to the application file number.

**WRITTEN SUBMISSION**

To provide input in writing, or request notice if the proposed application is approved, please submit a letter to Salvatore Marchese, 99 Foster Drive, Sault Ste. Marie, ON P6A 5X6, or e-mail to [s.marchese@cityssm.on.ca](mailto:s.marchese@cityssm.on.ca) with your name, address and application file number on or before **Monday, June 19, 2023**.

If you wish to be notified of the Council of the City of Sault Ste. Marie decision to adopt or refuse the approval of an application, you must make a written request to the Planning Division at the address noted above.

**LEGAL NOTICE CONCERNING YOUR RIGHT TO APPEAL**

If a person or public body does not make oral submission at a public meeting or make written submission to the City of Sault Ste. Marie before the By-law is passed, the person or public body may not be entitled to appeal the decision of the Council of the City of Sault Ste. Marie to the Ontario Land Tribunal.

If a person or public body does not make oral submissions at a public meeting, or make written submissions to the City of Sault Ste. Marie before the By-law is passed, the person or public body may not be added as a party to the hearing of an appeal before the Ontario Land Tribunal unless, in the opinion of the Tribunal, there are reasonable grounds to add the person or public body as a party.

**SITE PLAN REQUIREMENTS:**

**AREAS:**

- TOTAL SITE AREA = 45024 sq-ft
- EXISTING 4 UNIT TOWNHOUSE BLDG = 1024 sq-ft
- PROPOSED 104 UNIT / 6 STOREY APARTMENT BUILDING (FOOTPRINT) = 10150 sq-ft (NOT INCLUDING PARKING)
- TOTAL BUILDING AREA = 11174 sq-ft
- LOT COVERAGE PROPOSED = 24.8%
- MAX. ALLOWABLE LOT COVERAGE = 33%
- LANDSCAPED AREA = 12210 sq-ft (100% TOP OVER HAMP)
- MIN. ALLOWABLE LANDSCAPING = 3315 sq-ft
- LANDSCAPING AREA PROPOSED = 30.4% (MINIMUM SERVICE 10% D)

**PARKING - REQUIREMENTS:**

- EXISTING TOWNHOUSE (4 UNITS AT 1 SPACE / UNIT) = 4 SPACES
- PROPOSED 104 UNIT APARTMENT AT 1.25 SPACES / UNIT = 130 SPACES
- TOTAL SPACES REQUIRED = 134 SPACES

**PARKING PROVIDED:**

- ABOVE GROUND PARKING = 53 SPACES
- BELOW GROUND PARKING (MINOR) = 80 SPACES
- TOTAL SPACES PROVIDED = 133 SPACES (MINOR VARIANCE 10% D)

**SETBACKS REQUIRED:**

- NORTH = 13.5m (1/2 BLDG #1)
- SOUTH = 13.5m (1/2 BLDG #1)
- EAST = 13.5m (1/2 BLDG #1)
- WEST = 13.5m (1/2 BLDG #1)

**SETBACKS PROVIDED:**

- NORTH = 24.6m (1) (MINOR VARIANCE 1) = 74.1%
- SOUTH = 16.0m (1) (MINOR VARIANCE 2) = 51.9%
- EAST = 7.2m (1) (MINOR VARIANCE 2) = 21.5%
- WEST = 4.2m (1) (MINOR VARIANCE 2) = 12.6%

**EXISTING ZONING:**

- R2 - HIGH DENSITY RESIDENTIAL ZONE

**PROPOSED ZONING:**

- R2 - HIGH DENSITY RESIDENTIAL ZONE

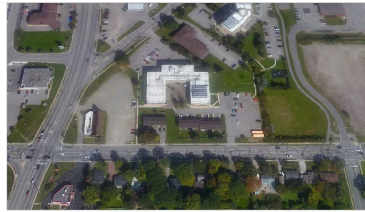

**mgp**  
 crd@acts - engineer inc.  
 122 East Street  
 Sault Ste. Marie, ON  
 P6A 5C7  
 705.942.9494  
 www.mgparcheng.ca

**NOTES:**  
 1. THIS DRAWING IS THE PROPERTY OF MGP ARCHITECTURE & ENGINEERING INC. AND IS TO BE USED ONLY FOR THE PROJECT AND SITE SPECIFICALLY IDENTIFIED HEREIN. ANY REUSE OR MODIFICATION OF THIS DRAWING WITHOUT THE WRITTEN PERMISSION OF MGP ARCHITECTURE & ENGINEERING INC. IS STRICTLY PROHIBITED. THE USER OF THIS DRAWING SHALL BE RESPONSIBLE FOR OBTAINING ALL NECESSARY PERMITS AND APPROVALS FROM THE APPROPRIATE AUTHORITIES.

DATE: 04/20/23  
 DRAWN BY: [Name]  
 CHECKED BY: [Name]  
 ISSUED FOR REVIEW

**PRELIMINARY DRAWINGS  
 NOT FOR CONSTRUCTION**

**PROJECT:**  
 TRINITY TOWERS  
 9-STOREY APARTMENT  
 CARA COMMUNITY CORPORATION

**LOCATION:**  
 104 UNIT APARTMENT BUILDING  
 104 UNIT APARTMENT BUILDING  
 104 UNIT APARTMENT BUILDING

**DATE:**  
 05/11/23

**SCALE:**  
 N.T.S.

**DATE:**  
 05/11/23

**SCALE:**  
 N.T.S.

**PROJECT NUMBER:**  
 2023-001

**DRAWING NUMBER:**  
 A1.0

**THE CORPORATION OF THE CITY OF SAULT STE. MARIE**

**BY-LAW 2023-94**

**AGREEMENT**: A by-law to authorize the execution of the Agreement between the City and Mill Market Sault Ste. Marie for a lease agreement for the Mill Market.

**THE COUNCIL** of The Corporation of the City of Sault Ste. Marie, pursuant to section 9 of the *Municipal Act, 2001*, S.O. 2001, c. 25, **ENACTS** as follows:

1. **EXECUTION OF DOCUMENT**

The Mayor and City Clerk are hereby authorized for and in the name of the Corporation to execute and affix the seal of the Corporation to the Agreement dated June 19, 2023 between the City and Mill Market Sault Ste. Marie, a copy of which is attached as Schedule "A" hereto. This Agreement is for a lease agreement for the Mill Market.

2. **SCHEDULE "A"**

Schedule "A" forms part of this by-law.

3. **EFFECTIVE DATE**

This by-law takes effect on the day of its final passing.

**PASSED** in open Council this 19<sup>th</sup> day of June, 2023.

---

**MAYOR – MATTHEW SHOEMAKER**

---

**CITY CLERK – RACHEL TYCZINSKI**

# Schedule "A"

## LEASE AGREEMENT

This Lease is made effective the 19<sup>th</sup> day of June, 2023 in pursuance of the *Short Forms of Leases Act* ("Lease").

### BETWEEN:

**THE CORPORATION OF THE CITY  
OF SAULT STE. MARIE**

(herein referred to as the "City")

– and –

**MILL MARKET SAULT STE. MARIE**

(herein referred to as the "Mill Market")

**WHEREAS** the City and Mill Market entered into an original Lease Agreement dated July 15, 2019 (the "Original Lease Agreement") to lease the lands owned by the City known as 35 Canal Drive, Sault Ste. Marie, Ontario, and legally described as PT HUDSON'S BAY COMPANY'S LANDS S/S PORTAGE ST PL TOWN PLOT OF SAULT STE. MARIE PT 10-12 1R5809, PT 2, 3 1R5709, PT 6-10 1R9799; S/T T257669E, for the purpose of a Farmer's Market/Public Market and related ancillary uses and parking for same;

**AND WHEREAS** the Original Lease Agreement had a Term of five (5) years, commencing July 15, 2019 and terminating July 30, 2024 (the "Original Lease Term"), with the option to renew the Original Lease Agreement for up to two (2) additional five (5) year terms upon the same terms and conditions, save for this right of renewal;

**AND WHEREAS** the Original Lease Agreement was amended by By-law 2020-130 passed on July 13, 2020, whereby pursuant to Section 2(l), additional terms and conditions in response to the COVID-19 pandemic were added to same;

**AND WHEREAS** the Original Lease Agreement was further amended by a Second Amending Lease Agreement dated April 11, 2022, approved by Council By-law 2022-059, which resulted in the placement of two (2) mobile food retail units owned by the City at 35 Canal Drive, Sault Ste. Marie, Ontario, and the lease of same to Mill Market pursuant to Section 14 of the Original Lease Agreement to be occupied by successful proponents to a Request for Proposal initiated by Mill Market and on the terms and conditions set out in the Second Amending Lease Agreement;

**AND WHEREAS** the City and Mill Market further entered into a Licence to Occupy City Property Agreement dated April 11, 2022, approved by Council By-law 2022-060 which leased to Mill Market, and further permitted Mill Market to occupy and operate one light duty food and retail unit owned by the City at the location identified at Schedule "A" to the Licence to Occupy City Property, being South of Ken Danby Way which the parties hereto acknowledge and agree did not thereafter materialize;

**WHEREAS** the City is the owner of the lands in the City of Sault Ste. Marie municipally known as 73 Brock Street, Sault Ste. Marie, Ontario and legally described as

PIN 31542-0389 (LT), BEING FIRSTLY: LOTS 6-8 PLAN 138 ST. MARY'S; S 1/2 LOT 5 PLAN 138 ST. MARY'S; SECONDLY: 2 FOOT RESERVE PLAN 138 ST. MARY'S; 2 FOOT RESERVE PLAN 366MCD ST. MARY'S; PART LANE PLAN 138 ST. MARY'S; PART LANE PLAN 366MCDST. MARY'S PART 1,4,5 & 8 1R9480 CLOSED BY T388549; PART LOT 11 PLAN 366MCD ST. MARY'S PART 1 PLAN 1R9277; S/T & T/W T404811; S/T T240452, T240561, T392044, T393283; CITY OF SAULT STE. MARIE

outlined on Schedule "A" attached herein and described as the "Premises";



**AND WHEREAS** Mill Market desires to relocate the Farmer's Market/Public Market from 35 Canal Drive to the Premises once the Premises is ready for occupation and the City is agreeable to same, subject to the terms and conditions set out herein;

**AND WHEREAS** Mill Market, a not for profit corporation, is desirous of housing and operating a Farmers' Public Market along with the associated parking on the Premises for the benefit of the citizens of Sault Ste. Marie and surrounding district;

**AND WHEREAS** Mill Market further desires to lease four (4) mobile retail units owned by the City to be placed at the City Property comprising the Downtown Plaza, legally described as:

FIRSTLY: LT 4-10, PL 366MCD ST. MARY'S; PT LT 11 PL 366MCD ST. MARYS PT 2 1R9277; LT 15 PL 366MCD ST. MARY'S; LT 16PL 366MCD ST. MARY'S AS IN T47998; LT 17 PL 366MCD ST. MARY'S; LOTS 18-20 PLAN 366 EXCEPT PARTS 3 & 4, 1R13935 PTLT 10 N/S BAY ST PL TOWN PLOT OF ST. MARY'S AS IN T143982; PT LT 1 PL 138 ST. MARY'S AS IN T392376; LOTS 6-8 PLAN 138ST. MARY'S S 1/2 LOT 5 PLAN 138 ST. MARY'S; PT MCDUGALD ST PL 366MCD ST. MARY'S AS IN T219159 CLOSED BY T219159; SUBJECT TO AN EASEMENT OVER PART OF MCDUGALD ST PLAN 366, PART 5, 1R13935 AS IN AL249076;MCDUGALD ST PL 366MCD ST. MARYS N OF T219159 (AKA BINGHAM ST) CLOSED BY BY-LAW 2022-108 AS IN AL254068; 15FT LANE PL 366MCD ST. MARYS N OF LT 4 6, CLOSED BY BY-LAW 2022-108 AS IN AL254068; 15 FT LANE PL 366MCD ST.MARYS N OF LT 15 17, CLOSED BY BY-LAW 2022-108 AS IN AL254068; 2 FT RESERVE PL 366 MCD ST. MARYS S OF LT 6,CLOSED BY BY-LAW 2022-108 AS IN AL254068; 2 FT RESERVE PL 366MCD ST. MARYS N OF LT 17, CLOSED BY BY-LAW 2022-108 AS IN AL254068; CITY OF SAULT STE. MARIESECONDLY: 2 FOOT RESERVE PLAN 138 ST. MARY'S; 2 FOOT RESERVE PLAN366MCD ST. MARY'S; PART LANE PLAN 138 ST.MARY'S; PART LANE PLAN 366MCD ST. MARY'S PART 1,4,5 & 8 1R9480 CLOSED BY T388549; PART LOT 11 PLAN 366MCD ST.MARY'S PART 1 PLAN 1R9277; S/T & T/W T404811; S/T T240452,T240561, T392044, T393283; CITY OF SAULT STE. MARIE.

and at the locations shown in red on Schedule "B" attached hereto (the "Mobile Unit City Property"), and the City is also agreeable to same, subject to the terms and conditions set out herein;

**AND WHEREAS** the Mill Market was successful in obtaining the Rural Economic Development Program Grant in the amount of Two Hundred Fifty Thousand (\$250,000.00) Dollars as evidenced by Agreement between then Her Majesty The Queen in Right of Ontario and Mill Market Sault Ste. Marie, a copy of which is appended as Schedule "C" this Lease (hereinafter the "RED Grant");

**AND WHEREAS** the Mill Market was successful in obtaining federal funding from the Green and Inclusive Community Buildings Grant up to a maximum federal funding of \$1,711,596.00 as evidenced by an Approval Letter in Principle dated December 7, 2022 a copy of which is appended as Schedule "D" to this Lease (hereinafter the "GICB Grant"), which:

- (a) sets out a number of conditions that Mill Market must meet;
- (b) which Mill Market represents it has satisfied some of the conditions and shall undertake to satisfy the remaining conditions on the terms and conditions as set out in this Lease; and
- (c) which Mill Market advises its agreement with Infrastructure Canada ("INFC") has yet to be finalized and executed between the Mill Market and INFC;

**AND WHEREAS** the Mill Market acknowledges that it has requested the City to undertake the tendering process required under the terms and conditions of both the GICB Grant and the RED Grant on its behalf for the construction and renovation/leasehold improvement costs at the Premises to create the necessary space for the Mill Market and the City has done same including completion of the tendering process, awarding and entering into a contract for the construction and renovation costs/leasehold improvements, and further has incurred and paid the expenses associated with the construction and renovation/leasehold improvements of the Premises (the "Project");

**AND WHEREAS** Mill Market represents that it has submitted and shall continue to submit some of the expenses incurred by the City thereunder for the Project as "eligible expenses" under the RED Grant for reimbursement and has and undertakes to continue to forward any such reimbursement received under the RED Grant to the City, and further the City acknowledges having been reimbursed by Mill Market some of the Project expenses;

**AND WHEREAS** Mill Market represents and warrants to the City that INFC has provided the required advance approval that it will accept the City's procurement process for the Project as satisfying this condition for the GICB Grant funding to satisfy the condition that:

*Mill Market Sault Ste. Marie will establish and use competitive and transparent tendering process unless approved in advance by INFC;*

and further that INFC has confirmed the claims that will be submitted by Mill Market under the GICB Grant will include the costs associated with the Project;

**AND WHEREAS** Mill Market undertakes to submit to INFC regarding the GICB Grant, the costs incurred by the City for the Project for reimbursement as "Eligible Expenses" immediately upon the City submitting same to Mill Market and further undertakes to forthwith forward any such reimbursement received under the GICB Grant to the City,

**NOW THEREFORE** in consideration of the sum of One (\$1.00 CDN) Dollar, the receipt of which is hereby acknowledged by the City and the mutual covenants, agreements and promises hereinafter set forth, the parties for themselves and their respective permitted assigns do hereby covenant and agree with one another as follows:

**LEASE OF PREMISES – 73 BROCK STREET**

1. The City hereby leases the Premises, including existing ancillary parking at the Premises to the Mill Market for a period of Twenty-Five (25) Years, commencing July 1, 2023 (the "Commencement Date") and terminating on June 30, 2048 (collectively the "Term"). The Commencement Date may be changed on the written agreement of the Parties to an earlier date if the Premises is ready for occupancy. In the event that the Premises is not ready for occupancy on July 1, 2023, the determination of which shall be made by the City, based on the status of the construction taking place at the Premises, the parties hereto acknowledge and agree to adjust the Commencement Date accordingly to a date that the Premises is ready for occupancy. The City delegates the authority to make that determination and adjust the new Commencement Date to the Deputy CAO, Community Development and Enterprise Services. The City shall not be responsible for any costs, liabilities or expenses incurred by Mill Market as a result of any adjustment of the Commencement Date.

**RENT, RED GRANT AND GICB GRANT**

2. The parties hereto acknowledge and agree that Rent shall be One (\$1.00) per year during the initial Term if the following conditions are satisfied by Mill Market:
  - (a) Mill Market has and continues to submit some of the expenses incurred by the City for the Project as "Eligible Expenses" under the RED Grant for reimbursement. To this end, Mill Market represents and warrants that:
    - a. Any and all expenses that Mill Market has submitted to RED are "Eligible Expenses" under the RED Grant;
    - b. Mill Market has complied with and shall continue to comply with all the Terms and Conditions of the RED Grant Agreement appended as Schedule "C" to this Lease. Further, Mill Market shall be solely responsible for all matters as set out in the RED Grant Agreement;
    - c. Mill Market has and undertakes to immediately continue to forward any and all reimbursement and funds received by Mill Market from the RED Grant up to the amount of \$250,000.00 to the City; and
    - d. Mill Market shall forthwith provide the City with any documentation of any nature and kind that is requested by the City as it relates to the RED Grant; and
  - (b) Mill Market acknowledges and agrees that the Approval Letter in Principle appended as Schedule "D" to this Lease sets out numerous conditions, including but not limited to the following:
    - a. That Mill Market Sault Ste. Marie will establish and use a competitive and transparent tendering processes unless approved in advance by Infrastructure Canada;

- b. That the Project must be authorized or endorsed by a resolution of Council, Band or Board of Directors, as applicable and must be received before a funding agreement can be executed;
- c. That Mill Market complete any environmental assessments that may be required by the Ministry and/or GICB;
- d. That a funding agreement must be signed before any costs will be reimbursed, even if incurred; and
- e. That there could be further conditions.

To this end, Mill Market represents to the City that it has satisfied the conditions set out in the Approval Letter in Principle dated December 7, 2022, being Schedule "D" to this Lease, or undertakes to satisfy same on the following basis:

- a. Regarding Conditions a., c. and d. above:
  - i. Mill Market represents to the City and has represented to INFC that Mill Market shall be the recipient of the GICB Grant funds and shall enter into an Agreement with INFC and therefore be solely responsible for all matters as set out in the Approval Letter in Principle and the eventual Agreement with INFC;
  - ii. Mill Market has advised INFC that Mill Market requested the City to undertake the tendering process required under the terms and conditions of the GICB Grant and Approval Letter in Principle for the Project at the Premises and INFC has provided the required advance approval that it will accept the City's procurement process for the Project as satisfying this condition for the GICB Grant funding to satisfy the condition that:
    - Mill Market Sault Ste. Marie will establish and use competitive and transparent tendering process unless approved in advance by INFC;*
  - iii. Mill Market represents and warrants that it has reviewed the criteria for the GICB Grant and anticipates that the costs incurred by the City for the Project are "Eligible Expenses" under the GICB Grant criteria. Further, Mill Market has addressed received correspondence from INFC confirming that it will accept the costs incurred by the City for the Project as "Eligible Expenses" under the GICB Grant;
  - iv. Mill Market undertakes to submit to GICB the costs incurred by the City for the Project to INFC for reimbursement as "Eligible Expenses" immediately upon the City submitting same to Mill Market and further undertakes to forthwith forward any such reimbursement received under the GICB Grant to the City up to the amount of \$1,711,596.00. To this end, Mill Market has given notice to INFC that Mill Market shall be forwarding the GICB Grant monies it receives to the City; and
  - v. Mill Market undertakes to enter into an Agreement with INFC and be responsible for all other conditions and matters as will be set out in the Agreement;
- b. Regarding Condition b., Mill Market represents and warrants that its Board of Directors has passed a Resolution authorizing all matters as set out herein;
- c. Regarding Condition c. and e., Mill Market undertakes to take full responsibility and forthwith complete at its sole liability and expense any other conditions that may be imposed by INFC as it relates to the GICB Grant; and
- d. Mill Market shall forthwith provide the City with any documentation of any nature and kind that is requested by the City as it relates to the GICB Grant; and

(c) In no event shall the City be required to reimburse Mill Market for any monies the City has received from Mill Market pursuant to the RED Grant or GICB Grant.

- 3. In the event that the RED Grant and GICB Grant are terminated fully by the respective Ministries and/or there is a request by RED and GICB to return fully the RED Grant and GICB Grant monies paid, the parties acknowledge and agree as follows:

- (a) Mill Market shall pay the total sum of Four Hundred and Ten Thousand (\$410,000.00) Dollars total to the City for the Lease of the Premises, payable in equal monthly payments on a prorated basis over the Term, representing the total sum payable divided by the number of months in the Term remaining, which the parties agree such monthly payment shall be calculated by the City's Chief Financial Officer and Treasurer and be payable immediately thereafter by Mill Market on a monthly basis for the remainder of the Term; and
  - (b) The City shall be responsible to pay the respective Ministry the RED Grant and/or GICB Grant funds so requested if same is made in accordance with the terms and conditions of the RED Grant Agreement and the eventual GICB Grant Agreement. The City shall also be responsible for the Project costs at the Premises that were not reimbursed.
4. The parties acknowledge and agree that the total maximum funds payable by both the RED Grant of Two Hundred Fifty (\$250,000.00) Thousand Dollars and the GICB Grant of One Million Seven Hundred and Eleven Thousand, Five Hundred and Ninety-Two (\$1,711,592.00) Dollars is One Million Nine Hundred and Sixty One Thousand, Five Hundred and Ninety-Two (\$1,961,592.00) Dollars (hereinafter the "Total Grant Funds"). To that end, if a partial payment of the Total Grant Funds is made to Mill Market and then received by the City for any reason (hereinafter the "Partial Grant Funds"), including but not limited to either of the grants being partially or not payable, or a request for reimbursement of RED Grant and/or GICB Grant monies is made by the respective Ministries or a reassessment or penalty is assessed by the respective Ministries, the parties acknowledge and agree as follows:
- (a) The City shall retain in full the Partial Grant Funds paid to the City by Mill Market pursuant to the RED Grant and GICB Grant submissions;
  - (b) The City shall be responsible to pay the respective Ministry the RED Grant and/or GICB Grant funds so requested if same is made in accordance with the terms and conditions of the RED Grant Agreement and the eventual GICB Grant Agreement;
  - (c) If the total Partial Grant Funds received by the City is less than Four Hundred and Ten Thousand (\$410,000.00) Dollars, then:
    - a. Mill Market shall pay to the City as rent the amount representing the difference between the total Partial Grant Funds received by the City and the sum of Four Hundred and Ten Thousand (\$410,000.00) Dollars; and
    - b. The amount payable by Mill Market to the City as set out in Section 4(c)a. above shall be paid in equal monthly payments on a prorated basis over the Term, which the parties agree such monthly payment shall be calculated by the City's Chief Financial Officer and Treasurer and be payable immediately thereafter by Mill Market on a monthly basis for the remainder of the Term.
  - (d) If the total Partial Grant Funds received by the City is greater than Four Hundred and Ten Thousand (\$410,000.00) Dollars, then Mill Market shall be required to pay rent in the sum of \$1.00 per year for the balance of the Term;
  - (e) The City shall be responsible for the Project costs at the Premises that were not reimbursed.
5. Regardless of Sections 2-4 inclusive herein, Mill Market shall pay the City, the sum of Forty Thousand (\$40,000.00) Dollars plus applicable taxes on or before the Commencement Date, representing Mill Market's contribution to the leasehold improvements at the Premises. The parties acknowledge and agree that Mill Market has already paid the sum of Forty Thousand (\$40,000.00) Dollars as required herein to the City. This amount of Forty Thousand (\$40,000.00) Dollars is addition to any other rent payable pursuant to Sections 2-4 herein.

**RENEWAL TERM**

- 6. Provided it is not in material default under the terms of this Lease, or terminated pursuant to any Clauses set out in this Lease, Mill Market shall have the right upon written notice to the City to renew the Term as it relates to the Lease of the Premises for up to two (2) additional 5-year terms upon the same terms and conditions, save for this right of renewal.

**USE OF PREMISES AND MILL MARKET'S OBLIGATIONS**

7. Mill Market shall have quiet enjoyment of the Premises and exclusive use thereof except as otherwise expressly agreed. Provided however, the City shall have the right, upon reasonable notice and without interfering with Mill Market's operations, to inspect the Premises from time to time to ensure compliance hereto and to perform any required repairs.
8. The Premises shall be used only for the operation of a Farmer's Market/Public Market and related ancillary uses and parking for same. The parties acknowledge and agree that either party may request the use of the Premises for community events which shall not interfere with the use of the Premises as a Farmer's Market/Public Market and the other party shall not unreasonably withhold consent to such requests. To that end, the parties acknowledge and agree that the person having delegated authority to make the request and approve such requests shall be as follows:
  - (a) On behalf of the City, the Deputy CAO Community Development and Enterprise Services; and
  - (b) On behalf of Mill Market, the Market Manager.Such requests must be made in advance of the community event and are subject to the terms and conditions as set out in Appendix 1 to this Lease.
9. Mill Market shall be responsible and liable for all taxes, permits, licences, approvals or assessments of every nature and kind whatsoever, in any way arising from the presence and operation of the Market and shall be responsible to ensure that all vendors obtain the necessary approvals and permits relative to their business. Mill Market shall also be responsible to and liable to ensure any vendors selling alcohol have and maintain proper permits and licences, and have received AGCO approval for same prior to selling any alcohol at the Premises. At no time shall the City be responsible for any matters related to vending, permits, AGCO Licences and permits, public health requirements or approvals relating to the Farmer's Market/Public Market and related ancillary uses. Mill Market shall save harmless and fully indemnify the City from and against all losses, costs (including solicitor costs on a substantial indemnity scale basis and disbursements), damages and expenses of every kind or nature which the City may suffer, be at or be put to by reason of or in consequence of the noncompliance by the Mill Market regarding such taxes, permits, licences, approvals and assessments.
10. Mill Market shall ensure that there is no alcohol served or consumed at the Premises, interior or exterior at any time during the Term unless all necessary AGCO licences, permits and requirements have been secured and adhered to, and the Premises is designated by the City as a facility where alcohol use and consumption is permitted in the City's Alcohol Risk Management Policy. Thereafter, Mill Market shall ensure that any serving and consumption of alcohol at the Premises complies in all respects with the City's Alcohol Risk Management Policy.
11. Mill Market shall not do or permit to be done at the Premises anything which may:
  - a. Cause damage to the Premises or create a nuisance;
  - a. Make void or voidable any insurance upon the Premises; or
  - b. Constitute a breach of any by-law, statute, order or regulation of any municipal, provincial or other competent authority relating to the Premises.
12. This Lease shall not be assigned by Mill Market without the prior written approval of the City. The Mill Market expressly acknowledges responsibility for any such licensee(s).
13. Mill Market shall have the right to sublet a portion of the interior of the Premises to its members or third parties for purposes consistent with Mill Market's mission and operations as a Farmer's Market/Public Market upon the prior written approval of the City. For clarity, the subleases referred to herein are those that are outside of the vendor space area at the Premises, which shall require modification of the Interior of the Premises and are not the actual booths occupied by vendors as part of the Farmer's Market/Public Market. These sublease requests shall be considered by the Council of the City. Requests to sublet a portion of the interior of the Premises will not be unreasonably withheld by the City but shall be subject to terms and conditions that are deemed necessary by the City to

protect the City's interests. The Mill Market expressly acknowledges responsibility for any such sublessee(s).

14. The City shall be responsible, for the repair and replacement of all items which are not the responsibility of Mill Market, which include strictly the structural elements of the Premises, being the foundations, bearing walls, exterior finishes, heating, ventilating and air conditioning systems serving the Premises and the roof, including the roof membrane and structural elements of the roof, except to the extent that any such repairs or replacements are caused by the negligent or willful acts or omissions of Mill Market. The City shall further be responsible for snow removal of the parking lot at the Premises. The City shall further make the North Lot of 99 Foster Drive available for Mill Market patrons during Mill Market business hours and shall amend the signage to reflect same.
15. Mill Market shall be responsible at its sole expense to maintain the Premises in a good state of repair including, but not limited to landscaping, signage, garbage disposal, cleaning, snowplowing of the Entrances to the Premises, sanding, all necessary non-structural repairs to the Premises, including repairs to the interior exposed plumbing and exposed portions of the electrical systems, the maintenance and replacement of all equipment use in connection with the operation of the Mill Market, and those repairs required as a result of Mill Market's negligence except that Mill Market shall not be obligated to make any of the foregoing arising out of or in any way connected with (a) fire or other casualty, (b) settling, or (c) the negligence of the City or those for which it is in law responsible. For further clarity, the Mill Market shall not be responsible for the matters as set out in Section 14 herein.
16. Mill Market shall be responsible for payment of all utilities and services for the Premises, including but not limited to electricity, water, gas, sewer and those as set out in Clause 12 hereabove.
17. The City may enter and view the state of repair or cleanliness of the Premises during normal business hours and the Lessee will promptly repair, maintain and clean according to notice in writing from the City.
18. In the event that Mill Market fails to repair, maintain or clean in accordance with the provisions hereof, the City may enter the Premises and make the required repairs or do the required maintenance or cleaning and recover as rent herein from Mill Market the reasonable cost thereof and, provided the City and its agents act reasonably, the City will not be liable to Mill Market for any inconvenience, interruption, loss of business or any damage suffered by Mill Market by reason of the City effecting such repairs, maintenance or cleaning. For further clarify, the City shall not inspect/enter the Premises during the business hours of the Mill Market unless it is inspecting a matter that requires immediate and/or urgent attention. Further, the City shall have first provided Mill Market with reasonable time to effect the repairs, the time period of which shall be set out by the City in a notice from the City to the Mill Market before the City enters the Premises and completes the repairs, unless the repairs are required forthwith to ensure the integrity, structure and/or stability of the Premises or to address a safety issue.
19. Upon vacating the Premises at the end or earlier termination of the lease Term, unless otherwise agreed by the parties Mill Market will leave the Premises in the state of repair and cleanliness required to be maintained during the term of this Lease, reasonable wear and tear excepted and upon reasonable time to complete same. Further, the parties have entered into a Loan Agreement dated March 20, 2023 regarding the construction of vendor booths, a copy of which is appended as Appendix 2 hereto, and specifically, Section 10 and Sections 13-16 inclusive of the Loan Agreement are relevant to the rights and responsibilities of the City and Mill Market at the end of earlier termination of the lease Term as it relates to the vendor booths. The parties hereto acknowledge and agree that Section 10 and Section 13-16 inclusive of the Loan Agreement are incorporated herein and set out the rights and responsibilities of the parties hereto as it relates to the Vendor Booths at the end or earlier termination of the lease Term.

20. The parties acknowledge that the City will apply to have the Premises designated a Municipal Capital Facility. Should such designation be deemed not to apply to the Mill Market by MPAC, the City shall be responsible for the payment of any taxes that may be assessed against the Premises during the Term of this Lease and may provide to the Mill Market an offsetting grant to cover the difference in the assessment by MPAC if not deemed a Municipal Capital Facility. In the event that the designation of Municipal Capital Facility is deemed not to apply to the Mill Market by MPAC as a result of any sublease by Mill Market or other licence by Mill Market, then the Mill Market shall be responsible for the payment of any taxes that may be assessed against the Premises during the Term of this Lease.
21. Mill Market agrees to maintain at all times during the currency of this licence hereinbefore described the following insurance for the Premises:
- (a) a minimum of Five Million (\$5,000,000.00) Dollars comprehensive general liability insurance in respect of personal injury, death, loss or damage of or to any person or property of third parties, with insurers licenced to conduct business in Ontario. The City shall be added as an Additional Insured to the required liability insurance policy or policies and no such policy shall be cancelled or allowed to lapse without at least thirty (30) days written notice having been given to the City. An Insurance Certificate, on the C.S.I.O. form and satisfactory to the City's Risk Manager, shall be provided to the City prior to the commencement of the Licence Date;
  - (b) fire and extended insurance coverage on all property of Mill Market or for which Mill Market is legally liable, or which is installed by or on behalf of Mill Market, including without limitation, stock in trade, furniture, equipment, partitions, trade fixtures and leasehold improvements, in an amount not less than the full replacement cost thereof from time to time; and
  - (c) Any other insurance that the Mill Market or a Tenant like Mill Market should prudently and reasonably maintain given their business operations.
22. Mill Market shall indemnify the City and save it harmless from any and all losses or claims, actions, demands, liabilities and expenses in connection with loss of life, personal injury and/or damage to or loss of property; (a) arising out of any occurrence in or about the Premises; (b) occasioned or caused wholly or in part by any act or omission of Mill Market or anyone from whom it is in law responsible including those business owners using the Premises; (c) arising from any breach by Mill Market of any provision of this Lease; and (d) arising in any way from Mill Market's operation of the Premises. To that end, Mill Market hereby acknowledges and agrees that the City shall be under no liability for injury to any servant, agent or employee of Mill Market or any sublessee, licensee or invitee of Mill Market or for loss of or damage to the property of Mill Market or of any of these persons that is sustained solely as a result of the Premises unless such injury, loss or damage results from the negligence of the City, its agents, servants or employees or other persons for whom it is responsible for in law. Throughout the Term, Mill Market covenants and agrees to indemnify and save the City harmless against any and all liabilities, claims, damages, interest, penalties, fines, monetary sanctions, losses, costs and expenses whatsoever arising from injury to property, death or injury to any person, firm, partnership or corporation for which the City may become liable by reason of any breach, violation or non-performance by Mill Market or its servants, employees, agents, sublessees or licensees or invitees on the Premises of any covenant, term or provision of this Lease as it relates to the Premises unless such injury, loss or damage results from the negligence of the City, its agents, servants or employees or other persons for whom it is responsible for in law. Mill Market shall indemnify and save the City and those for whom the City is legally responsible for all claims, demands and actions arising out of the use of the Premises by Mill Market unless such claims, demands and actions arise as a result of the deliberate or negligent act of the employees, agents or contractors of the City.
23. The City shall insure the building on the Premises for standard perils for its full replacement value. In the event of damage to the Premises due to fire or other insured peril the City shall promptly repair or replace such damage.
24. Mill Market shall be entitled to place and replace signage on the Premises subject to applicable bylaws and the approval of the City acting reasonably.

## **LEASE OF MOBILE RETAIL UNITS**

25. The City shall hereby lease to Mill Market four (4) mobile retail units owned by the City for a term of two (2) years commencing August 1, 2023 (“Mobile Unit Commencement Date”) and ending July 30, 2025 (collectively the “Mobile Unit Term”) under the terms and conditions set out in Clauses 23-32 inclusive and Schedules B and E herein. The Mobile Unit Commencement Date may be changed on the written agreement of the Parties to an earlier date if the Mobile Unit City Property is ready for occupancy. In the event that the Mobile Unit City Property is not ready for occupancy on August 1, 2023, the determination of which shall be made by the City based on the construction taking place at the Downtown Plaza/Mobile Unit City Property, the parties hereto acknowledge and agree to adjust the Mobile Unit Commencement Date accordingly to a date that the Mobile Unit City Property is ready for occupancy. The City delegates the authority to make that determination and adjust the new Mobile Unit Commencement Date to the Deputy CAO, Community Development and Enterprise Services. The City shall not be responsible for any costs, liabilities or expenses incurred by Mill Market as a result of any adjustment of the Mobile Unit Commencement Date and Mill Market undertakes to ensure any sublease entered into for the mobile retail units reflects the need to adjust for a later or earlier Mobile Unit Commencement date without any liability, cost or expenses to the City.
26. Upon conclusion of the Mobile Unit Term, the Mobile Unit Term may be extended (the “Mobile Unit Extended Term”) for up to two periods of five (5) years each, only upon successful negotiations of the parties hereto to the terms and conditions of such Mobile Unit Extended Term(s). To this end, Mill Market shall provide the City with ninety (90) days notice prior to the end of the initial Mobile Unit Extended Term of its desire to enter into such negotiations and thereafter if such notice is provided, negotiations shall ensue.
27. Mill Market shall be fully responsible for all administrative requirements, tasks and responsibilities related to the lease of the four (4) mobile retail units. To that end, Mill Market shall keep the revenue associated with the four (4) mobile retail units for the Mobile Unit Term until the end of the Mobile Term or any earlier termination of same in accordance with this Lease. It is the parties expectation that the costs incurred by Mill Market to administer the mobile retail units shall equal the rental revenue. At the end of each fiscal year in the Mobile Unit Term, Mill Market shall provide the City with a summary of Revenues and Expenses, a full accounting and any and all necessary documentation as may be requested by the City to assess the revenues earned and expenses incurred from these mobile retail units.
28. Any lease of the four (4) mobile retail units by the City to Mill Market as set out in Clause 23 herein may be terminated by the City upon ninety (90) days’ written notice to Mill Market of its intent to terminate at the City’s sole discretion. Again, Mill Market undertakes to ensure any sublease entered into for the mobile retail units contains an eighty-five (85) day termination clause by Mill Market in the event that the City exercises its rights herein to terminate the Mobile Unit Term. In the event that there are arrears of any fees (ie. electricity, water or other services commonly known as utilities) as set out in Schedule “E”, Section 5, then Mill Market shall be fully responsible for same, and the City shall have the right to terminate the lease of the lease of four (4) mobile retail units on thirty (30) days notice.
29. The four (4) mobile retail units shall be placed by the City at the locations identified in red on Schedule “B” to this Lease. The four (4) mobile vending units shall not be moved by Mill Market at any time during the Mobile Unit Term.
30. Mill Market shall be responsible to pay any taxes that may be assessed as a result of the mobile units and any revenues earned from same.



31. The Mill Market shall issue and complete a Request for Proposals (“RFP”) process to sublease the four (4) mobile retail units referred to herein on the following basis:
  - a. The RFP process shall be overseen and organized by Mill Market;
  - b. The Evaluation Committee shall consist of a total of five (5) individuals, specifically the Mill Market shall have three (3) representatives and the City shall have two (2) representatives on the Evaluation Committee;
  - c. The Evaluation criteria shall be agreed upon by the City and Mill Market prior to release of the RFP. As it relates to the City, delegated authority to select the City Representatives on the Evaluation Committee and approve the Evaluation Criteria shall reside with the Deputy CAO, Community Development and Enterprise Services; and
  - d. The RFP shall advise the potential proponents that the sublease of the mobile retail units shall be subject to the terms and conditions set out in Schedule “E” hereto.
  
32. In the event that the RFP does not result in any subleases for the mobile retail units, the parties hereto acknowledge and agree that this Lease as it relates to the Mobile Units and the Mobile Unit Term shall automatically terminate. In the event that the RFP does not result in all four (4) mobile retail units being subleased, the parties hereto acknowledge and agree that this Lease shall terminate as it relates to the mobile retail units not subleased and apply to only those mobile retail units so subleased. In the further event that the RFP results in RFP submissions that the Evaluation Committee referred to in Section 31 herein recommends that the fifth (5th) mobile retail unit, specifically the unit set out in green in Schedule B hereto, be subleased to Mill Market, then the following shall apply:
  - a. The Evaluation Committee shall make the recommendation to the Deputy CAO, Community Development and Enterprise Services and provide supporting documentation and any information necessary or requested by the Deputy CAO, Community Development and Enterprise Services to complete the review referenced in Section 32(b) and (c) herein;
  - b. The Deputy CAO, Community Development and Enterprise Services shall review the recommendation of the Evaluation Committee and shall have delegated authority to decide if the fifth (5) mobile retail unit should be made available to Mill Market to Lease under the same terms and conditions as set out in Section 25-35 inclusive herein, along with the Schedules to this Lease;
  - c. If, upon reviewing the matter in Section 32(b), the Deputy CAO, Community Development and Enterprise Services determines that the fifth (5th) mobile retail unit should be made available to Mill Market to Lease, the fifth (5th) mobile retail unit shall be leased to Mill Market under the same terms and conditions as set out in Sections 25-35 inclusive herein, along with the Schedules to this Lease and therefore any reference to four (4) mobile retail units in this Lease and Schedules hereto shall be deleted and replaced with five (5) mobile retail units. If the Deputy CAO, Community Development and Enterprise Services determines that the fifth (5<sup>th</sup>) mobile retail unit should not be made available to Mill Market to Lease, the City will proceed with its own arrangements as it relates to that fifth (5) mobile retail unit; and
  - d. The parties acknowledge and agree that the decision of the Deputy CAO, Community Development and Enterprise Services as set out in this section is final.
  
33. Mill Market agrees to maintain at all times during the currency of this Lease of Mobile Units, the following insurance as it relates to the mobile retail units it leases from the City:
  - a. Tenant liability insurance;
  - b. a minimum of Five Million (\$5,000,000.00) Dollars comprehensive general liability insurance in respect of personal injury, death, loss or damage of or to any person or property of third parties, with insurers licenced to conduct business in Ontario. The City shall be added as an Additional Insured to the required general liability policy and no such policy shall be cancelled or allowed to lapse without at least thirty (30) days written notice having been given to the City. An Insurance Certificate, on the C.S.I.O.

form and satisfactory to the City's Risk Manager, shall be provided to the City prior to the commencement of the Licence Date;

- c. fire and extended insurance coverage on all property of Mill Market or for which Mill Market is legally liable, or which is installed by or on behalf of Mill Market including without limitation, stock in trade, furniture, equipment, partitions, trade fixtures and leasehold improvements, in an amount not less than the full replacement cost thereof from time to time; and
  - d. any other insurance that the Mill Market or a Tenant like Mill Market should prudently and reasonably maintain given their business operations
34. Mill Market shall ensure that there is no alcohol sold, served or consumed at the mobile retail units, interior or exterior at any time during the Term unless all necessary AGCO licences, permits and requirements have been secured and adhered to, and the mobile retail units is designated by the City as a facility where alcohol use and consumption is permitted in the City's Alcohol Risk Management Policy. Thereafter, Mill Market shall ensure that any serving and consumption of alcohol at the mobile retail units complies in all respects with the City's Alcohol Risk Management Policy.
35. Mill Market shall ensure that any sublease contains the terms and conditions as outlined in Schedule "E" to this Lease. Mill Market undertakes to be fully responsible to the City for all matters as set out in Schedule "E" to this Lease. Mill Market shall provide the City with a copy of all subleases and any other information as may be requested by the City in relation to same upon request by the City.

#### **TERMINATION**

36. (i) An Act of Default has occurred when:
- a. Mill Market has failed to make the necessary payments as set out in the Lease for a period of sixty (60) consecutive days, regardless of whether a demand for payment has been made or not;
  - b. Mill Market or any licensee/sublessee has breached its covenants or any of the terms and conditions set out in this Lease or any sublease;
  - c. Mill Market has become bankrupt or insolvent, has had its properties seized or attached in satisfaction of a judgment and/or had a receiver appointed;
  - d. Mill Market is no longer insured and does not have the financial wherewithal to cover or respond to claims;
  - e. There is substantial breakdown in the relationship between the City and Mill Market; and/or
  - f. The Premises, Mobile Unit City Property and/or any Mobile Retail Unit is used by any other person or persons, or for any other purpose than as provided for in this Lease without the written consent of the City.
- (ii) If and whenever an Event of Default occurs, then, without prejudice to any other rights which it has pursuant to this Lease or at law, the City shall have the following rights and remedies, which are cumulative and not alternative:
- a. to terminate this Lease by notice to Mill Market or to re-enter the Premises, Mobile Unit City Property and Mobile Retail Units themselves and repossess them and, in either case, enjoy them as of its former estate, and to remove all persons and property from the Premises, Mobile Unit City Property and Mobile Retail Units themselves, and store such property at the expense and risk of Mill Market or sell or dispose of such property in such manner as the City sees fit without notice to Mill Market;
  - b. to enter the Premises, Mobile Unit City Property and Mobile Retail Units themselves as agent of Mill Market to do any or all of the following: (i) relet the Premises, Mobile Unit City Property and Mobile Retail Units themselves and equipment for whatever length and on such terms as the City, in its discretion, may determine, and to receive the rent therefor; (ii) take possession of any property of the Mill Market on the Premises, Mobile Unit City Property and Mobile Retail Units themselves, store such

- property at the expense and risk of Mill Market, or sell or otherwise dispose of such property in such manner as the City sees fit, without notice to Mill Market;
- c. to recover from Mill Market all damages, costs and expenses incurred by the City as a result of any default by Mill Market including, if the City terminates this Lease, any deficiency between those amounts which would have been payable by Mill Market for the portion of the Term following such termination and the net amounts actually received by the City during such period of time with respect to the Premises and Mobile Unit City Property; and
  - d. to recover from Mill Market the full amount of the payments due under the terms of the Lease.

The City shall provide with Notice in accordance with Section 50 herein that an Act of Default has occurred and provide particulars of the Act of Default prior to exercising its rights under this Lease. The parties acknowledge and agree that such termination shall proceed as termination for cause herein given the Act(s) of Default that occurred.

- 37. This Lease may also be terminated by either the City or Mill Market without cause by either party providing Notice in accordance with Section 50 herein to the other party of intention to exercise this right to terminate this Lease anytime after ten (10) years from the Commencement Date and upon one (1) year written notice to the other party.
- 38. Upon termination of this Lease, any and all payments owed by Mill Market for the entire duration of the Lease, including but not limited to rent payable under Sections 2-5 of the Lease, shall immediately become due and payable regardless of the termination of the Lease. For clarity sake, Mill Market shall be obligated to pay the rent payable under Sections 2-5 of the Lease even though the Lease has been terminated and this obligation shall survive the termination of this Lease.

#### **GENERAL**

- 39. Upon the expiry of the Term and the Mobile Unit Term as the case may be, or earlier termination as provided for in this Lease, Mill Market agrees peaceably to surrender the Premises and Mobile Unit City Property, as applicable, including any alterations or additions made thereto, to the City in a state of good repair, reasonable wear and tear and damage by fire lightning and storm only excepted.
- 40. Mill Market shall give reasonable written notice to the City of any substantial damage that occurs to the Premises and the Mobile Units from any cause.
- 41. During the Term and the Mobile Unit Term as the case may be, Mill Market shall not make any alterations or additions to the Premises and the Mobile Retail Units without first submitting to the City a plan showing the proposed alterations or additions and the City has approved same. Any and all alterations or additions to the Premises and Mobile Retail Units must comply with all applicable building code standards, legislation and by-laws and shall be at Mill Market's cost.
- 42. Mill Market agrees at its own expense and by whatever means may be necessary immediately to obtain the release or discharge of any encumbrance that may be registered against the Premises and/or the Mobile Unit City Property and the Mobile Retail Units themselves in connection with any additions or alterations made by Mill Market and/or any licensee or sublease or in connection with any other activity of Mill Market.
- 43. Mill Market shall not bring onto the Premises, Mobile Unit City Property or the Mobile Retail Units themselves any machinery, equipment or other thing that might in the opinion of the City, by reason of its weight, size or use, damage the Premises, Mobile Unit City Property or the Mobile Retail Units themselves and if the Premises, Mobile Unit City Property or the Mobile Retail Units are damaged or overloaded, Mill Market shall restore the affected area immediately or pay to the City the cost of restoring the affected area.

44. Mill Market acknowledges that its obligations to insure and indemnify the City shall extend beyond Mill Market's vacancy of the Premises, Mobile Unit City Property and the Mobile Retail Units themselves when the damage is due to Mill Market's actions or negligence or that of its permitted licencees and/or subleasees.
45. Mill Market acknowledges that the City shall not be liable for any damage resulting from the interruption of Mill Market's business caused by fire or other hazards (whether insured or not) or interruption of utilities or for any indirect or consequential damages, whether or not attributable to the negligence of the City, and Mill Market does hereby expressly release the City of and from any and all liability for such damage.
46. Mill Market shall pay to the City all damages, costs and expenses (including, without limitation, all legal fees on a full indemnity basis) incurred by the City in enforcing the terms of this Lease, or with respect to any matter or thing which is the obligation of the Mill Market under this Lease, or in respect of which the Mill Market has agreed to insure or to indemnify the Landlord and any matters or thing that arises from any licence or sublease by Mill Market to a third party pursuant to this Lease, including but not limited to any breach by a licensee or sublessee of the terms and conditions of this Lease and damages, liabilities, costs and expenses that result from such licence and/or sublease.
47. The parties hereto acknowledge and agree that the Licence to Occupy City Property Agreement between the parties dated April 11, 2022 and approved by Council By-law 2022-060 for the use of one light duty food and retail unit owned by the City at the location South of Ken Danby Way is hereby terminated effective immediately.
48. The parties hereto further acknowledge and agree that the Original Lease Agreement dated July 15, 2019 between the parties is terminated on the Commencement Date.
49. The parties hereto further acknowledge and agree that the Second Amending Lease Agreement dated April 11, 2022 between the parties is terminated on the Mobile Unit Commencement Date. Mill Market shall not sublease the second mobile vending unit located at 35 Canal Drive.
50. Any notice required or permitted to be given by one party to the other pursuant to the terms of this Lease may be given by email to:

To the City at:

Deputy CAO – Community Development and Enterprise Services  
99 Foster Drive, Sault Ste. Marie, ON  
[t.vair@cityssm.on.ca](mailto:t.vair@cityssm.on.ca)

To the Mill Market at:

Claire Denise Martel, Vice Chair  
[rd.martel@gmail.com](mailto:rd.martel@gmail.com)

Such notice will be effective on the date the email is sent.

51. This Lease shall be governed by and construed in accordance with the laws of the Province of Ontario and the laws of Canada in force in the Province of Ontario.
52. No waiver by any party hereto of any breach by any other party of any of its covenants, agreements or obligations contained in this Lease shall be or be deemed to be a waiver of any subsequent breach thereof or the breach of any other covenants, agreements or obligations, nor shall any forbearance by any party hereto to seek a remedy for any breach by any other party be a waiver by the party so forbearing of its rights and remedies with respect to such breach or any subsequent breach. The subsequent acceptance of rent by the City shall not be deemed to be a waiver of any preceding breach by the Mill Market of any term, covenant or condition regardless of the City's knowledge of

such preceding breach at a time of the acceptance of such rent. All rent and other charges payable by the Mill Market to the City hereunder shall be paid without any deduction set off or abatement whatsoever and the Mill Market hereby waives the benefit of any statutory or other right in respect of abatement or set off in its favour at the time hereof or at any future time.

53. In the event of any disputes respecting this Lease, either party may by notice in writing require that the dispute be arbitrated pursuant to the Arbitrations Act (Ontario) and any amendments thereto. Within fourteen (14) days of notice being given of a dispute to be arbitrated, the parties shall agree on a single Arbitrator in Sault Ste. Marie. In the absence of agreement, each Party shall immediately nominate an Arbitrator. Those nominees will confer and select another member of the group to serve as the single Arbitrator for the dispute. Any Arbitrator must have a minimum of ten (10) years' experience as a solicitor or a Judge. The arbitration shall be held at the city of Sault Ste. Marie (or such other location as is agreed upon by the parties) and the procedure for the arbitration shall be as agreed between the parties, or, in the absence of agreement, as determined by the Arbitrator. The parties agree, however, that they desire an efficient arbitration and that any discovery requests, either documentary or oral, should be consistent with this principle. The parties agree that they will use best efforts to ensure that the arbitration hearing is to be conducted within ninety (90) days of the appointment of the Arbitrator. The final decision of the Arbitrator will be furnished to the parties in writing and will constitute a conclusive determination of the issue in question and will be binding upon the parties.
54. There are no covenants, representations, warranties, agreements or other conditions expressed or implied, collateral or otherwise, forming part of or in any way affecting or relating to this Lease, save as expressly set out or incorporated by reference herein. This Lease constitutes the entire agreement duly executed by the parties, and no amendment, variation or change to this Lease shall be binding unless the same shall be in writing and signed by the parties.
55. This Lease may be executed in several counterparts, each of which when so executed shall be deemed to be an original and such counterparts together shall constitute one and the same instrument and shall be effective as of the formal date hereof.

REST OF PAGE INTENTIONALLY LEFT BLANK

56. The parties hereto agree that the signatures and/or initials on this Lease or its acceptance, rejection or modification can be transmitted by FAX or similar electronic transmission and that communication by such means will be legal and binding on all parties as if this document was executed and delivered in the original

In witness thereof, the parties hereto have executed this Lease this 19<sup>th</sup> day of June, 2023.

<b>SIGNED, SEALED AND DELIVERED</b>	)	<b>MILL MARKET SAULT STE. MARIE</b>
	)	
	)	
	)	_____
	)	<b>NAME:</b>
	)	<b>TITLE:</b>
	)	
	)	<b>I have authority to bind the Corporation</b>
	)	
	)	
	)	_____
	)	<b>NAME:</b>
	)	<b>TITLE:</b>
	)	
	)	<b>I have authority to bind the Corporation</b>
	)	
	)	
	)	<b>THE CORPORATION OF THE CITY</b>
	)	<b>OF SAULT STE. MARIE</b>
	)	
	)	
	)	_____
	)	<b>MAYOR – MATTHEW SHOEMAKER</b>
	)	
	)	
	)	_____
	)	<b>CITY CLERK – RACHEL TYCZINSKI</b>

SCHEDULE A



SCHEDULE B

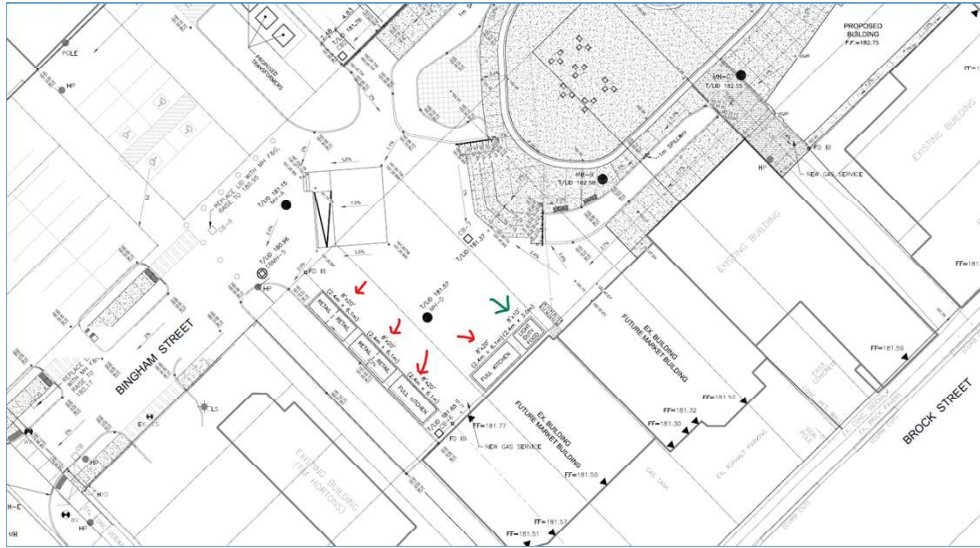



# RURAL ECONOMIC DEVELOPMENT PROGRAM

## AGREEMENT BETWEEN:

HER MAJESTY THE QUEEN IN RIGHT OF ONTARIO  
as represented by the Minister of Agriculture, Food and Rural Affairs

(the "Province")

- and -

MILL MARKET SAULT STE MARIE

CRA # 782297733

(the "Recipient")

In consideration of the mutual covenants and agreements contained in this agreement (the "Agreement") and for other good and valuable consideration, the receipt and sufficiency of which is expressly acknowledged, the Province and the Recipient (the "Parties") agree as follows:

### 1.0 ENTIRE AGREEMENT

1.1 This Agreement, including:

Schedule "A" – General Terms and Conditions,  
Schedule "B" – Operational Requirements and Additional Provisions,  
Schedule "C" – Project Description,  
Schedule "D" – Financial Information,  
Schedule "E" – Payments and Reports,  
And any amending agreement entered into as provided below,

Constitutes the entire agreement between the Parties, with respect to the subject matter contained in this Agreement and supersedes all prior oral or written representation and agreements.

### 2.0 COUNTERPARTS

2.1 This Agreement may only be executed in any number of counterparts, each of which will be deemed an original, but all of which together will constitute one and the same instrument.

2.2 Both Parties consent to and agree to accept electronic signatures, (as defined in the *Electronic Commerce Act*, 2000), as binding the Parties to the terms and conditions of this Agreement.

### 3.0 AMENDING AGREEMENT

3.1 This agreement may only be amended by a written agreement duly executed by the Parties.

### 4.0 ACKNOWLEDGEMENT

4.1 The Recipient acknowledges and agrees:

- (a) It has read and understands the provisions contained in the entire Agreement;
- (b) It will be bound by the terms and conditions in the entire Agreement;
- (c) By receiving and using the Funds provided under this Agreement that it may become subject to the *BPSAA*, the *PSSDA* and the *AGA*;
- (d) The Funds are:

- (i) To assist the Recipient to carry out the Project and not to provide goods or services to the Province, and
- (ii) Funding for the purposes of the *BPSAA*, the *PSSDA* and the *AGA*;
- (e) The Province is not responsible for managing or carrying out the Project; and
- (f) The Province is bound by the *FIPPA* and that any information provided to the Province in connection with the Project or otherwise in connection with the Agreement may be subject to disclosure in accordance with the *FIPPA* or other applicable Requirements Of Law.

**IN WITNESS WHEREOF** the Parties have executed this Agreement on the dates set out below.

**HER MAJESTY THE QUEEN IN RIGHT OF ONTARIO,**  
as represented by the Minister of Agriculture, Food and Rural Affairs

\_\_\_\_\_  
Name: Alan Crawley  
Title: Director, Rural Programs Branch

\_\_\_\_\_  
Date:

I have the authority to bind the Crown pursuant to delegated authority.

**MILL MARKET SAULT STE MARIE**

\_\_\_\_\_  
Name: Brent Lamming  
Title: Board Chair

\_\_\_\_\_  
Date:

\_\_\_\_\_  
Name: Megan Trudeau  
Title: Director and Finance Committee Chair

\_\_\_\_\_  
Date:

I have authority to bind the Recipient.

## SCHEDULE “A” GENERAL TERMS AND CONDITIONS

### ARTICLE 1 INTERPRETATION AND DEFINITIONS

**A.1.1 Interpretation.** For the purposes of interpreting the Agreement:

- (a) Unless specifically defined otherwise in this Agreement, words in the singular include the plural and vice versa;
- (b) Words in one gender include all genders;
- (c) The headings do not form part of this Agreement; they are for reference purposes only and will not affect the interpretation of the Agreement;
- (d) Any reference to dollars or currency will be in Canadian dollars and currency;
- (e) Any reference to a statute means a statute of the Province of Ontario, unless otherwise indicated;
- (f) Any reference to a statute is to that statute and to the regulations made pursuant to that statute as they may be amended from time to time and to any statute or regulations that may be passed that have the effect of supplanting or superseding that statute or regulation unless a provision of the Agreement provides otherwise; and
- (g) All accounting terms will be interpreted in accordance with the Generally Accepted Accounting Principles and all calculations will be made and all financial data to be submitted will be prepared in accordance with the Generally Accepted Accounting Principles.

**A.1.2 Definitions.** In the Agreement, the following terms will have the following meaning:

“**Additional Terms And Conditions**” means the terms and conditions specified in sections A.8.1 and B.2 of this Agreement.

“**AGA**” means the *Auditor General Act, 1990*

“**Agreement**” means this contract between the Province and the Recipient,

“**Arm’s Length**” has the same meaning as set out in the *Income Tax Act (Canada)* as it read on the Effective Date of this Agreement, and as treated or defined under Generally Accepted Accounting Principles.

“**BPSAA**” means the *Broader Public Sector Accountability Act, 2010*.

“**Budget**” means the budget attached to section D.2 of this Agreement.

“**Business Day**” means any working day, Monday to Friday inclusive, excluding statutory holidays of the Province and any other day on which the Province is closed for business.

“**Claim Submission Deadline**” means the date or dates set out under section E.1 (b) of this Agreement.

“**Contract**” means an agreement between the Recipient and a third-party whereby the third-party agrees to provide a good or service for the Project in return for financial consideration that may be claimed by the Recipient as an Eligible Cost.

“**Cost-Share Funding Percentage**” means the percentage the Province will pay toward the Recipient’s Eligible Costs, as set out under section D.1.1 of this Agreement.

“**Effective Date**” means the date on which this Agreement is effective, as set out under section B.1.1 of this Agreement.

**“Eligible Costs”** means those costs set out under in the Guidelines and which the Province has approved as eligible for reimbursement under the terms of this Agreement and also includes any additional costs permitted under section D.2 of this Agreement.

**“Event of Default”** has the meaning ascribed to it in section A.14.1 of this Agreement.

**“Expiration Date”** means the date on which this Agreement will expire, as set out under section B.1.2 of this Agreement, unless amended or terminated prior to this date in accordance with the terms and conditions of this Agreement.

**“FAA”** means the *Financial Administration Act*.

**“Failure”** means a failure to comply with any term, condition, obligation under any other agreement that the Recipient has with Her Majesty the Queen in Right of Ontario or one of Her agencies.

**“Final Report”** means a final Report on the Project in the form set out in section E.2 (a) of this Agreement.

**“FIPPA”** means the *Ontario Freedom of Information and Protection of Privacy Act*.

**“Funding Year”** means:

- (a) In the case of the first Funding Year, the period commencing on the Effective Date and ending on the following March 31, the Expiration Date, or the termination of this Agreement, whichever comes first; and;
- (b) In the case of Funding Years subsequent to the first Funding Year, the period commencing on April 1 following the end of the previous Funding Year and ending on the following March 31, the Expiration Date, or the termination of this Agreement, whichever comes first.

**“Funds”** means the money the Province provides to the Recipient pursuant to this Agreement.

**“Guidelines”** means the documents of the Province setting out the criteria governing the operation of the Program, that were made available on the Program website, at the time the Recipient applied for funding from the Program

**“Holdback”** means the amount set out under section D.1.3 of this Agreement.

**“Incurred”** in relation to costs, means a cost that a Recipient has become liable for, regardless whether actual payment has occurred.

**“Indemnified Parties”** means Her Majesty the Queen in Right of Ontario, Her Ministers, agents, appointees and employees.

**“Ineligible Costs”** means those costs set out in the Guidelines as ineligible for reimbursement by the Province and includes any additional costs identified as ineligible under section D.2.2 of this Agreement.

**“Maximum Funds”** means the maximum amount of Funds the Province will provide to the Recipient under this Agreement, as set out under section D.1.2 of this Agreement.

**“Minister”** means the Minister of Agriculture, Food and Rural Affairs or such other Minister who may be designated from time to time as the responsible Minister in relation to the Program in accordance with the *Executive Council Act*, R.S.O. 1990, c. E. 25, as amended.

**“MFIPPA”** means the *Municipal Freedom of Information and Protection of Privacy Act*.

**“Notice”** means any communication given or required to be given pursuant to this Agreement.

**“Notice Period”** means the period of time within which the Recipient is required to remedy an Event of Default, and includes any such period or periods of time by which the Province considers it reasonable to extend that time.

**“Parties”** means the Province and the Recipient.

**“Party”** means either the Province or the Recipient, unless the context implies otherwise.

“**Program**” means the program created by the Province entitled Rural Economic Development Program under *Order-in-Council 201/2011*, as amended.

“**Project**” means the undertaking described in Schedule “C” of this Agreement.

“**Project Approval Date**” means the same as the Effective Date, as set out in section B.1.1 of this Agreement.

“**Project Completion Date**” means the date that the Recipient must complete its Project under this Agreement, as set out in section B.1.3 of Schedule “B” of this Agreement.

“**PSSDA**” means the *Public Sector Salary Disclosure Act, 1996*.

“**Reports**” means the reports set out under Schedule “E” of this Agreement.

“**Requirements of Law**” means all applicable statutes, regulations, by-laws, ordinances, codes, official plans, rules, approvals, permits, licenses, authorizations, orders, decrees, injunctions, directions and agreements with all authorities that now or at any time hereafter may relate to the Recipient, the Project, the Funds and this Agreement. Without limiting the generality of the foregoing, if the Recipient is subject to the *BPSAA*, the *PSSDA* or any other type of broader public sector accountability legislative provisions, those broader public sector accountability legislative provisions are deemed to be a Requirement of Law.

“**Term**” means the period of time beginning on the Effective Date of this Agreement and ending on the Expiration Date or the termination of this Agreement, whichever is shorter.

“**Timelines**” means the Project schedule set out in Schedule “B”.

- A.1.3 Conflict.** Subject to section 8.1 of Schedule “A” of this Agreement, in the event of a conflict between this Schedule “A” of the Agreement and any other Schedule of this Agreement, the terms and conditions set out under this Schedule “A” of the Agreement will prevail.

## ARTICLE A.2 REPRESENTATIONS, WARRANTIES AND COVENANTS

**A.2.1 General.** The Recipient represents, warrants and covenants that:

- (a) It is, and will continue to be for the Term of this Agreement, an eligible applicant as described in the Guidelines with full power to fulfill its obligations under this Agreement;
- (b) It has, and will continue to have for the Term of this Agreement, the experience and expertise necessary to carry out the Project;
- (c) It has the financial resources necessary to carry out the Project and is not indebted to any person(s) to the extent that that indebtedness would undermine the Recipient’s ability to complete the Project by the Project Completion Date;
- (d) It is in compliance with all Requirements of Law and will remain in compliance with all Requirements of Law for the Term related to any aspect of the Project, the Funds or both for the term of this Agreement; and
- (e) Unless otherwise provided for in this Agreement, any information the Recipient provided to the Province in support of its request for Funds, including any information relating to any eligibility requirements, was true and complete at the time the Recipient provided it.

**A.2.2 Execution of Agreement.** The Recipient represents and warrants that it has:

- (a) The full power and authority to enter into this Agreement; and
- (b) Taken all necessary actions to authorize the execution of this Agreement.

**A.2.3 Governance.** The Recipient represents, warrants and covenants that it has, and will maintain, in writing, for the term of this Agreement:

- (a) A code of conduct and ethical responsibilities for all persons at all levels of the Recipient's organization;
- (b) Procedures to ensure the ongoing effective functioning of the Recipient;
- (c) Procedures to enable the Recipient to manage the Funds prudently and effectively;
- (d) Procedures to enable the Recipient to successfully complete the Project;
- (e) Procedures to enable the Recipient to, in a timely manner, identify risks to the completion of the Project and develop strategies to address those risks;
- (f) Procedures to enable the preparation and delivery of all Reports required under this Agreement; and
- (g) Procedures to enable the Recipient to deal with such other matters as the Recipient considers necessary to ensure that the Recipient carries out its obligations under this Agreement.

**A.2.4 Supporting Documentation.** Upon request, and within the time period indicated in the Notice, the Recipient will provide the Province with proof of the matters referred to in this Article 2 of Schedule "A" of this Agreement.

**A.2.5 Additional Covenants.** The Recipient undertakes to advise the Province within five (5) Business Days of:

- (a) Any changes that affect its representations, warranties and covenants under sections A.2.1, A.2.2 or A.2.3 of this Agreement during the Term of the Agreement;
- (b) Any actions, suits or other proceedings which could or would reasonably prevent the Recipient from complying with the terms and conditions of this Agreement; and
- (c) Any change in ownership or ownership structure.

### **ARTICLE A.3 FUNDS AND CARRYING OUT THE PROJECT**

**A.3.1 Funds Provided.** The Province will:

- (a) Provide Funds to the Recipient up to the Maximum Funds, based on the Cost-Share Funding Percentage, for the sole purpose of carrying out the Project;
- (b) Provide the Funds to the Recipient in accordance with section D.2 of this Agreement provided that the Recipient makes claims for payment of Funds in accordance with section E.1 of this Agreement;
- (c) Provide funding as long as the total combined amount of provincial and federal assistance for the Eligible Costs actually incurred and paid by the Recipient do not exceed ninety per cent (90%) of those costs; and
- (d) Deposit the Funds into an account designated by the Recipient, provided that account:
  - (i) Resides at a Canadian financial institution, and
  - (ii) Is in the name of the Recipient.

**A.3.2 Limitation On Payment Of Funds.** Despite section A.3.1 of this Agreement:

- (a) The Province is not obligated to provide any Funds to the Recipient until the Recipient provides the insurance certificate or other proof as the Province may request pursuant to section A.10.2 of this Agreement;
- (b) The Province is not obligated to provide any Funds until it is satisfied with the progress of the Project;
- (c) The Province may adjust the amount of Funds it provides to the Recipient without liability, penalty or costs in any Funding Year based upon the Province's assessment of the information provided by the Recipient pursuant to Article A.6 of this Agreement;
- (d) If, pursuant to the *FAA*, the Province does not receive the necessary appropriation from the Ontario Legislature for payment under this Agreement, the Province is not obligated to make any such payment, and, as a consequence, the Province may:
  - (i) Reduce the amount of Funds and, in consultation with the Recipient, change the Project without liability, penalty or costs; or
  - (ii) Recover Funds already paid to the Recipient; or
  - (iii) Terminate the Agreement pursuant to section A.13.1 of this Agreement;
- (e) The Province shall impose a Holdback on any payment of Funds and will not be obligated to pay that Holdback to the Recipient until after the Province approves the Recipient's Final Report pursuant to Article A.6 of this Agreement; and
- (f) The Province is not obligated to pay interest on the Holdback as described in (e) or any other payments under this Agreement.

**A.3.3 Use Of Funds And Project.** The Recipient will:

- (a) Carry out the Project in accordance with the terms and conditions of this Agreement;
- (b) Complete the Project by the Project Completion Date;
- (c) Not use the Funds for Ineligible Costs;
- (d) Use the Funds only:
  - (i) For Eligible Costs that are necessary for the purposes of carrying out the Project; and
  - (ii) For those activities set out in section C.3. of this Agreement; and
- (e) Use the Funds only in accordance with the Budget.

**A.3.4 Province's Role Limited To Providing Funds.** For greater clarity, the Province's role under this Agreement is strictly limited to providing Funds to the Recipient for the purposes of the Project and the Province is not responsible for carrying out the Project. Without limiting the generality of the foregoing, the fact that the Province may conduct reviews and/or audits of the Project as provided for in this Agreement or issues directions, approves changes to the Project or imposes conditions upon an approval in accordance with the terms and conditions of this Agreement will not be construed by the Recipient as the Province having a management, decision-making or advisory role in relation to the Project. The Recipient further agrees that the Recipient will not seek to include the Province as a decision-maker, advisor or manager of the Project through recourse to a third party, court, tribunal or arbitrator.

**A.3.5 No Changes.** The Recipient will not make any changes to the Project, including to the Budget or timelines, without the prior written consent of the Province.

**A.3.6 No Payment of Funds until Eligible Expenses are approved.** The Province will provide the Funds to the Recipient for Eligible Costs upon receipt of proof of the expense and according to the Budget only. The Province shall not advance any of the Funds to the Recipient.

- A.3.7 No Provincial Payment Of Interest.** The Province is not required to pay interest on any Funds under this Agreement. For greater clarity, this includes interest on any Funds that the Province has withheld paying to the Recipient.
- A.3.8 Maximum Funds.** The Recipient acknowledges and agrees that the Funds available to it pursuant to this Agreement will not exceed the Maximum Funds.
- A.3.9 Rebates, Credits And Refunds.** The Recipient acknowledges and agrees that the amount of Funds available to it pursuant to this Agreement is based on the actual costs to the Recipient, less any costs, including taxes, for which the Recipient has received, will receive or is eligible to receive, a rebate, credit or refund.
- A.3.10 Funding, Not Procurement.** The funding the Province is providing under this Agreement is funding for the purposes of the PSSDA.

#### ARTICLE A.4

#### RECIPIENT'S ACQUISITION OF GOODS AND SERVICES AND DISPOSAL OF ASSETS

- A.4.1 Acquisition.** If the Recipient acquires goods or services or both with the Funds, it will:
- (a) Do so through a process that is transparent, fair and promotes the best value for the money expended and at competitive prices that are no greater than fair market value after deducting trade discounts and/or any other discounts available to the Recipient; and
  - (b) Comply with any Requirements of Law that may be applicable to how the Recipient acquires any goods or services or both.
- A.4.2 Contracts.** The Recipient will ensure that all Contracts:
- (a) Are consistent with this Agreement;
  - (b) Do not conflict with this Agreement;
  - (c) Incorporate the relevant provisions of this Agreement to the fullest extent possible;
  - (d) Require that any parties to those Contracts comply with all Requirements of Law; and
  - (e) Authorize the Province to perform audits of the parties to those Contracts in relation to the Project as the Province sees fit in connection with Article A.6 of this Agreement .
- A.4.3 Disposal.** The Recipient:
- (a) Will, where Ontario's contribution to the cost of an asset created or purchased using the Funds, exceeds twenty-five thousand dollars (\$25,000.00) at the time of purchase or creation of the asset, retain ownership of the asset for at least two (2) years from the Expiration Date of this Agreement; unless otherwise provided under this Agreement or directed by the Province in writing; and
  - (b) Will not, without the Province's prior written consent, lease or otherwise encumber assets referred to under section A.4.3(a) for at least two (2) years from the Expiration Date of this Agreement unless otherwise provided under this Agreement or as the Province directs in writing.

In the event the Recipient does not comply with section A.4.3 of this Agreement, the Province may recover the Funds provided to the Recipient for the assets referred to under section A.4.3.



**ARTICLE A.5  
CONFLICT OF INTEREST**

- A.5.1 *No Conflict Of Interest.*** The Recipient will carry out the Project and use the Funds without an actual, potential or perceived conflict of interest.
- A.5.2 *Conflict Of Interest Includes.*** For the purposes of this Article, a conflict of interest includes any circumstances where:
- (a) The Recipient; or
  - (b) Any person who has the capacity to influence the Recipient's decisions, has outside commitments, relationships or financial interests that could, or could be seen to, interfere with the Recipient's objective, unbiased and impartial judgment relating to the Project, the use of the Funds or both.
- A.5.3 *Disclosure To The Province:*** The Recipient will:
- (a) Disclose to the Province, without delay, any situation that a reasonable person would interpret as an actual, potential or perceived conflict of interest; and
  - (b) Comply with any terms and conditions that the Province may impose as a result of the disclosure.

**ARTICLE A.6  
REPORTING, ACCOUNTING AND REVIEW**

- A.6.1 *Preparation And Submission.*** The Recipient will:
- (a) Provide any information that is requested by the Province as the Province directs and within the timeline set out in the direction;
  - (b) Submit to the Province (at the address referred to in section B.1.5 of this Agreement) all Reports in accordance with the timelines and content requirements set out in Schedule "E", or in a form as specified by the Province from time to time and ensure that all reports are:
    - (i) Completed to the satisfaction of the Province; and
    - (ii) Signed on behalf of the Recipient by an authorized signing officer and that the accompanying attestation has been completed.
- A.6.2 *Records Maintenance.*** The Recipient will keep and maintain:
- (a) All financial records, including invoices, relating to the Funds or otherwise to the Project in a manner consistent with generally acceptable accounting principles; and
  - (b) All non-financial documents and records relating to the Funds or otherwise to the Project.
- A.6.3 *Inspection.*** The Province, its authorized representatives or an independent auditor identified by the Province may, at their own expense, upon twenty-four (24) hours' Notice to the Recipient during normal business hours, enter upon the Recipient's premises to review the progress of the Project and the Recipient's allocation and expenditure of the Funds and, for these purposes, the Province, its authorized representatives or an independent auditor identified by the Province may take one or more of the following actions:
- (a) Inspect and copy the records and documents referred to in section A.6.2 of this Agreement;
  - (b) Remove any copies made pursuant to section A.6.3(a) of this Agreement from the Recipient's premises; and
  - (c) Conduct an audit or investigation of the Recipient in respect of the expenditure of the Funds, the Project or both.

**A.6.4 Disclosure.** To assist in respect of the rights set out under section A.6.3 of Schedule “A” of this Agreement, the Recipient will disclose any information requested by the Province, its authorized representatives or an independent auditor identified by the Province and will do so in the form requested by the Province, its authorized representatives or an independent auditor identified by the Province, as the case may be.

**A.6.5 No Control Of Records.** No provision of this Agreement will be construed so as to give the Province any control whatsoever over the Recipient’s records.

**A.6.6 Auditor General.** For greater certainty, the Province’s rights to audit under this Article 6 of the Agreement are in addition to any rights provided to the Auditor General.

## **ARTICLE A.7 COMMUNICATIONS**

**A.7.1 Acknowledgement And Support.** Unless otherwise directed by the Province, the Recipient will:

- (a) acknowledge the support of the Province in the form and manner set out under section B.1.6 of this Agreement.
- (b) The Recipient will indicate, in all of its Project-related publications – whether written, oral or visual – that the views expressed in the publication are the views of the Recipient and do not necessarily reflect those of the Province.

**A.7.2 Publication By The Province.** The Recipient agrees that the Province may, in addition to any obligations the Province may have under FIPPA, publicly release information under this Agreement, including the Agreement itself, in hard copy or in electronic form, on the internet or otherwise.

## **ARTICLE A.8 ADDITIONAL TERMS AND CONDITIONS**

**A.8.1 Additional Terms And Conditions.** The Recipient will comply with any Additional Terms and Conditions set out under section B.2 of this Agreement. In the event of a conflict or inconsistency between any of the requirements of the Additional Terms and Conditions and any requirements of this Schedule “A” of the Agreement, the Additional Terms and Conditions will prevail.

## **ARTICLE A.9 INDEMNITY**

**A.9.1 Indemnification.** The Recipient hereby agrees to indemnify and hold harmless the Indemnified Parties from and against any and all direct or indirect liability, loss, costs, damages and expenses (including legal, expert and consultant fees), causes of action, actions, claims, demands, lawsuits or other proceedings, by whomever made, sustained, incurred, brought or prosecuted, in any way arising out of or in connection with the Project or otherwise in connection with this Agreement, unless solely caused by the gross negligence or willful misconduct of the Province.

**A.9.2 Recipient’s Participation.** The Recipient will, at its expense, to the extent requested by the Province, participate in or conduct the defence of any proceeding against any Indemnified Parties and any negotiations for their settlement.

- A.9.3 Province's Election.** The Province may elect to participate in or conduct the defence of any proceeding by providing Notice to the Recipient of such election without prejudice to any other rights or remedies of the Province under this Agreement, at law or in equity. Each Party participating in the defence will do so by actively participating with the other's counsel.
- A.9.4 Settlement Authority.** The Recipient will not enter into a settlement of any proceeding against any Indemnified Parties unless the Recipient has obtained the prior written approval of the Province. If the Recipient is requested by the Province to participate in or conduct the defence of any proceeding, the Province, as the case may be, will co-operate with and assist the Recipient to the fullest extent possible in the proceeding and any related settlement negotiations.
- A.9.5 Recipient's Co-operation.** If the Province conducts the defence of any proceedings, the Recipient will co-operate with and assist the Province, as the case may be, to the fullest extent possible in the proceedings and any related settlement negotiations.

## ARTICLE A.10 INSURANCE

- A.10.1 Recipient's Insurance.** The Recipient represents and warrants that it has, and will maintain for the Term of this Agreement, at its own cost and expense, with insurers having a secure A.M. Best rating of B+ or greater, or the equivalent, all necessary and appropriate insurance that a prudent person carrying out a project similar to the Project would maintain, including commercial general liability insurance on an occurrence basis for third party bodily injury, personal injury and property damage, to an inclusive limit of not less than two million dollars (\$2,000,000.00) per occurrence. The policy will include the following:
- (a) A cross-liability clause;
  - (b) Contractual liability coverage;
  - (c) A thirty (30) day written notice of cancellation or termination provision.
- A.10.2 Proof Of Insurance.** The Recipient will:
- (a) Upon request of the Province provide the Province with either:
    - (i) Certificates of insurance that confirm the insurance coverage required under section A10.1 of this Schedule "A" is in place within the time limit set out in the request, or
    - (ii) Other proof that confirms the insurance coverage required under section A10.1 of this Schedule "A" is in place within the time limit set out in that request; and
  - (b) In the event that:
    - (i) A claim is made against the Province in relation to this Agreement, and
    - (ii) The insurer does not agree to defend and indemnify the Province in relation to that claim, make available to the Province, upon request and within the time limit set out in that request, a copy of each insurance policy the Recipient is required to have under section A.10.1 of this Agreement.

## ARTICLE A.11 TERMINATION ON NOTICE

- A.11.1 Termination On Notice.** The Province may terminate the Agreement at any time without liability, penalty or costs upon giving at least thirty (30) days' Notice to the Recipient.

**A.11.2 Consequences Of Termination On Notice By The Province.** If the Province terminates this Agreement pursuant to section A.11.1 of this Agreement, the Province may take one or more of the following actions:

- (a) Direct that the Recipient does not incur any costs for the Project that are Eligible Costs under this Agreement without the Province's prior written consent;
- (b) Cancel any further payments of the Funds;
- (c) Demand the repayment of any Funds remaining in the possession or under the control of the Recipient; and
- (d) Determine the reasonable costs for the Recipient to wind down the Project, and do either or both of the following:
  - (i) Permit the Recipient to offset such costs against the amount owing pursuant to section A.12.2(b) of this Agreement; and
  - (ii) Subject to section A.3.8 of this Agreement, provide Funds to the Recipient to cover such costs.

## ARTICLE A.12 TERMINATION WHERE NO APPROPRIATION

**A.12.1 Termination Where No Appropriation.** If, as provided for in sections A.3.2(d) of this Agreement, the Province does not receive the necessary appropriation from the Ontario Legislature for any payment the Province is to make pursuant to this Agreement, the Province may terminate the Agreement immediately without liability, penalty or costs by giving Notice to the Recipient.

**A.12.2 Consequences Of Termination Where No Appropriation.** If the Province terminates this Agreement pursuant to section A.12.1 of this Agreement, the Province may take one or more of the following actions:

- (a) Cancel any further payments of the Funds;
- (b) Demand the repayment of any Funds remaining in the possession or under the control of the Recipient; and
- (c) Determine the reasonable costs for the Recipient to wind down the Project and permit the Recipient to offset such costs against the amount owing pursuant to section A.12.2(b) of this Agreement.

**A.12.3 No Additional Funds.** For greater clarity, if the costs determined pursuant to section A.12.2(c) of this Agreement exceed the Funds remaining in the possession or under the control of the Recipient, the Province will not provide additional Funds to the Recipient.

## ARTICLE A.13 EVENT OF DEFAULT, CORRECTIVE ACTION AND TERMINATION FOR DEFAULT

**A.13.1 Events Of Default.** Each of the following events will constitute an Event of Default:

- (a) In the opinion of the Province, the Recipient breaches any representation, warranty, covenant or other term of the Agreement, including failing to do any of the following in accordance with the terms and conditions of this Agreement:
  - (i) Carry out the Project;

- (ii) Use or spend the Funds;
  - (iii) Provide, in accordance with section A.6.1, Reports or any such other reports as may have been requested pursuant to section A.6.1(b), under this Agreement; or
  - (iv) The Recipient fails to follow any directions that the Province provides under this Agreement.
- (b) The Recipient's operations, or its organizational structure, changes such that it no longer meets one or more of the eligibility requirements of the Program under which the Province provides the Funds;
  - (c) The Recipient makes an assignment, proposal, compromise, or arrangement for the benefit of creditors, or a creditor makes an application or an order adjudging the Recipient bankrupt, or applies for the appointment of a receiver; or
  - (d) The Recipient ceases to operate.

**A.13.2 Consequences Of Events Of Default And Corrective Action.** If an Event of Default occurs, the Province may, at any time, take one or more of the following actions:

- (a) Initiate any action the Province considers necessary in order to facilitate the successful continuation or completion of the Project;
- (b) Provide the Recipient with an opportunity to remedy the Event of Default;
- (c) Suspend the payment of Funds for such a period as the Province determines appropriate;
- (d) Reduce the amount of Funds by an amount the Province determines is appropriate, acting reasonably;
- (e) Cancel any further payments of the Funds;
- (f) Demand the repayment of any Funds remaining in the possession or under the control of the Recipient;
- (g) Demand the repayment of an amount equal to any Funds the Recipient used, but did not use in accordance with the terms and conditions of this Agreement;
- (h) Demand the repayment of an amount equal to any Funds the Province provided to the Recipient, even though the Project is partially completed; and
- (i) Terminate this Agreement at any time, including immediately, without liability, penalty or costs to the Province upon giving Notice to the Recipient.

**A.13.3 Opportunity To Remedy.** If, in accordance with section A.13.2(b) of this Agreement, the Province provides the Recipient with an opportunity to remedy the Event of Default, the Province will provide Notice to the Recipient of:

- (a) The particulars of the Event of Default; and
- (b) The Notice Period.

**A.13.4 Recipient Not Remediating.** If the Province has provided the Recipient with an opportunity to remedy the Event of Default pursuant to section A.13.2(b) of this Agreement, and;

- (a) The Recipient does not remedy the Event of Default within the Notice Period;
- (b) It becomes apparent to the Province that the Recipient cannot completely remedy the Event of Default within the Notice Period; or
- (c) The Recipient is not proceeding to remedy the Event of Default in a way that is satisfactory to the Province;

the Province may extend the Notice Period or initiate any one or more of the actions provided for in sections A.13.2(a), (c), (d), (e), (f), (g), (h) and (i) of this Agreement.

**A.13.5 *When Termination Effective.*** Termination under Article A.13 of this Agreement will take effect as set out in the Notice.

#### **ARTICLE A.14 LIMITED TERMINATION OF AGREEMENT**

**A.14.1 *Limited Termination Of Agreement.*** Without limiting the Province's rights under this Agreement, if the Province exercises its right of termination pursuant to Articles A.11, A.12 or A.13 of this Agreement, the Province may limit such termination to one or more activities set out under Article C.3 of this Agreement without terminating this Agreement as a whole.

**A.14.2 *Impact Of Limited Termination Of The Agreement.*** If the Province exercises its right under section A.14.1 of this Agreement, the Province will adjust the Funds being provided under this Agreement to account for the limited termination and the remainder of the Agreement not terminated will remain in effect.

#### **ARTICLE A.15 FUNDS AT THE END OF A FUNDING YEAR**

**A.15.1 *Funds At The End Of A Funding Year.*** Without limiting any rights of the Province under Article A.13 of this Agreement, if the Recipient has not spent all of the Funds allocated for the Funding Year as provided for in the Budget, the Province may, at its sole and absolute discretion, adjust the amount of any further payments of Funds accordingly.

#### **ARTICLE A.16 REPAYMENT**

**A.16.1 *Repayment Of Overpayment.*** If at any time during the Term of this Agreement the Province provides Funds in excess of the amount to which the Recipient is eligible to receive under this Agreement, the Province may:

- (a) Deduct an amount equal to the excess Funds from any further payments of the Funds; or
- (b) Demand that the Recipient pay an amount equal to the excess Funds to the Province.

**A.16.2 *Interest Rate.*** The Province may charge the Recipient interest on any money owing by the Recipient at the then current interest rate charged by the Province of Ontario on accounts receivable.

**A.16.3 *Payment Of Money To Province.*** The Recipient will pay any money owing to the Province by cheque payable to the "Ontario Minister of Finance" and delivered to the Province at the address referred to in section 18.1 of Schedule "A" of this Agreement.

**A.16.4 *Repayment.*** Without limiting the application of section 43 of the *FAA*, if the Recipient fails to repay any amount owing under this Agreement, Her Majesty the Queen in Right of Ontario may deduct any unpaid amount from any money payable to the Recipient by Her Majesty the Queen in Right of Ontario.

**A.16.5 Funds Are Part Of A Social Or Economic Program.** The Recipient acknowledges and agrees that any Funds provided under this Agreement are for the administration of social or economic programs or the provision of direct or indirect support to members of the public in connection with social or economic policy.

## **ARTICLE A.17 NOTICE**

**A.17.1 Notice In Writing And Addressed.** Notice will be in writing and will be delivered by email, postage-paid mail, personal delivery or fax and will be addressed to the Province and the Recipient respectively as set out in section B.1.7 of this Agreement or as either Party later designates to the other by Notice.

**A.17.2 Notice Given.** Notice will be deemed to have been given:

- (a) In the case of postage-paid mail, five (5) Business Days after the Notice is mailed; or
- (b) In the case of email, personal delivery or fax, one (1) Business Day after the Notice is delivered.

**A.17.3 Postal Disruption.** Despite section A.17.2(a) of this Agreement, in the event of a postal disruption,

- (a) Notice by postage-prepaid mail will not be deemed to be received; and
- (b) The Party giving Notice will provide Notice by email, personal delivery or fax.

## **ARTICLE A.18 CONSENT BY PROVINCE AND COMPLIANCE BY RECIPIENT**

**A.18.1 Consent.** When the Province provides its consent pursuant to this Agreement, that consent will not be considered valid unless that consent is in writing and the person providing that consent indicates in the consent that that person has the specific authority to provide that consent. The Province may also impose any terms and conditions on such consent and the Recipient will comply with such terms and conditions.

## **ARTICLE A.19 SEVERABILITY OF PROVISIONS**

**A.19.1 Invalidity Or Unenforceability Of Any Provision.** The invalidity or unenforceability of any provision in this Agreement will not affect the validity or enforceability of any other provision of this Agreement. Any invalid or unenforceable provision will be deemed to be severed.

## **ARTICLE A.20 WAIVER**

**A.20.1 Waivers In Writing.** If a Party fails to comply with any term or condition of this Agreement that Party may only rely on a waiver of the other Party if the other Party has provided a written waiver in accordance with the Notice provisions in Article A.17 of this Agreement. Any waiver must refer to a specific failure to comply and will not have the effect of waiving any subsequent failures to comply. For greater clarity, where the Province chooses to waive a term or condition of this Agreement, such waiver will only be binding if provided by a person who indicates in writing that he or she has the specific authority to provide such a waiver.

**ARTICLE A.21  
INDEPENDENT PARTIES**

**A.21.1 *Parties Independent.*** The Recipient acknowledges and agrees that it is not an agent, joint venturer, partner or employee of the Province and the Recipient will not represent itself in any way that might be taken by a reasonable person to suggest that it is or take any actions that could establish or imply such a relationship.

**ARTICLE A.22  
ASSIGNMENT OF AGREEMENT OR FUNDS**

**A.22.1 *No Assignment.*** The Recipient will not, without the prior written consent of the Province, assign any of its rights or obligations under this Agreement.

**A.22.2 *Agreement Binding.*** All rights and obligations contained in this Agreement will extend to and be binding on the Parties' respective heirs, executors, administrators, successors and permitted assigns.

**ARTICLE A.23  
GOVERNING LAW**

**A.23.1 *Governing Law.*** This Agreement and the rights, obligations and relations of the Parties will be governed by and construed in accordance with the laws of the Province of Ontario and the applicable federal laws of Canada. Any actions or proceedings arising in connection with this Agreement will be conducted in the Courts of Ontario, which will have exclusive jurisdiction over such proceedings.

**ARTICLE A.24  
FURTHER ASSURANCES**

**A.24.1 *Agreement Into Effect.*** The Recipient will provide such further assurances as the Province may request from time to time with respect to any matter to which the Agreement pertains and will otherwise do or cause to be done all acts or things necessary to implement and carry into effect the terms and conditions of this Agreement to their full extent.

**ARTICLE A.25  
JOINT AND SEVERAL LIABILITY**

**A.25.1 *Joint And Several Liability.*** Where the Recipient comprises more than one entity, all such entities will be jointly and severally liable to the Province for the fulfillment of the obligations of the Recipient under this Agreement.

**ARTICLE A.26  
RIGHTS AND REMEDIES CUMULATIVE**

**A.26.1 *Rights And Remedies Cumulative.*** The rights and remedies of the Province under this Agreement are cumulative and are in addition to, and not in substitution of, any of its rights and remedies provided by law or in equity.

**ARTICLE A.27  
JOINT AUTHORSHIP**



**A.27.1 Joint Authorship Of Agreement.** The Parties will be considered joint authors of this Agreement and no provision herein will be interpreted against one Party by the other Party because of authorship. No Party will seek to avoid a provision herein because of its authorship through recourse to a third party, court, tribunal or arbitrator.

## **ARTICLE A.28 FAILURE TO COMPLY WITH OTHER AGREEMENT**

**A.28.1 Other Agreements.** If the Recipient:

- (a) Has committed a Failure;
- (b) Has been provided with notice of such Failure in accordance with the requirements of such other agreement;
- (c) Has, if applicable, failed to rectify such Failure in accordance with the requirements of such other agreement; and
- (d) Such Failure is continuing,

the Province may suspend the payment of Funds under this Agreement without liability, penalty or costs for such period as the Province determines appropriate.

## **ARTICLE A.29 SURVIVAL**

**A.29.1 Survival.** The provisions of this Agreement that by their nature survive the expiration or early termination of this Agreement will so survive for a period of seven (7) years from the date of expiry or termination. Without limiting the generality of the foregoing, the following Articles and sections, and all applicable cross-referenced sections and schedules will continue in full force and effect for a period of seven (7) years from the date of expiry or termination: Articles A.1 and any other applicable definitions, A.9, A.16, A.17, A.19, A.20, A.23, A.24, A.26, A.27, and A.28 as well as sections A.3.2, A.3.4, A.3.8, A.3.9, A.6.1 (to the extent that the Recipient has not provided the Reports to the satisfaction of the Province), A.6.2, A.6.3, A.6.4, A.6.5, A.6.6, A.11.2, A.12.2, A.13.1, A.13.2, A.13.4 of this Agreement and any cross-referenced Schedules therein as well as any other provision in this Agreement that specifically sets out it will survive the expiration or early termination of this Agreement. Despite the above, section A.4.3 of this Agreement shall survive for a period of two (2) years from the date of expiry or termination of this Agreement.

**[REST OF PAGE INTENTIONALLY LEFT BLANK - SCHEDULE "B" FOLLOWS]**

## SCHEDULE “B” OPERATIONAL REQUIREMENTS AND ADDITIONAL TERMS AND CONDITIONS

### ARTICLE B.1 OPERATIONAL REQUIREMENTS

**B.1.1 Effective Date.** The Effective Date of this Agreement is: **April 1, 2022**

**B.1.2 Expiration Date.** The Expiration Date of this Agreement is: **March 31, 2024**

**B.1.3 Project Completion Date.** The Project Completion Date is: **March 31, 2023**

The Project Completion Date may be extended at the request of the Recipient by up to 6 months, provided that:

- (a) The proposed extended date is at least 6 months prior to the Expiration Date
- (b) The request is made in writing to the address in section B.1.6 of this Agreement; and
- (c) The request is approved by the Province in writing.

Extensions of the Project Completion Date not being at least 6 months prior to the Expiration Date will require a written amendment to this Agreement duly executed by the Parties.

**B.1.4 Submission Of Publications For Approval And Reports.** All Reports and Project-related publications under this Agreement shall be submitted to:

**Name:** Ontario Ministry of Agriculture, Food and Rural Affairs  
**Address:** Rural Programs Branch  
 4th Floor NW, 1 Stone Road West  
 Guelph, Ontario N1G 4Y2  
**Attention:** Administrative Service Representative, Agriculture and Rural Programs Unit  
**Email:** RED@ontario.ca

or any other person identified by the Province in writing.

**B.1.5 Recognition Of Provincial Support:** In addition to the requirements under section A.7.1 of this Agreement, the Recipient will acknowledge the Province’s support for the Project in the following manner: “The project is funded in part by the Ontario Ministry of Agriculture, Food and Rural Affairs”.

The Recipient shall install a permanent sign recognizing the Program’s financial support of the Project. The design of the sign and its location is subject to approval by the Province prior to fabrication and installation. The province will reimburse 100 per cent up to \$100 of the total costs of the design, fabrication and installation of the sign once submitting a claim.

**B.1.6 Providing Notice.** All Notices under this Agreement shall be provided to:

	The Province:	The Recipient:
<b>Name:</b>	Ontario Ministry of Agriculture, Food and Rural Affairs	Mill Market Sault Ste Marie
<b>Address:</b>	Rural Programs Branch 4th Floor NW, 1 Stone Road West Guelph, Ontario N1G 4Y2	35 Canal Drive Sault Ste. Marie, Ontario P6A 2P4

**Attention:** Director, Rural Programs Branch Brent Lamming, Board Chair  
**Email:** RED@ontario.ca b.lamming@cityssm.on.ca

or any other person identified by the Parties in writing through a Notice.

## **ARTICLE B.2 ADDITIONAL TERMS AND CONDITIONS**

**B.2.1 Notice Of Recipient's Insolvency.** The Recipient will:

- (a) Provide the Province with Notice at least five (5) Business Days prior to making an assignment, proposal, compromise or arrangement for the benefit of its creditors and will not incur any additional costs for the Project under this Agreement without the Province's prior written consent from the date the Notice is sent to the Province; and
- (b) Provide the Province with Notice within five (5) Business Days of a creditor providing the Recipient with a notice of an intent to enforce security or applying for an order adjudging the Recipient bankrupt or the appointment of a receiver, and will not incur any additional costs under this Agreement without the prior approval of the Province from the date that the Recipient received notice of the creditor's action.

**B.2.2 Special Circumstances** The Parties recognize and acknowledge, that at the time of entering into this Agreement; due to restrictions under the Emergency Management and Civil Protection Act, R.S.O. 1990, and its regulations, put in place in response to an ongoing pandemic known as the CoVID19 pandemic; there were and continue to be limitations on the activities permitted under law (the "Limitations").

**B.2.2.1 Notice of Special Circumstances** Should the Limitations, defined in section B.2.2 of this Agreement, result in a delay in completing the Project or Reports; the Recipient shall immediately notify the Province in writing. The notification from the Recipient should include:

- (i) The specific reasons for the delay;
- (ii) The nature of the delay; and
- (iii) What the Recipient has done and plans to do to mitigate the delay.

**B.2.2.2 Response to Notice of Special Circumstances** Upon receiving a Notice of Special Circumstances (as described in section B.2.2.1 of this Agreement) from the Recipient; the Province will, acting reasonably and in a timely manner, take the following steps;

- (i) Review the notification provided by the Recipient to determine what possible action(s), if any, could be taken to advance the successful completion of the Project;
- (ii) Provide the Recipient with Notice of the Province's determination of what actions will be taken in response to the Notice of Special Circumstances provided by the Recipient, (including any actions the Recipient will be required to take to address the Special Circumstances); and
- (iii) Prepare any amendments to the Agreement which the Province determines at its sole and absolute discretion, are needed.

**[REST OF PAGE INTENTIONALLY LEFT BLANK - SCHEDULE "C" FOLLOWS]**

**SCHEDULE “C”  
PROJECT DESCRIPTION**

- C.1 PROJECT NAME**  
Downtown Market and Community Centre
- C.2 PROJECT STREAM**  
Strategic Economic Infrastructure Stream
- C.3 PROJECT OBJECTIVE**

<b>PROJECT ACTIVITIES ELIGIBLE FOR FUNDING INCLUDE</b>
Facility renovations
Selection of architect
Selection of contractors
long term lease for building use - City of Sault Ste Marie
Recognition Signage

All activities identified above will be completed by the Project Completion Date identified under section B.1.3 of this Agreement.

**[REST OF PAGE INTENTIONALLY LEFT BLANK - SCHEDULE “D” FOLLOWS]**

## SCHEDULE "D"

### PROJECT FINANCIAL INFORMATION

#### ARTICLE D.1 FUNDING INFORMATION

- D.1.1 Cost-Share Funding Percentage.** The Cost-Share Funding Percentage is thirty per cent (30.00%) of incurred paid Eligible Costs up to the Maximum Funds.  
[Note that for payment purposes the percentage is calculated to 10 decimal places and is based on the Maximum Funds against the Project's Total Eligible Costs.]
- D.1.2 "Maximum Funds".** The Maximum Funds the Recipient is eligible to receive from the Province under this Agreement is \$250,000.00
- D.1.3 Holdback.** The Holdback will be up to ten per cent (10%) of Maximum Funds from the final payment of Funds made under this Agreement.

#### ARTICLE D.2 COSTS

- D.2.1 Eligible Costs.** Eligible Costs are those costs or percentage of a cost defined as Eligible Costs in the Guidelines and are limited to costs which the Province has determined, at its sole and absolute discretion, to be costs properly and reasonably incurred, paid or reimbursed by the Recipient, and are necessary for the successful completion of the Project.

For greater clarity, Eligible Costs are those costs that are:

- (a) Incurred by the Recipient in the Province of Ontario on or after the Effective Date and on or before the Project Completion Date;
- (b) Paid by the Recipient to an Arm's Length third party;
- (c) Consistent with the applicable list of Eligible Costs set out in the Guidelines from time to time;
- (d) If related to travel or meals, are consistent with the requirements for travel and meal costs set out in section D.3.1 of this Agreement; and
- (e) In the Province's sole and absolute discretion, directly attributable and necessary for the successful completion of the Project and properly and reasonably incurred, paid or reimbursed by the Recipient.

When purchasing goods or services for the Project, Recipients must follow a process that is transparent and fair, that promotes the best value for the money expended and is at competitive prices that are no greater than the fair market value, including when retaining consultants and contractors.

- D.2.2 Incurring Eligible Costs.** The Recipient will incur Eligible Costs as described in section D.2.1 and in accordance with the following Project Budget chart and no later than by the Project Completion Date:

BUDGET OF PROVINCIAL CONTRIBUTION					
FUNDING YEAR	QUARTER 1 (APR. – JUN.)	QUARTER 2 (JUL. – SEP.)	QUARTER 3 (OCT. – DEC.)	QUARTER 4 (JAN. – MAR.)	FUNDING YEAR TOTAL
<b>The lesser of 30.00% of Eligible Costs, up to the maximum listed below:</b>					
2022-23	\$174,900.00	\$75,100.00	\$0.00	\$0.00	\$250,000.00
<b>MAXIMUM PROVINCIAL FUNDS FOR THE PROJECT</b>					<b>\$250,000.00</b>

**D.2.3** **Ineligible Costs.** Ineligible Costs are any costs that do not meet the requirements for Eligible Costs in section D.2.1 of this Agreement or were not approved by the Province in writing before the Recipient incurred the costs. Ineligible Costs include but are not limited to:

- (a) Any cost incurred prior to the Effective Date or after the Project Completion Date;
- (b) Any cost that will be funded or reimbursed through any other agreement with any third party other than other ministries, agencies and organizations of the Government of Ontario.
- (c) Any cost associated with providing any Reports to the Province pursuant to Schedule “E” or other information required by the Province; and
- (d) Any cost associated with lobbying the Province, including other Ministries, agencies and organizations of the Government of Ontario;

**ARTICLE D.3  
TRAVEL AND MEAL COSTS**

**D.3.1** In order to be considered Eligible Costs, travel and meal costs must be:

- (a) Identified in section C.3 of this agreement
- (b) Incurred only by persons who were hired to work 100 per cent of their time on the Project and whose position is reimbursed by the Funds;
- (c) Aligned with the most current Travel, Meal and Hospitality Expenses Directive (a copy will be provided upon request).

**[REST OF PAGE INTENTIONALLY LEFT BLANK - SCHEDULE “E” FOLLOWS]**

## SCHEDULE “E” PAYMENTS AND REPORTS

**E.1 Claim Submission Requirements.** The Recipient shall submit claims electronically using the Province’s claims portal. Instructions on receiving access to the portal will be provided to the Recipient by the Province at the time of approval. Claims shall be provided as set out in the table below. Claims are not considered delivered until reviewed and approved by the Province.

Name of Claim		Due Date
(a)	Progress Update and Claim Statement	A minimum of one claim must be submitted prior to the final claim, unless waived at the sole and absolute direction of the Province.
(b)	Final claim	The final claim is to be completed and submitted to the Province within three (3) months of the Project Completion Date.

**E.2 Reporting Requirements.** Reports shall be provided as set out in the table below. Reports are not considered delivered until reviewed and approved by the Province.

Name of Report		Due Date
1.	Final Report	The Final Report is to be completed and submitted to the Province on or before: <b>Project Completion + 4 months</b> A copy of the Final Report Template will be provided to you upon request.
2.	Other Reports Any other Report regarding the Project or evidence of project completion that the Province requests.	As directed by the Province.

[REST OF PAGE INTENTIONALLY LEFT BLANK]

**IN WITNESS WHEREOF** the Parties have respectfully signed this Amendment as of the dates indicated below:

**HER MAJESTY THE QUEEN IN RIGHT OF ONTARIO**  
as represented by the Minister of Agriculture, Food and Rural Affairs

  
\_\_\_\_\_  
Name: Alan Crawley  
Title: Director, Rural Programs Branch

Date: Apr 10, 2022

I have the authority to bind the Crown pursuant to delegated authority.

**MILL MARKET SAULT STE MARIE**

  
\_\_\_\_\_  
Name: Brent Lamming  
Title: Chair

Date: April 6, 2022

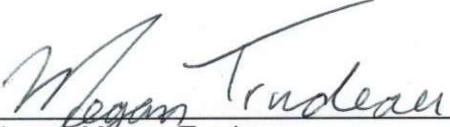
  
\_\_\_\_\_  
Name: Megan Trudeau  
Title: Director and Finance Committee Chair

Date: April 6, 2022

I/We have the authority to bind the Recipient.



## Schedule D

Minister of Intergovernmental Affairs,  
Infrastructure and Communities



Ottawa, Canada  
K1A 0A3

Ministre des Affaires intergouvernementales,  
de l'Infrastructure et des Collectivités

December 7, 2022

Errol TN Caldwell  
Mill Market Sault Ste Marie  
99 Foster Drive  
Sault Ste Marie, Ontario P6A 5X6

Dear Errol TN Caldwell,

I am pleased to inform you of the approval in principle of the funding of the *Mill Market Sault Ste Marie Community Facility* (the “Project”) (AP-000002364) under the terms and conditions of the Green and Inclusive Community Buildings (GICB) program. This approval is given after the review of the Project application, and reliance on the information provided within that application.

Federal funding of the Project from the GICB program will be up to 80% of the total eligible project costs, up to maximum federal funding of \$1,711,596.00. Funding from all sources (federal, provincial, territorial, municipal or otherwise) cannot exceed 100% of the Project’s total eligible costs.

With this approval in principle, eligible costs as determined under the terms and conditions of the GICB program and incurred after April 1, 2021, will be eligible for federal reimbursement subject to the timely execution of a funding agreement. Project costs incurred prior to April 1, 2021, or pursuant to a contract signed prior to April 1, 2021, will be deemed ineligible. If a funding agreement is not signed, the Government of Canada will not reimburse any costs incurred. Once signed, the funding agreement represents the final step of the funding approval process.

In addition to other terms and conditions that will be identified within the funding agreement, the funding will be subject to the following conditions:

- Mill Market Sault Ste Marie will establish and use competitive and transparent tendering processes unless approved in advance by Infrastructure Canada (INFC).

...2

- All ineligible costs, cost increases or overruns, unsecured funding, and any costs related to the ongoing operation and maintenance of the Project, will be the responsibility of Mill Market Sault Ste Marie. You should confirm the eligibility of all items identified in the application prior to incurring expenses.
- In order to receive funding, the project must be authorized or endorsed by a resolution of Council, Band or Board of Directors, as applicable. The resolution must be received before a funding agreement can be executed.

Other specific conditions may also apply, including but not limited to, any applicable environmental assessments and/or consultations with Indigenous organizations which must be completed before funding can be provided.

INFC officials have determined there are no requirements under the *Impact Assessment Act* for this Project.

INFC officials have determined that there is no legal obligation to consult with Indigenous groups since Aboriginal and/or Treaty rights under Section 35 of the *Constitution Act, 1982* are not expected to be adversely impacted by the Project.

Due to the competitive nature of the GICB program, changes to the scope of the Project require careful review and approval by INFC. As your Project is being approved in principle based on the information in your application, please notify officials from the GICB program, in writing, should you expect changes in scope or timing to the Project.

Officials will contact you shortly to move forward with the negotiation of the funding agreement. Further, officials from INFC's Communications Branch will be in contact to review requirements surrounding how a joint funding announcement and all other communications activities will be coordinated, and the roles and responsibilities of each party. Specifically, there is a requirement that all external communication activities about the approval of the Project remain confidential until a joint announcement involving both parties can take place. This relates specifically to a formal public announcement, news release and/or official project milestones (such as ground breaking ceremonies or grand openings).

INFC recognizes that prior to a formal joint announcement, you may have specific activities that you need to undertake in order to ensure that the Project is progressing in a timely manner. Communications of an operational nature (e.g., calls for tender, construction, and public safety notices, etc.) can be carried out. Furthermore, you are permitted to engage stakeholders in order to proceed with planning or consultation, and you may enter into contracts to advance your project's design or other work.

...3

Thank you for your collaboration to date, and I look forward to continuing to work together to conclude a funding agreement for this project in a timely fashion.

Yours sincerely,

A handwritten signature in black ink, appearing to read "D. LeBlanc". The signature is fluid and cursive, with the first letter of the first name being a large, stylized 'D'.

Dominic LeBlanc, P.C., K.C., M.P.

## SCHEDULE E

### TERMS AND CONDITIONS SPECIFIC TO ANY LICENCE AGREEMENT FOR USE AND OCCUPATION OF A MOBILE LIGHT DUTY FOOD AND RETAIL UNIT

The following Terms and Conditions shall form a Schedule to any Licence Agreement between Mill Market and an Approved Proponent, who is a Sublessee or Licensee (hereinafter referred to as the "Awarded Proponent"), and shall govern the use and occupancy of any mobile light duty food and retail unit (the "Mobile Unit"):

- 1) Mill Market shall ensure that the use of the Mobile Unit adheres to the Lease Agreement between Mill Market Sault Ste. Marie and The Corporation of the City of Sault Ste. Marie (the "City") generally. To that end, the Mill Market acknowledges and discloses to the Awarded Proponent that the Mobile Unit is owned by the City and that the City shall enter into a Lease Agreement with the Mill Market which shall cover, among other things, the Lease of Four (4) Mobile Units at the Downtown Plaza. The purposes of the within Licence Agreement is to lease one of the Mobile Units to the Awarded Proponent under the terms and conditions set out in this Licence Agreement;
- 2) Mill Market and any Awarded Proponent shall, jointly or severally, have no right of action of any kind for damages against the City in the event the Mobile Unit is redeployed or delayed by either delivery or installation at the location by the desired date of occupancy. To that end, the Mill Market and Awarded Proponent acknowledge that the City shall determine the date the Mobile Unit is ready for occupancy ("Mobile Unit Commencement Date") and that same is based on the construction taking place at the Downtown Plaza and property to be occupied by the Mobile Unit. The parties hereto acknowledge and agree to adjust the Mobile Unit Commencement Date in the Licence Agreement accordingly to a date that the City determines the Mobile Unit is ready for occupancy. The City shall not be responsible for any costs, liabilities or expenses incurred by Mill Market or any Awarded Proponent as a result of any adjustment of the Mobile Unit Commencement Date. Mill Market and the Awarded Proponent acknowledge and agree that the City may adjust the Mobile Unit Commencement Date at its sole discretion, to a later or earlier date, without any liability, cost or expenses to the City;
- 3) Mill Market and the Awarded Proponent acknowledge and agree that the Mobile Unit shall not be used for the sale or purchase of alcohol, unless approved by the AGCO and the City in advance for said use. Should alcohol be added to any use and occupancy of the Mobile Unit, the insurance requirements as set out in this Schedule shall be a minimum of \$5,000,000.00 Dollars for the Awarded Proponent;
- 4) Mill Market shall ensure that TSSA approval is received in relation to the use and occupation of the mobile light duty food and retail unit;
- 5) Mill Market shall ensure that collection and payment any and all fees related to electricity, water, or other services (commonly known collectively as "utilities"), are remitted on a monthly basis to the relevant utility by the Awarded Proponent as to not create any arrears owed by the City. Any arrears or other fees payable to utilities as a result of the Mobile Unit are the responsibility of the Awarded Proponent, and if not paid, then the responsibility of the Mill Market. At no time shall the City be responsible for these fees. Mill Market and the Awarded Proponent acknowledge and agree that the City may terminate this Licence Agreement that Mill Market has entered into with an Awarded Proponent if there is any such default by Mill Market and/or the Awarded Proponent, with such termination being effective by way of Notice by the City and thereafter termination shall occur thirty (30) days following the date notice has been issued by the City;
- 6) Mill Market shall ensure that any and all Fire Prevention and Protection Act and Fire Code requirements are adhered to, including but not limited to, installation of a "portable" Class K fire extinguisher within the unit that is sized and compatible with the Ansul R102 "fixed" system and that the Awarded Proponent is trained on the use of both the portable and fixed systems;
- 7) Mill Market shall ensure that the use and occupation of the Mobile Unit adheres to any and all Ontario Building Code (OBCA) requirements;
- 8) Mill Market shall ensure that the "Mobile Unit" is approved for the use and occupation by APH before being put in service by any Awarded Proponent;

- 9) Mill Market and the Awarded Proponent shall ensure that no accessory power supply shall be connected to the Mobile Unit, included but not limited to a generator;
- 10) Subject to the hours of operation and dates of use of the Mobile Unit, Mill Market and the Approved Proponent shall ensure that a Food Vendor Licence is obtained and remains current by the Awarded Proponent, as and if required;
- 11) Mill Market and any Awarded Proponent shall be responsible for holding tank use, including filling, emptying and all costs with the same and its maintenance;
- 13) The Awarded Proponent shall indemnify and save harmless the City from all costs and expenses caused to or incurred by the City and from all claims and demands, awards, losses, costs, damages, actions, suits or other proceedings, by whomsoever made, brought or prosecuted in any manner based upon, arising out of or connected with the installation, use, maintenance, presence or removal of the Mobile Unit covered under this Licence Agreement, any damage to property or injury or death to persons by reason of, arising out of or in consequence of breach, violation of non-performance by the Awarded Proponent of any provision of the Licence Agreement, or by reason of or arising out of the use and occupation of the Mobile Unit, or by reason of or arising out of any act, neglect or default by the successful Proponent or any of its agents or employees or any other person or persons, in, on, or about the Mobile Unit and the Downtown Plaza. The Awarded Proponent and Mill Market acknowledge and agree that the intent herein is that the City shall be at no risk or expense to which it would not have been put had the Mobile Unit not been so used or occupied by the Awarded Proponent and this Licence Agreement not been entered into;
- 14) Mill Market shall ensure that the Awarded Proponent will not use or permit the use of the City Property for any purpose other than the purpose herein set out;
- 15) The Awarded Proponent has and shall maintain at all times during the currency of its Licence Agreement and use and occupation of the Mobile Unit, a minimum of TWO MILLION (\$2,000,000.00) Dollars comprehensive general liability insurance in respect of personal injury, death, loss or damage of or to any person or property of third parties, with insurers licenced to conduct business in Ontario. The City shall be added as an Additional Insured to the required liability insurance policy, or policies and no such policy shall be cancelled or allowed to lapse without at least thirty (30) days written notice having been given to the City. An Insurance Certificate, on the C.S. |.O. form and satisfactory to the City's Risk Manager, shall be provided to the City prior to any occupation by an Awarded Proponent of the Mobile Unit, and on renewal of the policy each year during the Term of the Licence Agreement. The Awarded Proponent shall ensure that it secures insurance with deductible amounts that are satisfactory and approved by both Mill Market and the City, specifically the City's Risk Manager;
- 16) The Awarded Proponent shall, and Mill Market shall ensure, that the Awarded Proponent complies with all Laws, By-laws, Rules and Regulations of any governing body respecting the use and occupation of the Mobile Unit;
- 17) The Licence Agreement may be terminated by the City upon providing Mill Market with ninety (90) days' written notice of its intent to terminate at the City's sole discretion. If the City decides to exercise its right to terminate, Mill Market and the Awarded Proponent acknowledge and agree there shall be no recourse and termination shall ensue;
- 18) Mill Market and the Awarded Proponent shall provide the City with a copy of all subleases and any other information as may be requested by the City in relation to the lease of the Mobile Unit, upon request by the City; and
- 19) Mill Market and the Awarded Proponent shall ensure that any contractors that are brought in to complete any work in the Mobile Unit is fully compliant with all Health and Safety and WSIB related matters, and further, be listed as an approved contractor on the City's Contractor Prequalification Program before they are permitted to complete any work on the Mobile Unit. To that end, the Awarded Proponent shall have all contractors complete the forms relevant to the City's Contractor Prequalification Program and submit same to the City for review and approval. Mill Market and the Awarded Proponent acknowledge and agree that a contractor who is not approved as a contractor on the City's Contractor Prequalification Program shall not complete any work on the Mobile Unit at any time during the Term of this Licence Agreement.

- 20) On termination of this Licence Agreement at the end of the Term or earlier Termination of same, the Awarded Proponent shall forthwith remove all equipment, supplies, furniture and belongings of the Awarded Proponent or related to the use and occupation of the Mobile Unit at the Awarded Proponent's sole risk and expense and leave the City Property in a condition satisfactory to the City; provided that if the Awarded Proponent's equipment, supplies, furniture and belongings are not removed by the Licensee within a period of thirty (30) days from the date of such termination, then the City may remove it at the expense and risk of the Awarded Proponent and the Mill Market.
- 21) Mill Market and the Awarded Proponent acknowledge and agree that the indemnities set out herein shall survive the Term of the Licence Agreement.

## APPENDIX 1

### TERMS AND CONDITIONS OF COMMUNITY EVENTS AT THE PREMISES

Pursuant to Section 8 of this Lease, the parties hereto acknowledge and agree that the following terms and conditions shall apply to the use of the Premises for a community event by either the Mill Market or the City:

- (a) The Community Event Organizer shall be required sign a Template Licence and Indemnity Agreement prepared by the City Solicitor or his/her designate confirming that the Community Event Organizer shall indemnify and save harmless the City and the Mill Market from any and all matters related to the Community Event and further specifying:
  - (i) the particulars of the event permitted at the Premises (including but not limited to the date, times, areas of the Premises that can be occupied, and the purpose for the community event, etc.);
  - (ii) that the Community Event Organizer shall be responsible to obtain and any necessary permits for the community event and comply with all necessary legislation and regulations;
  - (iii) that the Community Event Organizer shall be responsible for all matters related to the set up, maintenance, removal, clean up, programming and all costs, expenses and liabilities related to the community event;
  - (iv) that the Community Event Organizer shall be responsible to restore the Premises to its condition prior to the community event at its sole cost, liability and expense;
  - (v) that the Community Event Organizer shall be responsible for any and all taxes, permits, licences assessments of every nature and kind related to the Event;
  - (vi) that the Community Event Organizer shall not assign, transfer or make any other disposition of the Licence or rights conferred thereby; and
  - (vii) any other matters relevant to the community event that are necessary to set out in the Licence and Indemnity Agreement.
  
- (b) The Community Event organizer shall be required to provide a Certificate of Insurance with coverage satisfactory to the City's Risk Manager which shall further name "The Corporation of the City of Sault Ste Marie" and "Mill Market Sault Ste. Marie" as an Additional Insured as it relates to the Event; and
  
- (c) The parties shall each designate a staff member to be responsible for locking up and securing the Premises following the completion of the community event. To that end:
  - (i) If the community event is one that is being requested by the City, the relevant contact is the Manager of Recreation and Culture or his/her delegate; and
  - (ii) If the community event is one that is being requested by the Mill Market, the relevant contact is the Vice Chair.

The City and the Mill Market shall communicate and provide notice in writing prior to the community event setting out who shall be locking up and securing the Premises following completion of the community event.

**LOAN AGREEMENT**

This Loan Agreement is made effective the 20<sup>th</sup> day of March, 2023.

**BETWEEN:**

**THE CORPORATION OF THE CITY  
OF SAULT STE. MARIE**

(herein referred to as the "City")

– and –

**MILL MARKET SAULT STE. MARIE**

(herein referred to as the "Mill Market")

**WHEREAS** the City and Mill Market entered into an original Lease Agreement dated July 15, 2019 (the "Original Lease Agreement") to lease the lands owned by the City known as 35 Canal Drive, Sault Ste. Marie, Ontario, and legally described as PT HUDSON'S BAY COMPANY'S LANDS S/S PORTAGE ST PL TOWN PLOT OF SAULT STE. MARIE PT 10-12 1R5809, PT 2, 3 1R5709, PT 6-10 1R9799; S/T T257669E, for the purpose of a Farmer's Market/Public Market and related ancillary uses and parking for same;

**AND WHEREAS** the Original Lease Agreement was amended by By-law 2020-130 passed on July 13, 2020, whereby pursuant to Section 2(l), additional terms and conditions in response to the COVID-19 pandemic were added to same;

**WHEREAS** the City is the owner of the lands in the City of Sault Ste. Marie municipally known as 73 Brock Street, Sault Ste. Marie, Ontario and legally described as

PIN 31542-0389 (LT), BEING FIRSTLY: LOTS 6-8 PLAN 138 ST. MARY'S; S 1/2 LOT 5 PLAN 138 ST. MARY'S; SECONDLY: 2 FOOT RESERVE PLAN 138 ST. MARY'S; 2 FOOT RESERVE PLAN 366MCD ST. MARY'S; PART LANE PLAN 138 ST. MARY'S; PART LANE PLAN 366MCD ST. MARY'S PART 1,4,5 & 8 1R9480 CLOSED BY T388549; PART LOT 11 PLAN 366MCD ST. MARY'S PART 1 PLAN 1R9277; S/T & T/W T404811; S/T T240452, T240561, T392044, T393283; CITY OF SAULT STE. MARIE

outlined on Schedule "A" attached herein and described as the "Premises";

**AND WHEREAS** Mill Market desires to relocate the Farmer's Market/Public Market from 35 Canal Drive to the Premises once the Premises is ready for occupation and the City is agreeable to same, subject to the terms and conditions as shall be later set out in a Lease Agreement between the parties;

**AND WHEREAS** at the City Council meeting held on February 21, 2023, City Council approved a Resolution, portions thereof relevant to this Loan Agreement being as follows:

Resolved that the report of the Deputy CAO, Community Development and Enterprise Services dated January 9, 2023 be received ...

That Council authorize staff to provide a loan to the Mill Market for booth construction costs of up to \$350,000 and request staff bring back a loan agreement for approval at a future Council meeting (pending NOHFC decision); ...

Further that Council authorize staff to apply as a co-applicant with the Mill Market to the Northern Ontario Heritage Fund;

**AND WHEREAS** Mill Market obtained three (3) quotes for the booth construction and selected a vendor to construct the booths to meet the requirements of their vendors and schedule the construction to align with occupancy at the Premises;

**NOW THEREFORE** in consideration of the sum of One (\$1.00 CDN) Dollar, the receipt of which is hereby acknowledged by the City and the mutual covenants, agreements and promises



hereinafter set forth, the parties for themselves and their respective permitted assigns do hereby covenant and agree with one another as follows:

**LOAN OF \$350,000.00 AND REPAYMENT TERMS**

1. The City shall hereby loan the Mill Market the sum of Three Hundred Fifty Thousand (\$350,000.00 CDN) Dollars (the "Loan") for the costs incurred by Mill Market for the construction of the vendor booths. The Loan shall be interest free and be repayable by Mill Market to the City on the terms set out in Section 2 herein over a period of twenty-five (25) years ("Term of Loan Repayment").
2. Mill Market shall pay the City a monthly loan payment in the sum of One Thousand, One Hundred and Sixty-Six (\$1,166.67) Dollars and Sixty-Seven Cents commencing July 2, 2024 and on or before the 1<sup>st</sup> day of every month thereafter for a period of twenty-five (25) years inclusive until the Loan is fully repaid by Mill Market to the City.
3. Mill Market shall only use the Loan to pay for the costs of constructing the booths which includes security screens and for no other purpose. In the event that the booths cost more than the Loan, Mill Market acknowledges and agrees that Mill Market shall be solely responsible to pay for any such additional costs and the City shall have no responsibility or liability for same.
4. Mill Market and the City shall pursue an application with NOHFC as Co-Applicants for funding for the booth construction. The parties hereto acknowledge and agree that any funds received from NOHFC from this Application shall firstly and immediately be paid to the City to reduce the Loan payable by Mill Market to the City and until the Loan is fully repaid. The parties acknowledge and agree that the Loan shall only be reduced by any amounts received from NOHFC as set out herein, and by any amounts paid by Mill Market directly as loan payment pursuant to Section 2 herein.

**CONSTRUCTION AND INSTALLATION OF THE BOOTHS**

5. Mill Market shall be responsible to pay for all matters related directly and indirectly to the construction, installation, ongoing maintenance and later removal of the booths. The City shall at no time be responsible to pay for anything related directly or indirectly to the construction, installation, ongoing maintenance and later removal of the booths.
6. Mill Market shall be responsible and liable for all costs, taxes, permits, licences, approvals or assessments of every nature and kind whatsoever, in any way arising from the construction and installation of the booths. At no time shall the City be responsible for any matters related to vending, permits, public health requirements, building code requirements, licences, approvals, assessments or costs relating to the construction and installation of the booths at the Premises once a Lease Agreement between the parties has been finalized. Mill Market shall save harmless and fully indemnify the City from and against all losses, costs (including solicitor costs on a substantial indemnity scale basis and disbursements), damages and expenses of every kind or nature which the City may suffer, be at or be put to by reason of or in consequence of the noncompliance by the Mill Market regarding such taxes, permits, licences, approvals and assessments relating to the construction and installation of the booths.
7. Mill Market shall take all steps necessary to ensure that no liens or other encumbrances are filed/registered by the contractor/subcontractors of the booths. In the event that a lien or encumbrance is filed/registered by a contractor/subcontractors of the booths, Mill Market shall take all steps necessary to ensure same is immediately discharged. Mill Market represents that the booths shall constitute "furniture" of the Mill Market and do not form "leasehold improvements" at the Premises.

8. Mill Market represents and warrants that:
  - a. the construction of the booths shall occur outside of the Premises and any other City property;
  - b. the booths shall be installed at the Premises at dates/times satisfactory to the City and only by a contractor that is at the time of installation, an approved Contractor that meets all the criteria set out in the City's Contractor Prequalification Program.
9. This Loan Agreement shall not be assigned by Mill Market without the prior written approval of the City.
10. Subject to Sections 13-16 inclusive herein, the parties hereto acknowledge and agree that the booths shall remain the property of the Mill Market. Upon vacating the Premises at the end or earlier termination of the Lease to be entered between the parties, Mill Market shall ensure that the removal of the booths shall be done in a manner that the Premises is left in a state of repair and cleanliness to the satisfaction of the City and at the Mill Market's sole liability and expense.

#### **INSURANCE AND INDEMNITY**

11. Mill Market agrees to maintain at all times during the currency of this Loan Agreement the following insurance:
  - a. a minimum of Five Million (\$5,000,000.00) Dollars comprehensive general liability insurance in respect of personal injury, death, loss or damage of or to any person or property of third parties, with insurers licenced to conduct business in Ontario. The City shall be added as an Additional Insured to the required liability insurance policy or policies and no such policy shall be cancelled or allowed to lapse without at least thirty (30) days written notice having been given to the City. An Insurance Certificate, on the C.S.I.O. form and satisfactory to the City's Risk Manager, shall be provided to the City prior to the commencement of the Licence Date; and
  - b. fire and extended insurance coverage on all property of Mill Market including the booths, in an amount not less than the full replacement cost thereof from time to time.
12. Mill Market shall indemnify the City and save it harmless from any and all losses or claims, actions, demands, liabilities and expenses in connection with loss of life, personal injury and/or damage to or loss of property; (a) arising out of, directly or indirectly, the construction, installation, ongoing maintenance and later removal of the booths (b) the installation of the booths at the Premises if a Lease Agreement is entered into between the parties; (c) occasioned or caused wholly or in part by any act or omission of Mill Market or anyone from whom it is in law responsible including the contractors/subcontractors retained by Mill Market to construct and install the booths and eventual business owners using the booths; (d) arising from any breach by Mill Market of any provision of this Agreement; and (d) arising in any way from Mill Market's use of the booths. To that end, Mill Market hereby acknowledges and agrees that the City shall be under no liability for injury to any servant, agent or employee of Mill Market or any contractor/subcontractor of the booths, sublessee, licensee, eventual business owner using the booths, or invitee of Mill Market or for loss of or damage to the property of Mill Market or of any of these persons that is sustained. Throughout the Term of the Loan repayment, Mill Market covenants and agrees to indemnify and save the City harmless against any and all liabilities, claims, damages, interest, penalties, fines, monetary sanctions, losses, costs and expenses whatsoever arising from injury to property, death or injury to any person, firm, partnership or corporation for which the City may become liable by reason of any matters related directly or indirectly to this Loan Agreement and the use, construction, installation, maintenance and thereafter removal of the booths.

**Default and Repayment of Entire Loan**

13. The parties hereto acknowledge and agree that the parties shall be entering into a Lease Agreement for Mill Market to occupy the Premises. The Lease Agreement shall contemplate a twenty-five (25) year term. The parties hereto acknowledge and agree that if the parties do not successfully enter into a Lease Agreement for Mill Market to occupy the Premises by July 1, 2023, the Loan herein shall automatically become fully due and owing by the Mill Market and shall bear interest commencing July 1, 2023 at the rate being the Bank of Canada rate as of the date of default plus two (2%) percent. The City shall further have the rights and remedies as set out in Section 16 herein.
14. The parties further acknowledge and agree that in the event that Mill Market vacates the Premises before the end of the twenty-five (25) year term of a Lease Agreement to be entered into by the parties or the City terminates the Lease Agreement early pursuant to the provisions of the Lease Agreement to be entered into between the parties, the Loan shall automatically become fully due and owing by the Mill Market, and shall bear interest commencing the date the Premises is vacated at the rate being the Bank of Canada rate as of the date of default plus two (2%) percent. The City shall further have the rights and remedies as set out in Section 16 herein.
15. An Act of Default has occurred when:
  - a. Mill Market has failed to make the necessary payments as set out in this Loan Agreement for a period of thirty (30) consecutive days, regardless of whether a demand for payment has been made or not;
  - b. Mill Market has breached its covenants or any of the terms and conditions set out in this Loan Agreement;
  - c. Mill Market has become bankrupt or insolvent, has had its properties seized or attached in satisfaction of a judgment and/or had a receiver appointed;
  - d. Mill Market is no longer insured and does not have the financial wherewithal to cover or respond to claims; or
  - e. Mill Market desires to assign the Loan Agreement and the City is not agreeable to same.
16. If and whenever an Event of Default occurs or an event as contemplated in Section 13 or 14 herein occur, then, without prejudice to any other rights which it has pursuant to this Loan Agreement or at law, the City shall have the following rights and remedies, which are cumulative and not alternative:
  - a. to terminate this Loan Agreement by notice to Mill Market and thereafter Mill Market shall be required to immediately repay the Loan in full;
  - b. to terminate this Loan Agreement by notice to Mill Market and seize the booths which shall thereafter remain the sole property of the City and Mill Market shall have no rights to same;
  - c. re-enter the Premises or other property where the booths are located and take possession of the booths or any other property of the Mill Market to satisfy the Loan and the City shall further have the right to sell, re-let or otherwise dispose of the booths in such a manner as the City sees with without notice to Mill Market.
  - d. to recover from Mill Market all damages, costs and expenses incurred by the City as a result of any default by Mill Market and the full repayment of the Loan; and/or
  - e. to recover from Mill Market the full amount of the payments due under the terms of the Lease.
17. Mill Market shall pay to the City all damages, costs and expenses (including, without limitation, all legal fees on a full indemnity basis) incurred by the City in enforcing the terms of this Loan Agreement, or with respect to any matter or thing which is the

obligation of the Mill Market under this Loan Agreement, or in respect of which the Mill Market has agreed to insure or to indemnify the City, and any matters or thing that arises from any contractor/subcontractor's construction and installation of the booths.

**GENERAL**

18. Mill Market shall give reasonable written notice to the City of any substantial damage that occurs to the booths at any time during the Term of the Loan repayment from any cause.
19. During the Term of the Loan Repayment, Mill Market shall not make any alterations or additions to the booths without first submitting to the City a plan showing the proposed alterations or additions and the City has approved same. Any and all alterations or additions to the booths must comply with all applicable building code standards, legislation and by-laws and shall be at Mill Market's cost.
20. Mill Market agrees at its own expense and by whatever means may be necessary immediately to obtain the release or discharge of any encumbrance that may be registered against the Premises, any other City Property and the booths themselves in connection with the construction, installation, maintenance and removal of the booths and this Loan Agreement.
21. Mill Market acknowledges that its obligations to insure and indemnify the City shall extend beyond Mill Market's vacancy of the Premises or other City Property and beyond the use, construction, installation and removal of the booths themselves when the damage is due to Mill Market's actions or negligence or that of its permitted contractors/subcontractors, eventual business owners using the booths, licencees and/or subleasees.
22. Any notice required or permitted to be given by one party to the other pursuant to the terms of this Loan Agreement may be given:
  - To the City at:  
Deputy CAO – Community Development and Enterprise Services  
99 Foster Drive, Sault Ste. Marie, ON  
[t.vair@cityssm.on.ca](mailto:t.vair@cityssm.on.ca)
  - To the Mill Market at:  
Denise Martel, Vice Chair  
[rd.martel@gmail.com](mailto:rd.martel@gmail.com)
23. This Loan shall be governed by and construed in accordance with the laws of the Province of Ontario and the laws of Canada in force in the Province of Ontario.
24. No waiver by any party hereto of any breach by any other party of any of its covenants, agreements or obligations contained in this Loan Agreement shall be or be deemed to be a waiver of any subsequent breach thereof or the breach of any other covenants, agreements or obligations, nor shall any forbearance by any party hereto to seek a remedy for any breach by any other party be a waiver by the party so forbearing of its rights and remedies with respect to such breach or any subsequent breach. The subsequent acceptance of rent by the City shall not be deemed to be a waiver of any preceding breach by the Mill Market of any term, covenant or condition regardless of the City's knowledge of such preceding breach at a time of the acceptance of such rent. All charges payable by the Mill Market to the City hereunder shall be paid without any deduction set off or abatement whatsoever and the Mill Market hereby waives the benefit of any statutory or other right in respect of abatement or set off in its favour at the time hereof or at any future time.
25. There are no covenants, representations, warranties, agreements or other conditions expressed or implied, collateral or otherwise, forming part of or in any way affecting or relating to this Lease, save as expressly set out or incorporated by reference herein. This Loan Agreement constitutes the entire agreement duly executed by the parties, and no

amendment, variation or change to this Loan Agreement shall be binding unless the same shall be in writing and signed by the parties.

- 26. This Agreement may be executed in several counterparts, each of which when so executed shall be deemed to be an original and such counterparts together shall constitute one and the same instrument and shall be effective as of the formal date hereof.
- 27. The parties hereto agree that the signatures and/or initials on this Agreement or its acceptance, rejection or modification can be transmitted by FAX or similar electronic transmission and that communication by such means will be legal and binding on all parties as if this document was executed and delivered in the original

In witness thereof, the parties hereto have executed this Lease this 20th day of March, 2023.

<b>SIGNED, SEALED AND DELIVERED</b>	)	<b>MILL MARKET SAULT STE. MARIE</b>
	)	
	)	<i>C. Denise Martel</i>
	)	_____
	)	<b>NAME:</b> C. Denise Martel
	)	<b>TITLE:</b> Vice Chair
	)	
	)	_____
	)	<b>NAME:</b> Megan Trudeau
	)	<b>TITLE:</b> Treasurer
	)	
	)	<b>We have authority to bind the Corporation</b>
	)	
	)	
	)	<b>THE CORPORATION OF THE CITY OF SAULT STE. MARIE</b>
	)	
	)	
	)	_____
	)	<b>MAYOR – MATTHEW SHOEMAKER</b>
	)	
	)	
	)	_____
	)	<b>CITY CLERK – RACHEL TYCZINSKI</b>

SCHEDULE "A"



Signature:   
Mega Trudeau (Mar 14, 2023 12:49 EDT)

Email: [jbt.met@gmail.com](mailto:jbt.met@gmail.com)







# Mill Market Loan Agreement (1)

Final Audit Report

2023-03-14

Created:	2023-03-14
By:	Claire Denise Martel (rd.martel@gmail.com)
Status:	Signed
Transaction ID:	CBJCHBCAABAAzH8ThopI8EXVDb4Lucc0dmgNPVb2vGHJ

## "Mill Market Loan Agreement (1)" History

-  Document created by Claire Denise Martel (rd.martel@gmail.com)  
2023-03-14 - 4:31:27 PM GMT- IP address: 74.14.56.73
-  Document emailed to jbt.met@gmail.com for signature  
2023-03-14 - 4:33:26 PM GMT
-  Email viewed by jbt.met@gmail.com  
2023-03-14 - 4:48:33 PM GMT- IP address: 67.69.69.207
-  Signer jbt.met@gmail.com entered name at signing as Megan Trudeau  
2023-03-14 - 4:49:35 PM GMT- IP address: 67.69.69.207
-  Document e-signed by Megan Trudeau (jbt.met@gmail.com)  
Signature Date: 2023-03-14 - 4:49:37 PM GMT - Time Source: server- IP address: 67.69.69.207
-  Agreement completed.  
2023-03-14 - 4:49:37 PM GMT

**THE CORPORATION OF THE CITY OF SAULT STE. MARIE**

**BY-LAW 2023-95**

**AGREEMENT**: A by-law to authorize the execution of the Agreement between the City and Ironside Consulting Services Inc. to provide Integrity Commissioner Services for the City of Sault Ste. Marie.

**THE COUNCIL** of The Corporation of the City of Sault Ste. Marie, pursuant to section 9 of the *Municipal Act, 2001*, S.O. 2001, c. 25, **ENACTS** as follows:

1. **EXECUTION OF DOCUMENT**

The Mayor and City Clerk are hereby authorized for and in the name of the Corporation to execute and affix the seal of the Corporation to the Agreement dated June 19, 2023 between the City and Ironside Consulting Services Inc., a copy of which is attached as Schedule "A" hereto. This Agreement is to provide Integrity Commissioner Services for the City of Sault Ste. Marie.

2. **SCHEDULE "A"**

Schedule "A" forms part of this by-law.

3. **EFFECTIVE DATE**

This by-law takes effect on the day of its final passing.

**PASSED** in open Council this 19<sup>th</sup> day of June, 2023.

---

**MAYOR – MATTHEW SHOEMAKER**

---

**CITY CLERK – RACHEL TYCZINSKI**



Schedule "A"

**ENGAGEMENT OF AN INTEGRITY COMMISSIONER  
FOR THE CITY OF SAULT STE. MARIE**

**THIS AGREEMENT** made in duplicate this 19<sup>th</sup> day of June, 2023.

**B E T W E E N:**

**THE CORPORATION OF THE CITY OF SAULT STE. MARIE**

(herein referred to as the "Municipality")

- and -

**IRONSIDE CONSULTING SERVICES INC.**

(herein referred to as the "Integrity Commissioner")

**THIS AGREEMENT WITNESSETH THAT** in consideration of the mutual promises and obligations contained herein, the Parties agree as follows:

**1. TERM**

This agreement (the "Agreement") shall commence August 1, 2023 and end July 30, 2028 (the "Term"), provided that this Agreement is not previously cancelled or terminated by the City in accordance with this Agreement, by operation of law or otherwise, and further provided that the Integrity Commissioner has faithfully complied with and performed all of the covenants and conditions as set out in this Agreement on its part to be performed during the Term.

The Municipality reserves the right to extend the Agreement upon mutual agreement of the Parties hereto and on completion of the Term as set out herein.

**2. DESCRIPTION OF WORK**

The work (the "Work") shall consist of:

- (1) Provide all that is necessary and required to perform all the work shown and described in this Agreement and the Contract Documents, attached as Schedules "A" and "B" to this Agreement.

**3. DOCUMENTS**

- (1) The following list is an exact list of the Contract Documents referred to in Section 2(1) of this Agreement:
  - (a) Proposal for Engagement of an Integrity Commissioner for the City of Sault Ste. Marie (the "Proposal"); and
  - (b) Request for Proposal – Engagement of an Integrity Commissioner for the City of Sault Ste. Marie (the "RFP").
- (2) In the event of a conflict or inconsistency between the Proposal and the RFP, the RFP shall prevail.

**4. EXECUTION OF WORK**

- (1) The Integrity Commissioner shall always carry out the Work in a diligent manner.
- (2) No information about any account shall be given to any person or entity by the Integrity Commissioner either during or after the Term unless prior written authorization to do so has been provided by the Municipality, and only then, in accordance with the *Municipal Freedom of Information and Protection of Privacy Act*, R.S.O. 1990, c. M.56. Upon expiry of this Agreement, the Integrity Commissioner shall provide to the Municipality all accounts and related documentation pertaining to such accounts.

## **5. PAYMENT FOR SERVICES**

- (1) The Integrity Commissioner shall invoice the Municipality monthly for the Work performed for the Municipality at the rates outlined on page 9 [2.9 Fee Schedule] of the Proposal and in accordance with the terms outlined thereto.
- (2) Except where a dispute arises with respect to the accuracy of an invoice, the Municipality shall pay to the Integrity Commissioner the invoiced amount within sixty (60) days of receipt thereof.

## **6. TERMINATION OF AGREEMENT**

- (1) The Municipality may terminate this Agreement, without cause or reason, by giving the Integrity Commissioner thirty (30) days written notice of its intention to do so.
- (2) Upon termination of this Agreement, the Integrity Commissioner and the Municipality shall forthwith pay to each other any monies owing to date, and the Integrity Commissioner shall return any incomplete account materials.

## **7. INSURANCE & INDEMNIFICATION**

- (1) The Integrity Commissioner shall protect itself from and against all claims that might arise from anything done, proposed to be done or omitted to be done by the Integrity Commissioner, its officers, employees, agents or contractors in connection with this Agreement.
- (2) For the purposes of Section 7(1) of this Agreement, and without restricting the generality of that Section, the Integrity Commissioner shall
  - at their expense obtain and keep in force during the term of the Agreement, Commercial General Liability Insurance satisfactory to the (INSERT your Name) and underwritten by an insurer licensed to conduct business in the Province of Ontario. The policy shall provide coverage for Bodily Injury, Property Damage and Personal Injury and shall include but not be limited to:
    - (a) A limit of liability of not less than \$5,000,000 per occurrence with an aggregate of not less than \$5,000,000
    - (b) Add The Corporation of the City of Sault Ste. Marie as an additional insured with respect to the operations of the Named Insured
    - (c) The policy shall contain a provision for cross liability and severability of interest in respect of the Named Insured
    - (d) Non-owned automobile coverage with a limit not less than \$2,000,000 and shall include contractual non-owned coverage (SEF 96)
    - (e) Products and completed operations coverage

- (f) Contractual Liability
- (g) Work performed on Behalf of the Named Insured by Sub-Contractors
- (h) The policy shall provide 30 days prior notice of cancellation

- take out and keep in force Professional Liability insurance in the amount of \$5,000,000 providing coverage for acts, errors and omissions arising from their professional services performed under this Agreement. The policy SIR/deductible shall not exceed \$25,000 per claim and if the policy has an aggregate limit, the amount of the aggregate shall be double the required per claim limit. The policy shall be underwritten by an insurer licensed to conduct business in the Province of Ontario and acceptable to The Corporation of the City of Sault Ste. Marie. The policy shall be renewed for 3 years after contract termination. A certificate of insurance evidencing renewal is to be provided each and every year. If the policy is to be cancelled or non-renewed for any reason, 90-day notice of said cancellation or non-renewal must be provided to the Risk Manager of The Corporation of the City of Sault Ste. Marie. The Corporation of the City of Sault Ste. Marie has the right to request that an Extended Reporting Endorsement be purchased by the (Professional) at the (Professional's) sole expense.

- (3) The Supplier shall defend, indemnify and save harmless The Corporation of the City of Sault Ste. Marie its elected officials, officers, employees and agents from and against any and all claims of any nature, actions, causes of action, losses, expenses, fines, costs (including legal costs), interest or damages of every nature and kind whatsoever, including but not limited to bodily injury, sickness, disease or death or to damage to or destruction of tangible property including loss of revenue or incurred expense resulting from disruption of service, arising out of or allegedly attributable to the negligence, acts, errors, omissions, misfeasance, nonfeasance, fraud or willful misconduct of the Supplier, its directors, officers, employees, agents, contractors and subcontractors, or any of them, in connection with or in any way related to the delivery or performance of this Contract. This indemnity shall be in addition to and not in lieu of any insurance to be provided by the Supplier in accordance with this Contract and shall survive this Contract.

The Supplier agrees to defend, indemnify and save harmless The Corporation of the City of Sault Ste. Marie from and against any and all claims of any nature, actions, causes of action, losses, expenses, fines, costs (including legal costs), interest or damages of every nature and kind whatsoever arising out of or related to the Supplier's status with WSIB. This indemnity shall be in addition to and not in lieu of any proof of WSIB status and compliance to be provided by the Supplier in accordance with this Contract, and shall survive this Contract.

## **8. ASSIGNMENT**

The Integrity Commissioner shall not assign this Agreement or any portion thereof without the prior written consent of the Municipality. In the event that the Municipality consents to such assignment, the Integrity Commissioner shall ensure that any assignee undertaking any of the Integrity Commissioner's obligations hereunder shall be bound by the terms of this Agreement. The Integrity Commissioner shall not be released of its obligation to the Municipality by reason of the assignment, and the Integrity Commissioner shall be deemed liable for any breach of this Agreement, or any legislation or regulation, committed by the assignee.

## **9. MUNICIPALITY AND INTEGRITY COMMISSIONER CONTACT PERSONS**

The following contact persons and addresses shall be used by all Parties for all matters in this Agreement that require the Parties to send documentation to a Party, or to contact a Party:

The Corporation of the City of Sault Ste. Marie  
Rachel Tyczinski, City Clerk  
99 Foster Drive  
Sault Ste. Marie ON P6A 5X6  
Telephone: (705) 759-5391

Ironside Consulting Services Inc.  
Antoinette Blunt  
155 Ironside Drive,  
Prince Township, ON P6A 6K4  
705-779-3223

## 10. INDEPENDENT CONTRACTOR STATUS

- (1) The Integrity Commissioner is an independent contractor and neither the Integrity Commissioner nor the Integrity Commissioner's staff is or shall be deemed to be employed by the Municipality. The Integrity Commissioner reserves the right to determine the method, manner and means by which the services will be performed in accordance with Schedules "A" and "B" attached. Notwithstanding the same, the Integrity Commissioner acknowledges and agrees to discharge its obligations and perform the services set out herein in accordance with the terms of this Agreement (including Schedules "A" and "B" attached), the Municipality's Code of Conduct, and all applicable legislation, including but not limited to the *Municipal Act, 2001* and the *Municipal Conflict of Interest Act*.
- (2) The Integrity Commissioner is not required to perform the services during a fixed hourly or daily time and if the services are performed at the Municipality's premises, then the Integrity Commissioner's time spent at the premises is to be at the discretion of the Integrity Commissioner; subject to the Municipality's normal business hours and security requirements. The Integrity Commissioner hereby confirms to the Municipality that the Municipality will not be required to furnish or provide any training to the Integrity Commissioner to enable the Integrity Commissioner to perform services required hereunder.
- (3) The services shall be performed by the Integrity Commissioner or Integrity Commissioner's staff, and the Municipality shall not be required to hire, supervise or pay any assistants to help the Integrity Commissioner who performs the services under this agreement. The Integrity Commissioner shall not be required to devote the Integrity Commissioner's full time nor the full time of the Integrity Commissioner's staff to the performance of the services required hereunder, and it is acknowledged that the Integrity Commissioner has other Clients and the Integrity Commissioner offers services to the general public.
- (4) The order or sequence in which the work is to be performed shall be under the control of the Integrity Commissioner, except to the extent that the Integrity Commissioner's work must be performed on or with the Municipality's computers or the Municipality's existing software. All materials used in providing the services shall be provided by the Integrity Commissioner.
- (5) The Municipality shall not provide any insurance coverage of any kind for the Integrity Commissioner or the Integrity Commissioner's staff, and the Municipality will not withhold any amount that would normally be withheld from an employee's pay.

**11. AMENDMENTS**

The Municipality and the Integrity Commissioner hereby acknowledge and agree that any future amendments to this Agreement must be made in writing and signed by both Parties.

**12. ENTIRE AGREEMENT**

The Integrity Commissioner acknowledges that there are no covenants, representations, warranties, agreements or conditions expressed or implied, collateral or otherwise forming part of or in any way affecting or relating to this Agreement other than as set out in this Agreement and the Contract Documents, which constitutes the entire agreement between the Parties and which may be modified only as set out in Section 11 of this Agreement.

**13. SUCCESSORS**

The provisions of this Agreement shall be binding upon, and enure to the benefit of, the Parties and their respective successors and, where applicable, permitted assigns.

**14. GOVERNING LAW**

The Parties hereto acknowledge and agree that this Agreement is made in the Province of Ontario and the Courts of the Province of Ontario shall have jurisdiction in reference to any matters herein.

**IN WITNESS WHEREOF** the Parties hereto have signed this Agreement this 19<sup>th</sup> day of June, 2023.

**IRONSIDE CONSULTING SERVICES INC.**

Per: \_\_\_\_\_

Name:

Position:

*I have the authority to bind the Corporation*

**THE CORPORATION OF THE CITY OF SAULT STE. MARIE**

Per: \_\_\_\_\_

MAYOR – MATTHEW SHOEMAKER

Per: \_\_\_\_\_

CITY CLERK – RACHEL TYCZINSKI

*We have the authority to bind the Corporation*

**Request for Proposal**  
City of Sault Ste. Marie  
Engagement of an Integrity Commissioner

**SECTION 3**

**3. FORM OF PROPOSAL**  
**ENGAGEMENT OF AN INTEGRITY COMMISSIONER**  
**FOR THE CITY OF SAULT STE. MARIE**

Ms. Karen Marlow  
Manager of Purchasing  
Civic Centre, Sault Ste. Marie

I/We the undersigned, hereby submit the attached Proposal to satisfy the requirements laid out by the Corporation of the City of Sault Ste. Marie.

I/We have reviewed and understand the Information to Proponents (Section 1) of the RFP and agree to the terms and conditions contained therein in submitting this Proposal.

I/We agree that this Proposal is made without any connection, knowledge, comparison of figures or arrangements with any other person or persons submitting a Proposal for the same purpose and is in all respects fair and without collusion or fraud.

It is further understood and agreed that the lowest or any Proposal will not necessarily be accepted and that the City reserves the right in its absolute discretion to reject any or all Proposals, or accept the Proposal deemed most acceptable to the City. The City further reserves the right to negotiate with the successful Proponent to finalize the terms and conditions of the Proposal.

I/We acknowledge review of **Addenda #.**    **to #.**    issued for this Proposal.

This **"Form of Proposal"** must be completed, legibly signed, and returned as part of the Proposal submission to qualify.

Ironside Consulting Services Inc.  
NAME OF FIRM SEAL

155 Ironside Drive  
ADDRESS

Prince Township  
CITY

*Antoinette Blunt*  
SIGNING OFFICER SIGNATURE  
I have the authority to bind the Corporation

Antoinette Blunt  
SIGNING OFFICER'S NAME (please print)

iconsiderconsult@outlook.com  
PRINCIPAL CONTACT EMAIL

06A 6K4  
POSTAL CODE

\_\_\_\_\_  
WITNESS' SIGNATURE (must be present if Corporate Seal is not affixed to Form of Proposal)

705-779-3223  
TELEPHONE NUMBER

1 May 2023  
DATE

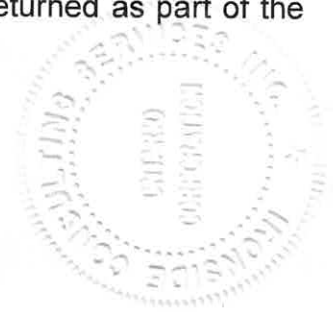

*The Corporation of the  
City of Sault Ste. Marie*

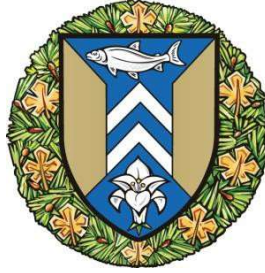

*Corporate Services  
Finance Department  
Purchasing Division*

*Karen Marlow  
Manager of Purchasing*

## **Request for Proposal**

### **ENGAGEMENT OF AN INTEGRITY COMMISSIONER FOR THE CITY OF SAULT STE. MARIE**

---

**File: 2023CRP-CLK-01-P  
April 13, 2023**

**THE CORPORATION OF THE CITY OF SAULT STE. MARIE**

**REQUEST FOR PROPOSAL**

**ENGAGEMENT OF AN INTEGRITY COMMISSIONER**  
**FOR THE CITY OF SAULT STE. MARIE**

---

The Corporation of the City of Sault Ste. Marie invites you to submit a Proposal to provide Professional Services in the role as Integrity Commissioner.

During the period for Proposal preparation, any questions concerning the Terms of Reference requirements should be addressed to Rachel Tyczinski, City of Sault Ste. Marie, [tyczinski@cityssm.on.ca](mailto:tyczinski@cityssm.on.ca).

If you are in a position to bid on this work, the completed Form of Proposal and any required attachments and schedules must be submitted prior to the closing date and time. You are encouraged to make a full copy of the document for your file.

We look forward to receiving your response.

Yours sincerely,

Karen Marlow  
Manager of Purchasing



**1. INFORMATION TO PROPONENTS** .....4

**1.1 Introduction**.....4

**1.2 Date, Place and Methodology for Submitting Proposals**.....4

**1.3 Errors, Omissions, Clarifications** .....5

**1.4 Withdrawal/Decline of Proposal**.....5

**1.5 Informal Proposals**.....5

**1.6 Proposal Evaluation** .....6

**1.7 Site Inspection and Requirements of Work**.....7

**1.8 Proposal Left Open** .....7

**1.9 Schedule** .....7

**1.10 Incurred Costs**.....8

**1.11 Alterations to Documents**.....8

**1.12 Confidentiality & Post-Award Comment**.....8

**1.13 Municipal Freedom of Information & Protection of Privacy Act** .....8

**1.14 Indemnification and Insurance**.....8

**1.15 Agreement for Services**.....9

**Appendix A – Draft Agreement** .....10

**2. TERMS OF REFERENCE**.....15

**2.1 Introduction**.....15

**2.2 Background**.....15

**2.3 Code of Conduct**.....15

**2.4 Project Scope – Role of the Integrity Commissioner**.....15

**2.5 Proponent’s Qualifications**.....16

**2.6 Conflict of Interest** .....17

**2.7 Experience & Reference**.....17

**2.8 Methodology**.....17

**2.9 Fee Schedule** .....17

**3. FORM OF PROPOSAL** .....19

**4. APPENDIXES** .....20

**Appendix 1 - Code of Conduct (Under Review)**.....21

**Appendix 2 – Municipal Act, 2001 .....33**

## **SECTION 1**

### **1. INFORMATION TO PROPONENTS**

#### **1.1 Introduction**

The City of Sault Ste. Marie is requesting proposals from qualified proponents who are interested in serving the City as its Integrity Commissioner. The appointment will be on an as needed basis for a five (5) year term, to commence August 1, 2023.

#### **1.2 Date, Place and Methodology for Submitting Proposals**

Submissions for this Request for Proposal will be accepted in electronic format (preferred) or printed format (addressed as outlined below) until Thursday, May 4, 2023 at 4:00 p.m. local time (Eastern). **Late submissions will not be accepted and may be returned upon request at the Proponent's expense.**

**Electronic submissions** must be sent to the following email address:

[Proposals.Purchasing@cityssm.on.ca](mailto:Proposals.Purchasing@cityssm.on.ca)

with this subject line:

[Proposal – Electronic Submission – Engagement of an Integrity Commissioner,  
File #2023CRP-CLK-01-P](#)

Electronic submissions must be in pdf format only. Links to drop boxes or other forms of cloud storage are not acceptable. Emails including the Proposal are limited to 10 MB or less for mailing purposes. If submission is larger than 10MB, send in multiple emails marked as 1 of #; 2 of #; etc. Electronic submissions must be complete in every way meeting the requirements of printed submission; save and except the provision of multiple copies. The date stamp provided by the City's email server will be the official time of receipt. Proponents should recognize that delays may develop during delivery of electronic submissions of a proposal and submit their proposal well in advance of the time and date set for closing. The City accepts no responsibility for these delays.

Proponents agree to submit a printed original version of their electronically submitted Proposal including all attachments **immediately upon request only** by mail, courier or hand delivery.

**Printed submissions for this Request for Proposal will be considered although it is preferred that an electronic version be submitted.**

**Printed submissions** must be sealed in an envelope or package properly marked as to contents (“Engagement of an Integrity Commissioner, File #2023CRP-CLK-01-P”) and may be delivered by mail, courier, or hand delivery to:

The City of Sault Ste. Marie  
Attn: Manager of Purchasing  
99 Foster Drive – Level 2  
Sault Ste. Marie, Ontario, P6A 5X6

Proposals should be limited to twenty (20) pages, single sided including appendices; a Letter of Introduction; **and required completed Form of Proposal (Section 3)**.

For printed submissions, four (4) complete sets of the Proposal documents are to be submitted – one (1) marked as **“Original”** and three (3) sets marked as **“Copy”**.

The Corporation reserves the right to reject any or all Proposals and the lowest or any Proposal will not necessarily be accepted.

**The Contact Person for this RFP is Rachel Tyczinski, City Clerk, telephone 705-759-5391, email [r.tyczinski@cityssm.on.ca](mailto:r.tyczinski@cityssm.on.ca)**

It will be the Proponent’s responsibility to clarify any questions before submitting a Proposal. A written addendum issued by the **City of Sault Ste. Marie** is the only means of changing, amending or correcting this RFP. In the process of responding to this RFP, the Proponent should not utilize any information obtained outside this protocol.

### **1.3 Errors, Omissions, Clarifications**

During the period for Proposal preparation, any questions concerning the Terms of Reference requirements should be addressed **by email only** to; Rachel Tyczinski, City Clerk, Telephone 705759-5391, email [r.tyczinski@cityssm.on.ca](mailto:r.tyczinski@cityssm.on.ca).

General bidding process inquiries should be directed (by email preferred) to Karen Marlow, Manager of Purchasing; telephone 705-759-5298; email [k.marlow@cityssm.on.ca](mailto:k.marlow@cityssm.on.ca).

### **1.4 Withdrawal/Decline of Proposal**

Proponents will be permitted to withdraw their Proposal, unopened, after it has been deposited, if such a request is received by the City, prior to the time specified for the opening of Proposals.

### **1.5 Informal Proposals**

Proposals are to conform to the terms and conditions set out herein. Proposals which are incomplete, conditional, or obscure, or which contain additions not called for, erasures, alterations, errors, or irregularities of any kind, may be rejected as informal. All Proposals must be legibly signed by an authorized officer of the Proponent's firm.

### **1.6 Proposal Evaluation**

The successful proponent will be selected based on evaluation of the proposal utilizing a rating system which considers the requirements mentioned below. A committee composed of City staff will be used in the selection process. The proponent shall outline:

- 1) Curriculum Vitae for the Proponent, and any persons to which the work may be delegated; requirements of Section 2 – Proponent's Qualifications should be addressed;

Proponent's relevant past experience on similar projects and professional representative experience. Proposals should include details and provide relevant references (minimum of 3) including Contact Names;

- 2) Proposal must include a detailed work program methodology – ensuring quality of work and cost effectiveness; any anticipated assignment of work; setting out proposed response times, and any communication and coordination procedures as appropriate;
- 3) Proposal must include a fee schedule for the required scope of services as outlined in Section 2 - Terms of Reference of the RFP;

The above list of criteria represents areas which are to be specifically addressed in the proposal. The evaluation process will not necessarily be limited to these areas. Other criteria not specifically listed above may also receive consideration. The order in which the criteria are listed does not indicate the weighting of the evaluation.

The City reserves the right, in its sole and absolute discretion to select a preferred Proponent with which to negotiate a final contract, terminate the proposal call or reject any and all Proposals. Negotiations will not constitute a legally binding offer to enter into a contract on the part of the City or the proponent and there will be no legally binding relationship created with any proponent prior to obtaining recommendation approvals and execution of a written agreement.

The City will endeavor to complete the evaluation process within a reasonable time frame. The City reserves the right to contact Proponents to seek clarification of the proposals, as submitted, to assist in the evaluation process. Interviews may be required. **Please see Paragraph 1.10 concerning incurred costs associated with attendance at such interviews.**

**IMPORTANT:** The decision of the City of Sault Ste. Marie with respect to this Request for Proposals is considered final. In submitting a Proposal, Proponents agree that there is no recourse to the City of Sault Ste. Marie for its decision.

### **1.7 Site Inspection and Requirements of Work**

Proponents are required to submit their proposals upon the conditions that they shall satisfy themselves by personal examination of the location of the proposed works, and by such other means, as they may prefer, as to the actual conditions and requirements of the work.

The successful Proponent is required to comply with the requirements of the City's Contractor Pre-Qualification Program prior to the start of any onsite work on this Contract and shall be kept current for the duration of the Contract. These requirements include but are not limited to WSIB Coverage, Liability Insurance Coverage, Accessibility Training, and Safe Work Practices. Furthermore, the City's Vaccination Policy also applies to contractors while they are working on City Workplaces, or directly with our employees. Details regarding compliance with this requirement may be obtained by contacting Shelley Olar, Risk Manager, telephone 705-759-5768 or by email to [s.olar@cityssm.on.ca](mailto:s.olar@cityssm.on.ca). Responsibility for compliance with this requirement for its Subcontractors is the responsibility of the successful Contractor. Failure to comply with the requirements of this Program will result in loss of the contract.

### **1.8 Proposal Left Open**

The Proponent shall keep their Proposal open for acceptance for sixty (60) days after the closing date.

### **1.9 Schedule**

- (A) Release of RFP: April 13, 2023
- (B) Question Close: April 21, 2023
- (C) Submission of Proposal: May 4, 2023
- (D) Recommendation of Award: May 2023
- (E) Commencement of Services: August 1, 2023

The City reserves the right to alter the scheduling of items "D" to "E". Proponents are asked to designate one contact person to whom any additional information deemed to be relevant to the proposal may be communicated. Complete Contact Coordinates including email address shall be included in the Proposal.

### **1.10 Incurred Costs**

The City will not be liable for, nor reimburse any Proponent for costs incurred in the preparation of Proposals or any other costs such as preparation for, and attendance at interviews that may be required as part of the evaluation process.

Whenever possible, at the sole determination of the City, additional information and/or clarifications will be obtained by telephone or other electronic means.

### **1.11 Alterations to Documents**

No electronic reproduction or alteration of the original document will be permitted under any circumstance. The Proponent shall not change the wording of the proposal after submission; and no words or comments shall be added to the general conditions or detailed specifications unless requested by the City for the purpose of clarification.

### **1.12 Confidentiality & Post-Award Comment**

No Proponent shall have the right to review or receive any information with respect to a proposal, documentation, or information submitted by any other Proponent. The content of the proposal, and all documentation, and information shall be held in confidence by the City subject only to the provision of freedom of information and privacy legislation, including without limitation, the *Municipal Freedom of Information and Protection of Privacy Act*.

Post-Award Comment by the City regarding this Request for Proposal will be limited to written notification to all Proponents of the successful Proponent's name and address only – no further debriefing will be provided. **In submitting a Proposal, Proponents acknowledge and agree to this provision.**

### **1.13 Municipal Freedom of Information & Protection of Privacy Act**

The Corporation of the City of Sault Ste. Marie is governed by the provisions of the *Municipal Freedom of Information and Protection of Privacy Act*. All documents submitted to the City in response to this Request for Proposal become the property of the City and as such will be subject to the disclosure provisions of the *Act*. The *Act* gives persons a right of access to information held by the municipality. The right of access is subject to exemptions contained in the *Act*.

### **1.14 Indemnification and Insurance**

The successful Proponent will indemnify and save harmless the City against and from all actions, causes of action, interest, claims, demands, costs, damages, expenses or loss which the City may bear, suffer, incur, become liable for, or be put to by reason of any

damage to property or injury or death to persons by reason of, arising out of or in consequence of breach, violation of non-performance by the successful Proponent of any provision of the agreement, or by reason of or arising out of the use of the premises or in connection with the work covered by this contract, or by reason of or arising out of any act, neglect or default by the successful Proponent or any of its agents or employees or any other person or persons, in, on, or about the premises.

The rights to indemnity contained in this section shall survive any termination of the agreement, anything in this agreement to the contrary notwithstanding.

In addition to the Insurance required for compliance with the requirements of the City's Contractor Pre-Qualification Program, the successful Proponent shall also maintain Professional Liability Insurance as may be required and appropriate for the Project.

In the event of a conflict or inconsistency between Section 1.14 and the Draft Agreement - Appendix A, the Draft Agreement – Appendix A shall prevail.

**1.15 Agreement for Services**

The City Purchase Order issued, the Proposal submitted by the successful Proponent and the RFP as issued and amended including the terms and conditions found in the Draft Agreement as set out in Appendix A shall constitute the Agreement for this Project.



## Appendix A – Draft Agreement

### ENGAGEMENT OF AN INTEGRITY COMMISSIONER FOR THE CITY OF SAULT STE. MARIE

THIS AGREEMENT made in duplicate this [day]<sup>th</sup> day of [month/year].

**B E T W E E N:**

THE CORPORATION OF THE CITY OF SAULT STE. MARIE  
(herein referred to as the "Municipality")

- and -

**[PROPONENT].**  
(herein referred to as the "Integrity Commissioner")

THIS AGREEMENT WITNESSETH THAT in consideration of the mutual promises and obligations contained herein, the Parties agree as follows:

**1. TERM**

This agreement (the "Agreement") shall commence [date] and end [date] (the "Term"), provided that this Agreement is not previously cancelled or terminated by the City in accordance with this Agreement, by operation of law or otherwise, and further provided that the Integrity Commissioner has faithfully complied with and performed all of the covenants and conditions as set out in this Agreement on its part to be performed during the Term.

The Municipality reserves the right to extend the Agreement upon mutual agreement of the Parties hereto and on completion of the Term as set out herein.

**2. DESCRIPTION OF WORK**

The work (the "Work") shall consist of:

- (1) Provide all that is necessary and required to perform all the work shown and described in this Agreement and the Contract Documents, attached as Schedules "A" and "B" to this Agreement.

**3. DOCUMENTS**

- (1) The following list is an exact list of the Contract Documents referred to in Section 2(1) of this Agreement:

- (a) Proposal for Engagement of an Integrity Commissioner for the City of Sault Ste. Marie (the "Proposal"); and
- (b) Request for Proposal – Engagement of an Integrity Commissioner for the City of Sault Ste. Marie (the "RFP").

- (2) In the event of a conflict or inconsistency between the Proposal and the RFP, the RFP shall prevail.

**4. EXECUTION OF WORK**

- (1) The Integrity Commissioner shall always carry out the Work in a diligent manner.

*Appendix A – Draft Agreement Cont'd*

- (2) No information about any account shall be given to any person or entity by the Integrity Commissioner either during or after the Term unless prior written authorization to do so has been provided by the Municipality, and only then, in accordance with the *Municipal Freedom of Information and Protection of Privacy Act*, R.S.O. 1990, c. M.56. Upon expiry of this Agreement, the Integrity Commissioner shall provide to the Municipality all accounts and related documentation pertaining to such accounts.

**5. PAYMENT FOR SERVICES**

- (1) The Integrity Commissioner shall invoice the Municipality monthly for the Work performed for the Municipality at the rates outlined on page 8 of the Proposal and in accordance with the terms outlined thereto.
- (2) Except where a dispute arises with respect to the accuracy of an invoice, the Municipality shall pay to the Integrity Commissioner the invoiced amount within sixty (60) days of receipt thereof.

**6. TERMINATION OF AGREEMENT**

- (1) The Municipality may terminate this Agreement, without cause or reason, by giving the Integrity Commissioner thirty (30) days written notice of its intention to do so.
- (2) Upon termination of this Agreement, the Integrity Commissioner and the Municipality shall forthwith pay to each other any monies owing to date, and the Integrity Commissioner shall return any incomplete account materials.

**7. INSURANCE & INDEMNIFICATION**

- (1) The Integrity Commissioner shall protect itself from and against all claims that might arise from anything done, proposed to be done or omitted to be done by the Integrity Commissioner, its officers, employees, agents or contractors in connection with this Agreement.
- (2) For the purposes of Section 7(1) of this Agreement, and without restricting the generality of that Section, the Integrity Commissioner shall
  - at their expense obtain and keep in force during the term of the Agreement, Commercial General Liability Insurance satisfactory to the (INSERT your Name) and underwritten by an insurer licensed to conduct business in the Province of Ontario. The policy shall provide coverage for Bodily Injury, Property Damage and Personal Injury and shall include but not be limited to:
    - (a) A limit of liability of not less than \$5,000,000 per occurrence with an aggregate of not less than \$5,000,000
    - (b) Add The Corporation of the City of Sault Ste. Marie as an additional insured with respect to the operations of the Named Insured
    - (c) The policy shall contain a provision for cross liability and severability of interest in respect of the Named Insured
    - (d) Non-owned automobile coverage with a limit not less than \$2,000,000 and shall include contractual non-owned coverage (SEF 96)
    - (e) Products and completed operations coverage
    - (f) Contractual Liability

*Appendix A – Draft Agreement Cont’d*

- (g) Work performed on Behalf of the Named Insured by Sub-Contractors
- (h) The policy shall provide 30 days prior notice of cancellation

- take out and keep in force Professional Liability insurance in the amount of \$5,000,000 providing coverage for acts, errors and omissions arising from their professional services performed under this Agreement. The policy SIR/deductible shall not exceed \$25,000 per claim and if the policy has an aggregate limit, the amount of the aggregate shall be double the required per claim limit. The policy shall be underwritten by an insurer licensed to conduct business in the Province of Ontario and acceptable to The Corporation of the City of Sault Ste. Marie. The policy shall be renewed for 3 years after contract termination. A certificate of insurance evidencing renewal is to be provided each and every year. If the policy is to be cancelled or non-renewed for any reason, 90-day notice of said cancellation or non-renewal must be provided to the Risk Manager of The Corporation of the City of Sault Ste. Marie. The Corporation of the City of Sault Ste. Marie has the right to request that an Extended Reporting Endorsement be purchased by the (Professional) at the (Professional's) sole expense.

- (3) The Supplier shall defend, indemnify and save harmless The Corporation of the City of Sault Ste. Marie its elected officials, officers, employees and agents from and against any and all claims of any nature, actions, causes of action, losses, expenses, fines, costs (including legal costs), interest or damages of every nature and kind whatsoever, including but not limited to bodily injury, sickness, disease or death or to damage to or destruction of tangible property including loss of revenue or incurred expense resulting from disruption of service, arising out of or allegedly attributable to the negligence, acts, errors, omissions, misfeasance, nonfeasance, fraud or willful misconduct of the Supplier, its directors, officers, employees, agents, contractors and subcontractors, or any of them, in connection with or in any way related to the delivery or performance of this Contract. This indemnity shall be in addition to and not in lieu of any insurance to be provided by the Supplier in accordance with this Contract and shall survive this Contract.

The Supplier agrees to defend, indemnify and save harmless The Corporation of the City of Sault Ste. Marie from and against any and all claims of any nature, actions, causes of action, losses, expenses, fines, costs (including legal costs), interest or damages of every nature and kind whatsoever arising out of or related to the Supplier's status with WSIB. This indemnity shall be in addition to and not in lieu of any proof of WSIB status and compliance to be provided by the Supplier in accordance with this Contract, and shall survive this Contract.

**8. ASSIGNMENT**

The Integrity Commissioner shall not assign this Agreement or any portion thereof without the prior written consent of the Municipality. In the event that the Municipality consents to such assignment, the Integrity Commissioner shall ensure that any assignee undertaking any of the Integrity Commissioner's obligations hereunder shall be bound by the terms of this Agreement. The Integrity Commissioner shall not be released of its obligation to the Municipality by reason of the assignment, and the Integrity Commissioner shall be deemed liable for any breach of this Agreement, or any legislation or regulation, committed by the assignee.

**9. MUNICIPALITY AND INTEGRITY COMMISSIONER CONTACT PERSONS**

*Appendix A – Draft Agreement Cont’d*

The following contact persons and addresses shall be used by all Parties for all matters in this Agreement that require the Parties to send documentation to a Party, or to contact a Party:

The Corporation of the City of Sault Ste. Marie  
Rachel Tyczinski  
City Clerk  
P.O. Box 580  
Sault Ste. Marie, Ontario P6A 5N1  
Telephone: (705) 759-5391

[Proponent Name]  
[Contact]  
[Address]  
[Phone]

**10. INDEPENDENT CONTRACTOR STATUS**

- (1) The Integrity Commissioner is an independent contractor and neither the Integrity Commissioner nor the Integrity Commissioner's staff is or shall be deemed to be employed by the Municipality. The Integrity Commissioner reserves the right to determine the method, manner and means by which the services will be performed in accordance with Schedules "A" and "B" attached. Notwithstanding the same, the Integrity Commissioner acknowledges and agrees to discharge its obligations and perform the services set out herein in accordance with the terms of this Agreement (including Schedules "A" and "B" attached), the Municipality's Code of Conduct, and all applicable legislation, including but not limited to the *Municipal Act, 2001* and the *Municipal Conflict of Interest Act*.
- (2) The Integrity Commissioner is not required to perform the services during a fixed hourly or daily time and if the services are performed at the Municipality's premises, then the Integrity Commissioner's time spent at the premises is to be at the discretion of the Integrity Commissioner; subject to the Municipality's normal business hours and security requirements. The Integrity Commissioner hereby confirms to the Municipality that the Municipality will not be required to furnish or provide any training to the Integrity Commissioner to enable the Integrity Commissioner to perform services required hereunder.
- (3) The services shall be performed by the Integrity Commissioner or Integrity Commissioner's staff, and the Municipality shall not be required to hire, supervise or pay any assistants to help the Integrity Commissioner who performs the services under this agreement. The Integrity Commissioner shall not be required to devote the Integrity Commissioner's full time nor the full time of the Integrity Commissioner's staff to the performance of the services required hereunder, and it is acknowledged that the Integrity Commissioner has other Clients and the Integrity Commissioner offers services to the general public.
- (4) The order or sequence in which the work is to be performed shall be under the control of the Integrity Commissioner, except to the extent that the Integrity Commissioner's work must be performed on or with the Municipality's computers or the Municipality's existing software. All materials used in providing the services shall be provided by the Integrity Commissioner.
- (5) The Municipality shall not provide any insurance coverage of any kind for the Integrity Commissioner or the Integrity Commissioner's staff, and the Municipality will not withhold any amount that would normally be withheld from an employee's pay.

*Appendix A – Draft Agreement Cont’d*

**11. AMENDMENTS**

The Municipality and the Integrity Commissioner hereby acknowledge and agree that any future amendments to this Agreement must be made in writing and signed by both Parties.

**12. ENTIRE AGREEMENT**

The Integrity Commissioner acknowledges that there are no covenants, representations, warranties, agreements or conditions expressed or implied, collateral or otherwise forming part of or in any way affecting or relating to this Agreement other than as set out in this Agreement and the Contract Documents, which constitutes the entire agreement between the Parties and which may be modified only as set out in Section 11 of this Agreement.

**13. SUCCESSORS**

The provisions of this Agreement shall be binding upon, and ~~enure~~ <sup>enure</sup> to the benefit of, the Parties and their respective successors and, where applicable, permitted assigns.

**14. GOVERNING LAW**

The Parties hereto acknowledge and agree that this Agreement is made in the Province of Ontario and the Courts of the Province of Ontario shall have jurisdiction in reference to any matters herein.

**IN WITNESS WHEREOF** the Parties hereto have signed this Agreement this [day]<sup>th</sup> day of [month/year].

**[PROPONENT]**

Per: \_\_\_\_\_  
Name:  
Position:  
*I have the authority to bind the Corporation*

**THE CORPORATION OF THE CITY OF SAULT STE. MARIE**

Per: \_\_\_\_\_  
MAYOR – MATTHEW SHOEMAKER

Per: \_\_\_\_\_  
CITY CLERK – RACHEL TYCZINSKI

*We have the authority to bind the Corporation*

5

END OF APPENDIX 2

## **SECTION 2**

### **2. TERMS OF REFERENCE**

#### **2.1 Introduction**

The City of Sault Ste. Marie is requesting proposals from qualified proponents who are interested in serving the City as its Integrity Commissioner. The appointment will be on an as needed basis for a five (5) year term, to commence August 1, 2023.

#### **2.2 Background**

The City of Sault Ste. Marie is located in Northern Ontario on the St. Mary's River. The city has approximately 75,000 residents.

Municipal Governance presently consists of a single tier structure with a City Council consisting of a Mayor (Head of Council) and ten (10) Councillors – two for each of the five (5) wards.

#### **2.3 Code of Conduct**

The *Municipal Act* requires municipalities to adopt a Code of Conduct for members of Council and local boards and to appoint an Integrity Commissioner.

The City's Code of Conduct for Council and local boards was adopted by By-law 2017-242 on December 11, 2017 and as Amended by By-law 2019-39 on February 11, 2019, which only amends Appendix "A" and Appendix "B".

A copy of the current Code of Conduct and its associated appendices is attached at the end of this RFP and is labelled as Appendix "1". A review of the Code of Conduct is currently underway.

#### **2.4 Project Scope – Role of the Integrity Commissioner**

The successful Proponent in their role of Integrity Commissioner shall:

- Investigate complaints and alleged breaches of the "Code of Conduct (Council and Elected Boards)" in accordance with the "Complaint Protocol for Code of Conduct (Council and Local Boards) (see Appendix "A" – part of Appendix "1" as attached to this RFP)";
- Review the "Code of Conduct (Council and Elected Boards)" and make recommendations, as required;

## **Request for Proposal**

City of Sault Ste. Marie

Engagement of an Integrity Commissioner

---

- Serve as an advisor to individual Members of City council in relation to the “Code of Conduct (Council and Elected Boards)”, and any procedures, rules and policies of the municipality governing ethical behavior, including under the *Municipal Conflict of Interest Act*;
- Act as a proactive educator for City Council, City staff, and the Public;
- Provide annual Reports to City Council summarizing Integrity Commissioner activities in accordance with section 223.6 of the *Municipal Act, 2001*;
- Provide individual investigative reports, as required, which will include background concerning a complaint and recommendations to City Council with respect to a complaint for its consideration, in accordance with section 223.6 of *the Municipal Act, 2001*;
- Notwithstanding the above, perform the required duties as outlined in the *Municipal Act, 2001* (see Appendix “2” as attached to this RFP).

The Integrity Commissioner will work independently and it is expected that the bulk of the work will be carried out at his/her workplace and not on City property; however, space at a City facility to undertake interviews will be made available, as required.

**The Integrity Commissioner does not have authority over the conduct of City employees.**

### **2.5 Proponent’s Qualifications**

Proponents for appointment to the role of Integrity Commissioner should possess the following qualifications:

- Proven impartiality and neutrality;
- An ability to provide services on a part time, flexible, and as-needed basis;
- No other involvement in political campaigning/endorsement, or related conflicts of interest;
- No financial interest in the work undertaken by the City of Sault Ste. Marie;
- Personifies high ethical standards;
- Experience managing sensitive inquiries, conducting investigations, and making appropriate recommendations;
- Excellent communication skills;
- Familiarity with investigative procedures, and the applicable legal principles;

- Ability to interpret, and apply the provisions of various statutes, regulations, policies, and other enabling frameworks;
- Impartiality, wisdom, sound judgement, combined with the ability to inspire trust, and confidence; and,
- At least ten (10) years of senior-level management, legal, or quasi-judicial experience.

## **2.6 Conflict of Interest**

In addition to complying with any rules as established by a Proponent's governing body, if any, Proponents shall declare any actual or potential conflict of interest that exists now or may exist in the future with respect to the Proponent's participation in this RFP process, and if selected, the performance of the successful Proponent's responsibilities pursuant to the Agreement.

The City reserves the sole right and discretion to determine whether any situation constitutes an actual or potential conflict of interest, and may disqualify any Proponent on that basis.

## **2.7 Experience & Reference**

Demonstrate your professional expertise and qualifications of similar scope services.

- Include relevant past experience on similar projects and professional representative experience, providing relevant references (minimum of 3).
- Proponents qualifications are to be addressed.

## **2.8 Methodology**

Proponents to include details of their Work Plan and Methodology, ensuring quality of work and cost effectiveness, any anticipated assignment of work; setting out proposed response times, and any communication and coordination procedures as appropriate.

Value Add - Outline any additional services which may be beneficial to delivery and completion of the Project.

## **2.9 Fee Schedule**

A comprehensive fee schedule (**HST shown as extra**) detailing the costs associated with the Proponent acting as the City's Integrity Commissioner must be included within the Proposal submitted.



Proponents are encouraged to provide any alternative fee structure as may be available to the City, such as block billing, per diem rates, annual caps on fees etc., in addition to hourly rates.

The Proponent's response shall include:

1. The proposed fee structure and billing methods, including the proposed billing rate for the Proponent and any other pertinent staff members.
2. Any alternative fee structures and proposed disbursement rates.
3. An undertaking that the rates proposed in the fee structure will be guaranteed for the duration of the contract.

All prices must be net and firm.

The Proponent will be solely responsible for any and all payments and/or deductions required, including those required for Canada Pension Plan, Employment Insurance, Workplace Safety and Insurance Board and Income Tax.

Invoicing shall be limited to services actually performed in accordance with the fee schedule proposed.

**SECTION 3**

**3. FORM OF PROPOSAL**  
**ENGAGEMENT OF AN INTEGRITY COMMISSIONER**  
**FOR THE CITY OF SAULT STE. MARIE**

---

Ms. Karen Marlow  
Manager of Purchasing  
Civic Centre, Sault Ste. Marie

I/We the undersigned, hereby submit the attached Proposal to satisfy the requirements laid out by the Corporation of the City of Sault Ste. Marie.

I/We have reviewed and understand the Information to Proponents (Section 1) of the RFP and agree to the terms and conditions contained therein in submitting this Proposal.

I/We agree that this Proposal is made without any connection, knowledge, comparison of figures or arrangements with any other person or persons submitting a Proposal for the same purpose and is in all respects fair and without collusion or fraud.

It is further understood and agreed that the lowest or any Proposal will not necessarily be accepted and that the City reserves the right in its absolute discretion to reject any or all Proposals, or accept the Proposal deemed most acceptable to the City. The City further reserves the right to negotiate with the successful Proponent to finalize the terms and conditions of the Proposal.

I/We acknowledge review of **Addenda #. \_\_\_\_ to #. \_\_\_\_** issued for this Proposal.

This **“Form of Proposal”** must be completed, legibly signed, and returned as part of the Proposal submission to qualify.

\_\_\_\_\_  
NAME OF FIRM

SEAL

\_\_\_\_\_  
ADDRESS

\_\_\_\_\_  
CITY

\_\_\_\_\_  
POSTAL CODE

\_\_\_\_\_  
SIGNING OFFICER SIGNATURE  
I have the authority to bind the Corporation

\_\_\_\_\_  
WITNESS' SIGNATURE (must be present if  
Corporate Seal is not affixed to Form of Proposal)

\_\_\_\_\_  
SIGNING OFFICER'S NAME (please print)

\_\_\_\_\_  
TELEPHONE NUMBER

\_\_\_\_\_  
PRINCIPAL CONTACT EMAIL

\_\_\_\_\_  
DATE

**SECTION 4**

**4. APPENDIXES**

## Appendix 1 - Code of Conduct (Under Review)

Schedule "A"	
	The City of Sault Ste. Marie Information Manual
A-II-11	
<b>Subject:</b>	<b>Code of Conduct (Council and Local Boards)</b>
<b>Service Area:</b>	<b>Mayor and Council</b>
<b>Source:</b>	<b>By-law 2017-242</b>
<b>Date:</b>	<b>11 December 2017</b>
<hr/>	
<b>Purpose:</b>	
<p>A written Code of Conduct for Council and local boards helps to ensure that the members of Council, advisory committees, and local boards of the municipality (as defined in the <i>Municipal Act</i>) share a common basis for acceptable conduct. This Code is designed to provide a reference guide and a supplement to the legislative parameters within which the members must operate. These standards should enhance public confidence that Sault Ste. Marie's elected and appointed representatives operate from a base of integrity, justice and courtesy. The key principles underlining the Code of Conduct are:</p>	
<ul style="list-style-type: none"><li>a. All members shall serve and be seen to serve their constituents in a conscientious and diligent manner;</li><li>b. Members should be committed to performing their functions with integrity and to avoiding the improper use of the influence of their office, and conflicts of interest, both real and apparent;</li><li>c. Members are expected to perform their duties in office in a manner that promotes public confidence and will bear close public scrutiny;</li><li>d. Members shall seek to serve the public interest by upholding both the letter and the spirit of the laws and policies established by the Federal Parliament, Ontario Legislature and City Council.</li></ul>	
<p>Municipal Council members hold positions of privilege; therefore, they must discharge their duties in a manner that recognizes a fundamental commitment to the wellbeing of the community and regard for the integrity of the Corporation. The purpose of the Code of Conduct is to: protect the public interest; encourage high ethical standards among members of Sault Ste. Marie City Council and local boards; provide a universal understanding of the fundamental rights, privileges, and obligations of members of Sault Ste. Marie City Council and local boards; provide a means for members of Sault Ste. Marie City Council and local boards to obtain information on some contemplated conduct in circumstances where they are uncertain as to the ethical appropriateness of that conduct.</p>	
<b>Applications:</b>	
<p>This policy shall apply to all members of Sault Ste. Marie City Council and members of local boards as defined in section 223.1 of the <i>Municipal Act</i>.</p>	
<b>Definitions:</b>	
<p>"Members" includes the Mayor and members of Sault Ste. Marie City Council and members of local boards as defined in section 223.1 of the <i>Municipal Act</i>.</p>	
<p>"Confidential Information" includes:</p>	
<ul style="list-style-type: none"><li>a. Any information in the possession of, or received in confidence by the City, that the City is prohibited from disclosing, or has decided to refuse to disclose, under the <i>Municipal Freedom of Information and Protection of Privacy Act</i> or any other law;</li></ul>	
<hr/>	
Code of Conduct (Council and Local Boards)	Page 1

Appendix 1 – Code of Conduct Cont’d

Schedule "A"	
	The City of Sault Ste. Marie Information Manual
	A-II-11
<p>b. Information of a corporate, commercial, scientific or technical nature received in confidence from third parties (personal information; information that is subject to solicitor-client privilege; information that concerns any confidential matters pertaining to personnel, labour relations, litigation, property acquisition, security of property of the municipality; any other information lawfully determined by the Council or the local board to be confidential or required to remain or be kept confidential by legislation or order;</p> <p>c. A matter, the substance of a matter, and information pertaining to a matter, that has been debated or discussed at a meeting closed to the public, unless the matter is subsequently discussed in open Council or it is authorized to be released by Council/local board or otherwise by law;</p> <p>d. Reports of consultants, draft documents and internal communications which, if disclosed, may prejudice the reputation of the City, its officers and employees, or its effective operation;</p> <p>e. Information concerning litigation, negotiation or personnel matters;</p> <p>f. Information the publication of which may infringe on the rights of any person (eg. source of a complaint where the identity of a complainant is given in confidence)</p> <p>"Integrity Commissioner" means the person appointed by by-law in accordance with section 223.3 of the <i>Municipal Act, 2001</i> and who is responsible for performing in an independent manner the functions assigned by the municipality with respect to the application of the Code of Conduct for members of Council and local boards.</p> <p><b>Gifts and Benefits:</b> No member shall accept a fee, advance, gift or personal benefit that is connected directly or indirectly with the performance of his / her duties of office, unless permitted by the exceptions listed below. For these purposes, a fee or advance paid to, or a gift or benefit provided with the member's knowledge to, a member's spouse, child or parent or to a member's staff that is connected directly or indirectly to the performance of the member's duties is deemed to be a gift to that member. The following are recognized as exceptions:</p> <p>a. compensation authorized by by-law;</p> <p>b. such gifts or benefits that normally accompany the responsibilities of office and are received as an incident of protocol or social obligation;</p> <p>c. a political contribution otherwise reported by law;</p> <p>d. services provided without compensation by persons volunteering their time;</p> <p>e. a suitable memento of a function honouring the member;</p> <p>f. food, lodging, transportation and entertainment provided by provincial, regional and local governments or political subdivisions of them, by the Federal government or by a foreign country;</p> <p>g. food and beverages consumed at banquets, receptions or similar events, if:</p> <ul style="list-style-type: none"><li>o attendance is in keeping with his or her representative role; and</li><li>o the value is reasonable; and</li><li>o attendance at events sponsored by the same entity is infrequent.</li></ul> <p>h. communication to the offices of a member, including subscriptions to newspapers and periodicals.</p>	
Code of Conduct (Council and Local Boards)	
Page 2	

*Appendix 1 – Code of Conduct Cont’d*

	Schedule "A"	A-II-11
<p>The City of Sault Ste. Marie Information Manual</p>		
<p>In the case of categories (b) (e) (f) (g) and (h), if the value of the gift or benefit exceeds \$300, or if the total value received from any one source during the course of a calendar year exceeds \$300, the member shall within 30 days of receipt of the gift or reaching the annual limit, file a disclosure statement with the City Clerk. The disclosure statement must indicate:</p> <ul style="list-style-type: none"><li>a. the nature of the gift or benefit;</li><li>b. its source and date of receipt;</li><li>c. the circumstances under which it was given or received;</li><li>d. its estimated value;</li><li>e. what the recipient intends to do with the gift; and,</li><li>f. whether any gift will at any point be left with the City.</li></ul> <p>Disclosure statements will be a matter of public record.</p> <p>Except in the case of category (f), a member may not accept a gift or benefit worth in excess of \$500 or gifts or benefits from one source during a calendar year worth in excess of \$500. No member shall seek or obtain by reason of his / her office any personal privilege or advantage with respect to City services not otherwise available to the general public and not consequent to his or her official duties.</p> <p><b>Confidentiality</b> No member shall disclose, release, or publish by any means to any person or to the public any confidential information acquired by virtue of his or her office in any form, except when required or authorized by Council or otherwise by law to do so. No member shall use confidential information for personal or private gain or benefit, or for the personal or private gain or benefit of any other person or body.</p> <p><b>Use of City Property</b> No member shall, for personal purposes or profit, permit the use of any City property, equipment, services, or supplies other than for purposes connected with:</p> <ul style="list-style-type: none"><li>a. the discharge of City duties; or</li><li>b. associated community activities of which Council has been advised</li></ul> <p>unless such use is permitted by one of the following exceptions:</p> <ul style="list-style-type: none"><li>a. reasonable and incidental personal use of office space, equipment such as computers, fax machines, cell phones, etc., where the City incurs no additional costs relating to such use, and the use is of limited duration and frequency.</li><li>b. use of City property and facilities where such use is universally known to be available to other residents upon request and on equal terms.</li></ul> <p>No member shall obtain financial gain from the use of City-developed intellectual property, computer programs, technological innovations or other patentable items, while an elected official or thereafter. All such property remains the exclusive property of the City of Sault Ste. Marie.</p> <p>No member shall use information gained in the execution of his or her duties that is not available to the general public for any purposes other than his or her official duties.</p>		
<hr/> <p>Code of Conduct (Council and Local Boards)</p>		<p>Page 3</p>

Appendix 1 – Code of Conduct Cont'd

Schedule "A"	
	A-II-11
The City of Sault Ste. Marie Information Manual	
<p><b>Work of a Political or Personal Nature</b> Members are required to follow the provisions of the <i>Municipal Elections Act, 1996</i>. No member shall use the facilities, equipment, supplies, services or other resources of the City (including Councillor newsletters and websites linked through the City's website) for any election campaign or campaign-related activities. No member shall undertake campaign-related activities in any City facility for the purpose of seeking the support of City employees working in that facility. No member shall use the services of persons for his or her election campaign purposes during the working hours for which those persons receive compensation from the City.</p> <p>No member shall use City facilities, services or property for his or her personal or business use.</p> <p>No member shall use the services of persons for his or her personal or personal business use during the working hours for which those persons receive compensation from the City.</p> <p><b>Conduct Respecting Current and Prospective Employment</b> No member shall allow the prospect of his / her future employment by a person or entity to detrimentally affect the performance of his / her duties to the City.</p> <p><b>Business Relations</b> No member shall act as a paid agent before Council, its committees, or an agency, board or commission of the City. A member shall not refer a third party to a person, partnership, or corporation in exchange for payment or other personal benefit.</p> <p><b>Conduct</b> As a representative of the City, every member has the duty and responsibility to treat members of the public, one another and staff appropriately and without abuse, bullying or intimidation, and to ensure that the municipal work environment is free from discrimination and harassment. A member shall not use indecent, abusive, or insulting words or expressions toward any other member, any member of staff or any member of the public. A member shall not speak or communicate in a manner that is discriminatory to any individual based on that person's race ancestry, place of origin, creed, gender, sexual orientation, age colour, marital status or disability.</p> <p><b>Influence on Staff</b> Only Council as a whole has the authority to approve budget, policy, committee processes and other such matters. Members shall be respectful of the fact that staff work for the City as a body corporate and are charged with making recommendations that reflect their professional expertise and corporate perspective, without undue influence from any individual member or group of members. Accordingly, no member shall maliciously or falsely injure the professional or ethical reputation, or the prospects or practice of staff, and all members shall show respect for the professional capacities of City staff.</p> <p>Council directs the business of the City and passes by-laws or resolutions, as appropriate, for decisions adopted by Council. Council has delegated responsibility to the Chief Administrative Officer (CAO) for the administration of the affairs of the City in accordance with decisions adopted by Council. This means that under the direction of the CAO, staff have the responsibility and the authority to provide</p>	
<hr/>	
Code of Conduct (Council and Local Boards)	Page 4

*Appendix 1 – Code of Conduct Cont’d*

Schedule "A"	
	A-II-11
The City of Sault Ste. Marie Information Manual	
<p>consultation, advice and direction to Council and to implement Council approved policy. Accordingly, staff establish the appropriate administrative policies, systems, structures and internal controls to implement the goals and objectives of Council, and manage implementation within the resources at their disposal. Council should expect a high quality of advice from staff based on political neutrality and objectivity irrespective of party politics, the loyalties of persons in power, or their personal opinions. No member shall compel any staff member to engage in activities that are contrary to the directions of Council or the policies of the municipality.</p> <p>No member shall compel staff to engage in partisan political activities or be subjected to threats or discrimination for refusing to engage in such activities; nor shall any member use, or attempt to use, their authority or influence for the purpose of intimidating, threatening, coercing, commanding, or influencing any staff member with the intent of interfering with that person's duties, including the duty to disclose improper activity.</p> <p><b>Improper Use of Influence</b> No member of Council shall use the influence of her or his office for any purpose other than for the exercise of her or his official duties.</p> <p>Examples of prohibited conduct are the use of one's status as a member of Council to improperly influence the decision of another person to the private advantage of oneself, or one's immediate relatives, staff members, friends, or associates, business or otherwise. This would include attempts to secure preferential treatment beyond activities in which members normally engage on behalf of their constituents as part of their official duties. Also prohibited is the holding out of the prospect or promise of future advantage through a member's supposed influence within Council in return for present actions or inaction.</p> <p>For the purposes of this provision "private advantage" does not include a matter:</p> <ul style="list-style-type: none"><li>a. that is of general application;</li><li>b. that affects a member of Council, his / her immediate relatives, staff members, friends, or associates, business or otherwise as one of a broad class of persons; or</li><li>c. that concerns the remuneration or benefits of a member of Council.</li></ul> <p>Members should not advocate on behalf of any person at a hearing of an adjudicative board and should not contact any member of such a board regarding any application before it.</p> <p><b>Complaints Alleging Violation of This Code</b> Where an elector or a person acting demonstrably in the public interest has reasonable grounds to believe that a member has breached this Code, a complaint may be submitted to the Clerk's Department in the prescribed form which will be forwarded to the City's Integrity Commissioner who will process it in accordance with the Complaint Protocol attached hereto as Appendix "A".</p> <p>Appendix "A" – Complaint Protocol Appendix "B" – Request for Investigation Appendix "C" – Request for Advice</p>	
<hr/>	
Code of Conduct (Council and Local Boards)	Page 5



*Appendix 1 – Code of Conduct Cont'd*

**Appendix "A" (February 11, 2019) (amended by By-law 2019-39)**

**Complaint Protocol for Code of Conduct (Council and Local Boards)**

**Application:**  
This process applies to members of Sault Ste. Marie City Council and its local boards as defined in section 223.1 of the *Municipal Act* (members).

**Integrity Commissioner**  
The City of Sault Ste. Marie Integrity Commissioner shall be responsible for the provision of services as established by Council which will include the following:

1. To provide written and oral advice to members and City staff concerning the interpretation of and compliance with the Code of Conduct for Council and Local Boards governing the ethical behaviour of the members (the "Code");
2. To review the Code of Conduct to ensure it accurately reflects best practice for the conduct of members of Council, local boards, members of City staff or any person demonstrably acting in the public interest and recommending any amendments thereto;
3. To provide Council and its local boards with training regarding the Code of Conduct, the role of the Integrity Commissioner, specific and general opinions and advice on the interpretation of the Code
4. To conduct inquiries or investigations as appropriate, into a request made by Council, a local board, a member of City staff or any person demonstrably acting in the public interest into whether a member has contravened any application provision of the Code;
5. To attempt to settle any complaint between the complainant and the member before commencing an inquiry.

**Procedure for Making a Complaint**

**Informal Complaints**  
Any individual who identifies or witnesses behaviour or activity by a member of Council and its local boards that appears to be in contravention of the Code of Conduct for Council and Local Boards may address the prohibited behaviour or activity themselves in the following manner:

1. advise the member in writing that the behaviour or activity appears to contravene the Code of Conduct identifying the specific provision of the Code of Conduct that is alleged to have been contravened;
2. encourage the member to acknowledge and agree to stop the prohibited behaviour or activity and to avoid future occurrences of the prohibited behaviour or activity;
3. document the incident(s) including dates, times, locations, other persons present and any other relevant information, including steps taken to resolve the matter;
4. if applicable, confirm to the member satisfaction with the response of the member; or, if applicable, advise the member of dissatisfaction with the response; and
5. if applicable, consider the need to pursue the matter in accordance with the formal complaint procedure.

Individuals are encouraged to pursue this informal complaint procedure as the first means of remedying behaviour or an activity that they believe violates the Code of Conduct; however, the informal process is not a precondition or a prerequisite to pursuing the formal complaint procedure.

**Formal Complaints**

1. All complaints or requests for inquiries shall be submitted to the City Clerk's Department and sworn before a commissioner of oaths in the form provided in Appendix "B" and the Clerk shall forthwith forward the complaint to the Integrity Commissioner.
2. All complaints or requests for inquiries must clearly state:
  - a. The member to whom the complaint relates
  - b. The nature of the alleged contravention
  - c. The specific provision(s) of the Code allegedly contravened;
  - d. Names of any witnesses to the alleged contravention; and
  - e. Written material in support of the alleged contravention.

*Appendix 1 – Code of Conduct Cont’d*

3. All complaints or requests for inquiries must be accompanied by all written materials (documents or records), considered to be relevant to the complaint or requests for inquiry.
4. Upon receipt of a complaint or request for inquiry, the Integrity Commissioner shall first determine if it is within his/her jurisdiction and whether there is a procedure under other legislation or City policy to deal with the complaint. If it is determined that other procedures apply, the Integrity Commissioner shall refer the complainant to the appropriate person or agency to follow that process. This would include such matters as:
  - a. The complaint provisions under the *Ontario Human Rights Code*;
  - b. A complaint of alleged criminal activity;
  - c. Procedures under the *Municipal Act*, the *Municipal Conflict of Interest Act* or the *Municipal Elections Act*;
  - d. The complaint provisions of the *Workplace Violence and Harassment Prevention Policy*, as stated in that policy.Where it has been determined that a complaint should be dealt with under one of the above processes, it will no longer be considered or dealt with by the Integrity Commissioner and the time limits within the above processes will apply accordingly.
5. Upon receipt of a complaint or request to conduct an inquiry within his/her jurisdiction the Integrity Commissioner will deliver a preliminary information report to an open meeting of Council including the following:
  - a. The opinion of the Commissioner as to whether the inquiry is appropriate and whether it can be conducted within the law applicable to such an inquiry;
  - b. An indication as to whether it is the Commissioner’s intention to conduct the inquiry under sections 33 and 34 of the *Public Inquiries Act*;
  - c. A preliminary indication of the members of staff and/or consultations needed to assist the Commissioner;
  - d. An estimated cost of the inquiry;
  - e. The estimated time required to complete the inquiry and prepare a final report;
  - f. Where appropriate, the Commissioner may recommend that the alleged infraction be reported to the police and that the inquiry be suspended until the police investigation is completed.
6. If the Integrity Commissioner is of the opinion that the referral of a matter to him or her is frivolous, vexatious or not made in good faith or that there are no grounds or insufficient grounds for an inquiry, the Integrity Commissioner shall not conduct an inquiry and shall state the reasons for not doing so in the preliminary report.

**Procedure for Obtaining Advice**

Where a member or employee is seeking to obtain advice from the Integrity Commissioner, he/she shall submit to the City Clerk the completed form provided (Appendix “C”).

All advice of the Integrity Commissioner to members or employees shall be confirmed in writing. No solicitor/client relationship will exist in the giving of such advice.

Where the Integrity Commissioner learns of a violation through the request for advice from any member, he or she is required to report such a violation to Council.

The Integrity Commissioner may decline to give advice if he/she determines that it will put him/her in conflict with his/her duty to Council as a whole.

**Confidentiality**

The Integrity Commissioner shall carry out all inquiries in a manner which will ensure that the individual to whom the complaint relates is treated fairly and all complaints shall be treated as confidential to the extent possible and in accordance with the *Municipal Act*.

All records of investigations shall be kept confidential and access limited to those in the City with a need to know for the purposes of conducting a full investigation.

*Appendix 1 – Code of Conduct Cont’d*

**Intake Procedures**

Upon receipt of a complaint involving a member other than the Mayor, the Clerk shall immediately advise the Mayor and the Chief Administrative Officer (CAO).

Upon receipt of a complaint involving the Mayor, the Clerk shall immediately advise the CAO and the individual who was acting mayor at the time of the allegation who is authorized to act in the place of the Mayor.

The Integrity Commissioner may attempt to settle any complaint. Except where otherwise required by the *Public Inquiries Act*, the Commissioner shall provide a copy of the complaint and supporting material to the member with a request for a written response to the allegation within ten days and provide a copy of such response to the complainant with a request for a written response also within ten days.

**Investigations**

After the presentation of the information report to Council, the Integrity Commissioner shall take all steps necessary to promptly investigate the complaint within his or her jurisdiction, including entering any City office for such purpose and consultation with City staff with access to all information and records described in subsections 3 and 4 of section 223.4 of the *Municipal Act* and may retain independent professional services if required.

The Integrity Commissioner shall make every effort to complete an investigation within 30 days.

If the Integrity Commissioner requires more than 30 days to complete an investigation, the following shall be notified accordingly:

1. The complainant;
2. The individual to whom the complaint relates
3. The Mayor in the case of a complaint concerning another member; or the individual who was acting mayor at the time of the allegation in the case of a complaint concerning the Mayor.

A complaint involving an alleged contravention that has already been thoroughly investigated will not be re-investigated unless new evidence is presented.

**Reporting the Results of an Investigation**

The Integrity Commissioner shall report his/her findings to an open meeting of Council. Where the inquiry relates to a local board the report will be submitted both to Council and to the local board.

If the Integrity Commissioner determines that there has been no contravention of the Code of Conduct or that a contravention occurred although the member took all reasonable measures to prevent it, or that a contravention occurred that was trivial or committed through inadvertence or an error of judgement made in good faith, the Integrity Commissioner shall so state in the report and shall recommend that no penalty be imposed.

The Commissioner shall give a copy of the final report to the complainant and the member whose conduct is concerned 15 days prior to the Council meeting at which it will be considered.

At the time of the Integrity Commissioner’s report to Council the identity of the person who is the subject of the complaint shall not be treated as confidential information if the Integrity Commissioner finds that a breach has occurred.

**Actions by Council**

In reviewing the final report Council will determine whether it will impose any of the following penalties on a member if the Integrity Commissioner reports that it is his/her opinion that the member has contravened the Code:

1. Issue a motion of reprimand;
2. Suspension of the remuneration paid to the member in respect of his or her services as a member for a period of up to 90 days;
3. Request the member involved to return any gift or benefit received in contravention of the Code of Conduct;
4. Request the member involved the repay the value of the benefit;
5. Remove the member from committee or local board appointments;
6. Request an apology; or
7. Withhold confidential materials/matters for a period of time.

*Appendix 1 – Code of Conduct Cont’d*

All reports to Council by the Integrity Commissioner on the investigation of complaints are public documents.

The Integrity Commissioner shall be responsible for ensuring the above procedures are followed with respect to requests for inquiries and for conducting investigations. City Council shall be responsible for determining penalties where appropriate.

**Protection from Retaliation**

Any employee who files a complaint of a contravention of the Code of Conduct will not be subjected to any form of penalty or reprisal provided the complaint is made in good faith and in the reasonable belief of the complainant that a contravention of the Code has occurred.

**Limitation Period**

The Integrity Commissioner shall not proceed with an inquiry in regard to a complaint more than 60 days after the event or series of events which are the subject matter of the complaint were discovered by the complainant. An event or series of events is discovered on the earlier of the date upon which the complainant first knew:

- that the event(s) had occurred and by whom; and
- that the event(s) may have constituted a contravention of the Code.

The onus of proof as to the date of discovery lies with the complainant.

Where the Integrity Commissioner decides not to proceed with an investigation of a complaint received more than 60 days after the date when the event(s) occurred, the Integrity Commissioner shall prepare and file a report setting out that decision.

**Complaints in Municipal Election Years**

Despite any other provision of this process, if the Commissioner has not completed an inquiry before nomination day for a regular election as set out in section 31 of the *Municipal Elections Act, 1996*, the Commissioner shall terminate the inquiry on that day.

If an inquiry is so terminated, the Commissioner shall not commence another inquiry in respect of the matter unless, within six weeks after voting day in a regular election, as set out in section 5 of the *Municipal Elections Act, 1996*, the person or entity who made the request or the member or former member whose conduct is concerned makes a written request to the Commissioner that the inquiry be commenced.

The following rules apply during the period of time starting on nomination day for a regular election, as set out in section 31 of the *Municipal Elections Act, 1996*, and ending on voting day in a regular election, as set out in section 5 of that Act:

1. There shall be no requests for an inquiry about whether a member of council or of a local board has contravened the code of conduct applicable to the member.
2. The Commissioner shall not report to the municipality or local board about whether, in his or her opinion, a member of council or of a local board has contravened the code of conduct applicable to the member.
3. The municipality or local board shall not consider whether to impose the penalties referred to in subsection (5) on a member of council or of a local board.

*Appendix 1 – Code of Conduct Cont’d*

<b>Appendix "B" (February 11, 2019)</b>		<b>Amended by By-law 2019-39</b>	
<b>Request for Investigation</b>			
<b>Code of Conduct for Members of Council and Local Boards</b>			
Name of Requestor:			
Address:			
Telephone:			
Email address:			
It is an offence under the Criminal Code of Canada to knowingly swear/affirm a false affidavit.			
I,		<i>(full name)</i>	
of		<i>(municipality of residence)</i>	
in the Province of Ontario, MAKE OATH AND SAY (or affirm)			
1. I have personal knowledge of the facts as set out in this affidavit.			
2. I have reasonable and probable grounds to believe that:			
<i>(specify name of member of Sault Ste. Marie City Council or local board)</i>			
has contravened section(s)		<i>(specify)</i>	
of the Code of Conduct for Members of Council and Local Boards.			
Date of Incident:			
Time of Incident:			
Location of Incident:			
Name(s), Position, Contact Information (phone number or email address) of all Witnesses to the Incident:			
a)			
b)			
c)			
d)			
3. This affidavit is made for the purpose of requesting that this matter be investigated and for no improper purpose.			
List of documents or records that are relevant to the requested inquiry. <i>(include document title and date)</i>			
<b>ALL DOCUMENTS OR RECORDS CONSIDERED RELEVANT TO THE COMPLAINT OR REQUEST FOR INQUIRY MUST ACCOMPANY THIS REQUEST FOR INVESTIGATION FORM</b>			
SWORN (or affirmed) before me at the City of Sault Ste Marie, in the District of Algoma, this      day of              20		Requestor's signature	
A Commissioner, etc.			
Deliver request to: City Clerk's Department, Civic Centre, 99 Foster Drive, Sault Ste. Marie ON P6A 5X6			





## Appendix 2 – Municipal Act, 2001

*Excerpt from the Municipal Act, 2001, SO 2001, c25, s 223.3 to s223.8 Sections outlining the role of Integrity Commissioner*

### **Integrity Commissioner**

**223.3 (1)** Without limiting sections 9, 10 and 11, those sections authorize the municipality to appoint an Integrity Commissioner who reports to council and who is responsible for performing in an independent manner the functions assigned by the municipality with respect to any or all of the following:

1. The application of the code of conduct for members of council and the code of conduct for members of local boards.
2. The application of any procedures, rules and policies of the municipality and local boards governing the ethical behaviour of members of council and of local boards.
3. The application of sections 5, 5.1, 5.2 and 5.3 of the *Municipal Conflict of Interest Act* to members of council and of local boards.
4. Requests from members of council and of local boards for advice respecting their obligations under the code of conduct applicable to the member.
5. Requests from members of council and of local boards for advice respecting their obligations under a procedure, rule or policy of the municipality or of the local board, as the case may be, governing the ethical behaviour of members.
6. Requests from members of council and of local boards for advice respecting their obligations under the *Municipal Conflict of Interest Act*.
7. The provision of educational information to members of council, members of local boards, the municipality and the public about the municipality's codes of conduct for members of council and members of local boards and about the *Municipal Conflict of Interest Act*. 2017, c. 10, Sched. 1, s. 19 (1); 2022, c. 24, Sched. 3, s. 3.

### **Provision for functions if no Commissioner appointed**

(1.1) If a municipality has not appointed a Commissioner under subsection (1), the municipality shall make arrangements for all of the responsibilities set out in that subsection to be provided by a Commissioner of another municipality. 2017, c. 10, Sched. 1, s. 19 (2).

### **Provision for functions if responsibility not assigned**

(1.2) If a municipality has appointed a Commissioner under subsection (1), but has not assigned functions to the Commissioner with respect to one or more of the responsibilities set out in that subsection, the municipality shall make arrangements for those responsibilities to be provided by a Commissioner of another municipality. 2017, c. 10, Sched. 1, s. 19 (2).

### **Powers and duties**

(2) Subject to this Part, in carrying out the responsibilities described in subsection (1), the Commissioner may exercise such powers and shall perform such duties as may be assigned to him or her by the municipality. 2006, c. 32, Sched. A, s. 98.

### **Request for advice shall be in writing**

(2.1) A request by a member of council or of a local board for advice from the Commissioner under paragraph 4, 5 or 6 of subsection (1) shall be made in writing. 2017, c. 10, Sched. 1, s. 19 (3).

### **Advice shall be in writing**



*Appendix 2 – Municipal Act, 2001 Cont'd*

(2.2) If the Commissioner provides advice to a member of council or of a local board under paragraph 4, 5 or 6 of subsection (1), the advice shall be in writing. 2017, c. 10, Sched. 1, s. 19 (3).

**Content of educational information**

(2.3) If the Commissioner provides educational information to the public under paragraph 7 of subsection (1), the Commissioner may summarize advice he or she has provided but shall not disclose confidential information that could identify a person concerned. 2017, c. 10, Sched. 1, s. 19 (3).

**Delegation**

(3) The Commissioner may delegate in writing to any person, other than a member of council, any of the Commissioner's powers and duties under this Part. 2006, c. 32, Sched. A, s. 98.

**Same**

(4) The Commissioner may continue to exercise the delegated powers and duties, despite the delegation. 2006, c. 32, Sched. A, s. 98.

**Status**

(5) The Commissioner is not required to be a municipal employee. 2006, c. 32, Sched. A, s. 98.

**Indemnity**

(6) A municipality shall indemnify and save harmless the Commissioner or any person acting under the instructions of that officer for costs reasonably incurred by either of them in connection with the defence of a proceeding if the proceeding relates to an act done in good faith in the performance or intended performance of a duty or authority under this Part or a by-law passed under it or an alleged neglect or default in the performance in good faith of the duty or authority. 2017, c. 10, Sched. 1, s. 19 (4).

**Interpretation**

(7) For greater certainty, nothing in this section affects the application of section 448 with respect to a proceeding referred to in subsection (6) of this section. 2017, c. 10, Sched. 1, s. 19 (4).

**Section Amendments with date in force (d/m/y)**

**Inquiry by Commissioner**

**223.4** (1) This section applies if the Commissioner conducts an inquiry under this Part,  
(a) in respect of a request made by council, a member of council or a member of the public about whether a member of council or of a local board has contravened the code of conduct applicable to the member; or  
(b) in respect of a request made by a local board or a member of a local board about whether a member of the local board has contravened the code of conduct applicable to the member. 2006, c. 32, Sched. A, s. 98.

**Powers on inquiry**

(2) The Commissioner may elect to exercise the powers under sections 33 and 34 of the *Public Inquiries Act, 2009*, in which case those sections apply to the inquiry. 2009, c. 33, Sched. 6, s. 72 (1).

**Information**

(3) The municipality and its local boards shall give the Commissioner such information as the Commissioner believes to be necessary for an inquiry. 2006, c. 32, Sched. A, s. 98.

**Same**

(4) The Commissioner is entitled to have free access to all books, accounts, financial records, electronic data processing records, reports, files and all other papers, things or

*Appendix 2 – Municipal Act, 2001 Cont'd*

property belonging to or used by the municipality or a local board that the Commissioner believes to be necessary for an inquiry. 2006, c. 32, Sched. A, s. 98.

**Penalties**

(5) The municipality may impose either of the following penalties on a member of council or of a local board if the Commissioner reports to the municipality that, in his or her opinion, the member has contravened the code of conduct:

1. A reprimand.
2. Suspension of the remuneration paid to the member in respect of his or her services as a member of council or of the local board, as the case may be, for a period of up to 90 days. 2006, c. 32, Sched. A, s. 98.

**Same**

(6) The local board may impose either of the penalties described in subsection (5) on its member if the Commissioner reports to the board that, in his or her opinion, the member has contravened the code of conduct, and if the municipality has not imposed a penalty on the member under subsection (5) in respect of the same contravention. 2006, c. 32, Sched. A, s. 98.

**Termination of inquiry when regular election begins**

(7) If the Commissioner has not completed an inquiry before nomination day for a regular election, as set out in section 31 of the Municipal Elections Act, 1996, the Commissioner shall terminate the inquiry on that day. 2017, c. 10, Sched. 1, s. 20.

**Same**

(8) If an inquiry is terminated under subsection (7), the Commissioner shall not commence another inquiry in respect of the matter unless, within six weeks after voting day in a regular election, as set out in section 5 of the Municipal Elections Act, 1996, the person or entity who made the request or the member or former member whose conduct is concerned makes a written request to the Commissioner that the inquiry be commenced. 2017, c. 10, Sched. 1, s. 20.

**Other rules that apply during regular election**

(9) The following rules apply during the period of time starting on nomination day for a regular election, as set out in section 31 of the Municipal Elections Act, 1996, and ending on voting day in a regular election, as set out in section 5 of that Act:

1. There shall be no requests for an inquiry about whether a member of council or of a local board has contravened the code of conduct applicable to the member.
2. The Commissioner shall not report to the municipality or local board about whether, in his or her opinion, a member of council or of a local board has contravened the code of conduct applicable to the member.
3. The municipality or local board shall not consider whether to impose the penalties referred to in subsection (5) on a member of council or of a local board. 2017, c. 10, Sched. 1, s. 20.

**Section Amendments with date in force (d/m/y)**

**Inquiry by Commissioner re s. 5, 5.1, 5.2 or 5.3 of *Municipal Conflict of Interest Act***

**223.4.1** (1) This section applies if the Commissioner conducts an inquiry under this Part in respect of an application under subsection (2). 2017, c. 10, Sched. 1, s. 21.

**Application**

(2) An elector, as defined in section 1 of the *Municipal Conflict of Interest Act*, or a person demonstrably acting in the public interest may apply in writing to the Commissioner for an inquiry to be carried out concerning an alleged contravention of section 5, 5.1, 5.2 or 5.3

*Appendix 2 – Municipal Act, 2001 Cont'd*

of that Act by a member of council or a member of a local board. 2017, c. 10, Sched. 1, s. 21; 2022, c. 24, Sched. 3, s. 4.

**No application for inquiry during regular election**

(3) No application for an inquiry under this section shall be made to the Commissioner during the period of time starting on nomination day for a regular election, as set out in section 31 of the *Municipal Elections Act, 1996*, and ending on voting day in a regular election, as set out in section 5 of that Act. 2017, c. 10, Sched. 1, s. 21.

**Timing**

(4) An application may only be made within six weeks after the applicant became aware of the alleged contravention. 2017, c. 10, Sched. 1, s. 21.

**Exception**

(5) Despite subsection (4), an application may be made more than six weeks after the applicant became aware of the alleged contravention if both of the following are satisfied:

1. The applicant became aware of the alleged contravention within the period of time starting six weeks before nomination day for a regular election, as set out in section 31 of the *Municipal Elections Act, 1996*, and ending on voting day in a regular election, as set out in section 5 of that Act.
2. The applicant applies to the Commissioner under subsection (2) within six weeks after the day after voting day in a regular election, as set out in section 5 of the *Municipal Elections Act, 1996*. 2017, c. 10, Sched. 1, s. 21.

**Content of application**

(6) An application shall set out the reasons for believing that the member has contravened section 5, 5.1, 5.2 or 5.3 of the *Municipal Conflict of Interest Act* and include a statutory declaration attesting to the fact that the applicant became aware of the contravention not more than six weeks before the date of the application or, in the case where an applicant became aware of the alleged contravention during the period of time described in paragraph 1 of subsection (5), a statutory declaration attesting to the fact that the applicant became aware of the alleged contravention during that period of time. 2017, c. 10, Sched. 1, s. 21; 2022, c. 24, Sched. 3, s. 4.

**Inquiry**

(7) The Commissioner may conduct such inquiry as he or she considers necessary. 2017, c. 10, Sched. 1, s. 21.

**Public meeting**

(8) If the Commissioner decides to conduct an inquiry, the Commissioner may have a public meeting to discuss the inquiry. 2017, c. 10, Sched. 1, s. 21.

**Powers on inquiry**

(9) The Commissioner may elect to exercise the powers under sections 33 and 34 of the *Public Inquiries Act, 2009*, in which case those sections apply to the inquiry. 2017, c. 10, Sched. 1, s. 21.

**Information**

(10) The municipality and its local boards shall give the Commissioner such information as the Commissioner believes to be necessary for an inquiry. 2017, c. 10, Sched. 1, s. 21.

**Same**

(11) The Commissioner is entitled to have free access to all books, accounts, financial records, electronic data processing records, reports, files and all other papers, things or property belonging to or used by the municipality or a local board that the Commissioner believes to be necessary for an inquiry. 2017, c. 10, Sched. 1, s. 21.

*Appendix 2 – Municipal Act, 2001 Cont'd*

<p><b>Termination of inquiry when regular election begins</b> (12) If the Commissioner has not completed an inquiry before nomination day for a regular election, as set out in section 31 of the <i>Municipal Elections Act, 1996</i>, the Commissioner shall terminate the inquiry on that day. 2017, c. 10, Sched. 1, s. 21.</p> <p><b>Same</b> (13) If an inquiry is terminated under subsection (12), the Commissioner shall not commence another inquiry in respect of the matter unless, within six weeks after voting day in a regular election, as set out in section 5 of the <i>Municipal Elections Act, 1996</i>, the person who made the application or the member or former member whose conduct is concerned applies in writing to the Commissioner for the inquiry to be carried out. 2017, c. 10, Sched. 1, s. 21.</p> <p><b>Timing</b> (14) The Commissioner shall complete the inquiry within 180 days after receiving the completed application, unless the inquiry is terminated under subsection (12). 2017, c. 10, Sched. 1, s. 21.</p> <p><b>Completion</b> (15) Upon completion of the inquiry, the Commissioner may, if he or she considers it appropriate, apply to a judge under section 8 of the <i>Municipal Conflict of Interest Act</i> for a determination as to whether the member has contravened section 5, 5.1, 5.2 or 5.3 of that Act. 2017, c. 10, Sched. 1, s. 21; 2022, c. 24, Sched. 3, s. 4.</p> <p><b>Notice to applicant re decision not to apply to judge</b> (16) The Commissioner shall advise the applicant if the Commissioner will not be making an application to a judge. 2017, c. 10, Sched. 1, s. 21.</p> <p><b>Reasons after inquiry</b> (17) After deciding whether or not to apply to a judge, the Commissioner shall publish written reasons for the decision. 2017, c. 10, Sched. 1, s. 21.</p> <p><b>Costs</b> (18) The Commissioner's costs of applying to a judge shall be paid by the following: 1. If the member is alleged to have contravened section 5, 5.1, 5.2 or 5.3 of the <i>Municipal Conflict of Interest Act</i> as a member of council of a municipality, the municipality. 2. If the member is alleged to have contravened section 5, 5.1, 5.2 or 5.3 of the <i>Municipal Conflict of Interest Act</i> as a member of a local board, the local board. 2017, c. 10, Sched. 1, s. 21; 2022, c. 24, Sched. 3, s. 4.</p> <p><b>Section Amendments with date in force (d/m/y)</b></p> <p><b>Duty of confidentiality</b> 223.5 (1) The Commissioner and every person acting under the instructions of the Commissioner shall preserve secrecy with respect to all matters that come to his or her knowledge in the course of his or her duties under this Part. 2006, c. 32, Sched. A, s. 98.</p> <p><b>Exception</b> (2) Despite subsection (1), information may be disclosed in a criminal proceeding as required by law or otherwise in accordance with this Part. 2006, c. 32, Sched. A, s. 98.</p> <p><b>Release of advice</b> (2.1) Advice provided by the Commissioner to a member under paragraph 4, 5 or 6 of subsection 223.3 (1) may be released with the member's written consent. 2017, c. 10, Sched. 1, s. 22.</p> <p><b>Partial release by member</b></p>
--

*Appendix 2 – Municipal Act, 2001 Cont'd*

(2.2) If a member releases only part of the advice provided to the member by the Commissioner under paragraph 4, 5 or 6 of subsection 223.3 (1), the Commissioner may release part or all of the advice without obtaining the member's consent. 2017, c. 10, Sched. 1, s. 22.

**Other circumstances**

(2.3) The Commissioner may disclose such information as in the Commissioner's opinion is necessary,

- (a) for the purposes of a public meeting under subsection 223.4.1 (8);
  - (b) in an application to a judge referred to in subsection 223.4.1 (15); or
  - (c) in the written reasons given by the Commissioner under subsection 223.4.1 (17).
- 2017, c. 10, Sched. 1, s. 22.

**Section prevails**

(3) This section prevails over the *Municipal Freedom of Information and Protection of Privacy Act*. 2006, c. 32, Sched. A, s. 98.

**Section Amendments with date in force (d/m/y)**

**Report to council**

223.6 (1) If the Commissioner provides a periodic report to the municipality on his or her activities, the Commissioner may summarize advice he or she has given but shall not disclose confidential information that could identify a person concerned. 2006, c. 32, Sched. A, s. 98.

**Report about conduct**

(2) If the Commissioner reports to the municipality or to a local board his or her opinion about whether a member of council or of the local board has contravened the applicable code of conduct, the Commissioner may disclose in the report such matters as in the Commissioner's opinion are necessary for the purposes of the report. 2006, c. 32, Sched. A, s. 98.

**Publication of reports**

(3) The municipality and each local board shall ensure that reports received from the Commissioner by the municipality or by the board, as the case may be, are made available to the public. 2006, c. 32, Sched. A, s. 98.

**Section Amendments with date in force (d/m/y)**

**Testimony**

223.7 Neither the Commissioner nor any person acting under the instructions of the Commissioner is a competent or compellable witness in a civil proceeding in connection with anything done under this Part. 2006, c. 32, Sched. A, s. 98.

**Section Amendments with date in force (d/m/y)**

**Reference to appropriate authorities**

223.8 If the Commissioner, when conducting an inquiry, determines that there are reasonable grounds to believe that there has been a contravention of any other Act, other than the *Municipal Conflict of Interest Act*, or of the *Criminal Code* (Canada), the Commissioner shall immediately refer the matter to the appropriate authorities and suspend the inquiry until any resulting police investigation and charge have been finally disposed of, and shall report the suspension to council. 2006, c. 32, Sched. A, s. 98; 2017, c. 10, Sched. 1, s. 23.

**THE CORPORATION OF THE CITY OF SAULT STE. MARIE**

**BY-LAW 2023-96**

**VENDORS PROHIBITED:** A by-law to prohibit vendors from locating on or near the grounds of Rotaryfest 2023.

**THE COUNCIL** of The Corporation of the City of Sault Ste. Marie, pursuant to section 10 of the *Municipal Act, 2001*, S.O. 2001, c. 25, **ENACTS** as follows:

1. **VENDORS PROHIBITED**

Without the prior written permission of Rotary Club of Sault Ste. Marie and despite the provisions of By-laws 3306 and 84-196, during July 8<sup>th</sup> to July 16<sup>th</sup>, 2023 inclusive, vendors licensed under those by-laws shall not locate on or near the grounds of Rotaryfest 2023 more particularly described on Schedule "A" to this by-law:

- (a) Russ Ramsay Way south of the entrance to the Senior Drop In Centre;
- (b) Foster Drive from Russ Ramsay Way to the east entrance to the south Civic Centre parking lot;
- (c) South side of Bay Street between Brock and East Streets including the sidewalk;
- (d) Lower East Street south of Bay Street and Ken Danby Way; and
- (e) The Senior Drop In Centre parking lot off of Foster Drive.

2. **PENALTY**

Every person who contravenes any provision of this by-law is guilty of an offence and on conviction is liable to a fine as provided for in the Provincial Offences Act.

3. **SCHEDULE "A"**

Schedule "A" hereto forms part of this by-law.

4. **EFFECTIVE DATE**

This by-law is effective on the final date of its passing.

**PASSED** in open Council this 19<sup>th</sup> day of June, 2023.

---

**MAYOR – MATTHEW SHOEMAKER**

---

**CITY CLERK – RACHEL TYCZINSKI**

Schedule "A"

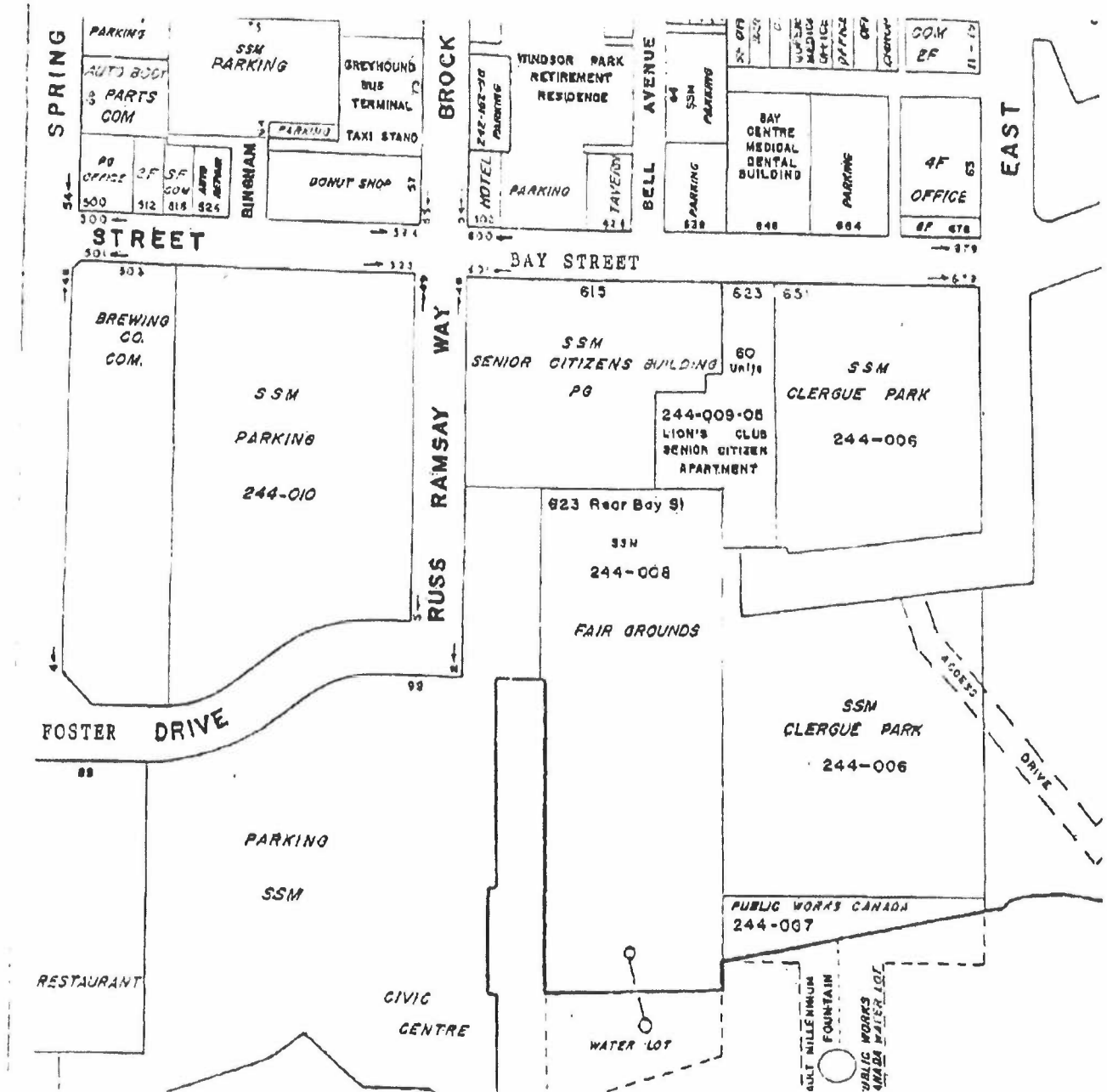

**THE CORPORATION OF THE CITY OF SAULT STE. MARIE**

**BY-LAW 2023-97**

**APPOINTMENTS:** A by-law to appoint Naomi Thibault as Deputy Fire Chief Fire Prevention, Public Education and Emergency Management.

**WHEREAS** the *Fire Protection and Prevention Act*, 1997, S.O. 1997, c.4, as amended, permits a municipality to establish, maintain and operate a fire department;

**NOW THEREFORE THE COUNCIL** of The Corporation of the City of Sault Ste. Marie **ENACTS** as follows:

1. **APPOINTMENT – DEPUTY FIRE CHIEF FIRE PREVENTION, PUBLIC EDUCATION AND EMERGENCY MANAGEMENT**

Naomi Thibault is hereby appointed as Deputy Fire Chief Fire Prevention, Public Education and Emergency Management commencing May 1, 2023.

2. **BY-LAW 2018-139 REPEALED**

By-law 2018-139 is hereby repealed.

3. **EFFECTIVE DATE**

This by-law is effective on May 1, 2023.

**PASSED** in open Council this 19<sup>th</sup> day of June, 2023.

---

**MAYOR – MATTHEW SHOEMAKER**

---

**CITY CLERK – RACHEL TYCZINSKI**

da LEGAL\STAFF\COUNCIL\BY-LAWS\2023\2023-97 - APPOINTMENT OF NAOMI THIBAUT AS DEPUTY FIRE CHIEF FIRE PREVENTION, PUBLIC EDUCATION AND EMERGENCY MANAGEMENT.DOCX



**THE CORPORATION OF THE CITY OF SAULT STE. MARIE**

**BY-LAW 2023-98**

**APPOINTMENTS:** A by-law to appoint Paul Antonello, Dave Kochanowski, Gary Schryer and Craig Genys as Fire Prevention Officers for the purpose of enforcing By-law 81-404 and By-law 2009-82.

**WHEREAS** the *Fire Protection and Prevention Act*, Part 2 (1)(a) provides that every municipality shall establish a program in the municipality which must include public education with respect to the fire safety and certain components of fire prevention;

**WHEREAS** the *Fire Protection and Prevention Act*, Part 2 (1)(b) provides that every municipality shall provide such other fire protection services as it determines may be necessary in accordance with its needs and circumstances;

**WHEREAS** the *Fire Protection and Prevention Act*, Part 2 (2) provides that in discharging its responsibilities under subsection (1), a municipality shall under subsection (1)(a) appoint a community fire safety officer or a community fire safety team;

**AND WHEREAS** the Council of the Corporation of the City of Sault Ste. Marie deems it desirable and expedient to appoint Fire Prevention Officers.

**NOW THEREFORE THE COUNCIL** of The Corporation of the City of Sault Ste. Marie **ENACTS** as follows:

1. **APPOINTMENT – FIRE PREVENTION OFFICERS**

The following Fire Prevention Officers are hereby appointed for the purpose of enforcing By-law 81-404 and By-law 2009-82:

Paul Antonello appointed January 6, 2003;  
Dave Kochanowski appointed March 8, 2021;  
Gary Schryer appointed May 29, 2023; and  
Craig Genys appointed May 16, 2022.

2. **BY-LAW 2022-110 REPEALED**

By-law 2022-110 is hereby repealed.

**PASSED** in open Council this 19<sup>th</sup> day of June, 2023.

---

**MAYOR – MATTHEW SHOEMAKER**

---

**CITY CLERK – RACHEL TYCZINSKI**

**THE CORPORATION OF THE CITY OF SAULT STE. MARIE**

**BY-LAW 2023-99**

**ENGINEERING**: A by-law to authorize the execution of the AECOM Canada Ltd. fee addendum for non-core municipal infrastructure assets.

**THE COUNCIL** of The Corporation of the City of Sault Ste. Marie, pursuant to section 9 of the *Municipal Act, 2001*, S.O. 2001, c. 25, **ENACTS** as follows:

1. **EXECUTION OF DOCUMENT**

The Mayor and City Clerk are hereby authorized for and in the name of the Corporation to execute and affix the seal of the Corporation to the AECOM Canada Ltd. fee addendum to the Agreement dated August 9, 2021 between the City and AECOM Canada Ltd., a copy of which is attached as Schedule "A" hereto. This fee addendum is for non-core municipal infrastructure assets.

2. **SCHEDULE "A"**

Schedule "A" forms part of this by-law.

3. **EFFECTIVE DATE**

This by-law takes effect on the day of its final passing.

**PASSED** in open Council this 19<sup>th</sup> day of June, 2023.

---

**MAYOR – MATTHEW SHOEMAKER**

---

**CITY CLERK – RACHEL TYCZINSKI**



## Fee Addendum Authorization

**Client Contract Change**  **Sub Contract Change**

**Project Name:** Asset Management Plan Consulting  
Engineering Services

**Change No.:** 1

**AECOM Project No.:** 60667706

**Date:** 19-Jun-23

**Client/Sub Name:** City of Sault Ste. Marie

**Contract Reference No.:** City SSM By-Law No.  
2021-167

**Subject:** Non-Core Asset Management Plans

Pursuant to the Agreement, the following change to the Scope of Work for the above project is advised:

**Description of Change:**

Fee Addendum to provide professional services to complete the Asset Management Plans (AMP) covering the City's non-core infrastructure (i.e., Protection Services, Solid Waste, Parks & Cemetery, Facilities, Fleet, Roadway Appurtenances, and Active Transportation), as well as provide recommendations on the ongoing maintenance of the City's asset management program. Refer to the attached Proposal dated May 25, 2023.

**Fee:** The agreed contract value will be:  unaltered,  increased,  decreased by Time & Materials - \$214,700.00 (AMT)

**Time:** The agreed time for completion is  unaltered,  increased,  decreased by 728 (calendar days)

Contract Value Summary		Time Changes Summary	
Original Contract Value	\$210,000.00	Original Contract Completion Date	30-Jun-22
Net value of changes previously authorized	\$210,000.00	Net Change Previously Authorized (calendar days)	0
This change	\$214,700.00	This Change (calendar days)	0
New Contract Value	\$424,700.00	New Contract Completion Date	28-Jun-24

## Fee Addendum Approval

Christiaan Lombard		1-Jun-23
<b>AECOM Project Manager</b>	<b>Signature</b>	<b>Date</b>
Rick Talvitie		1-Jun-23
<b>AECOM Authorized Signatory</b>	<b>Signature</b>	<b>Date</b>
Mayer - Matthew Shoemaker		
<b>City of Sault Ste. Marie</b>	<b>Signature</b>	<b>Date</b>
City Clerk - Rachel Tyczinski		
<b>City of Sault Ste. Marie</b>	<b>Signature</b>	<b>Date</b>
City of Sault Ste. Marie		
<b>City of Sault Ste. Marie</b>	<b>Signature</b>	<b>Date</b>

# Professional Services - Non-Core Asset Management Plans

City of Sault Ste. Marie

May 2023



AECOM, 523 Wellington Street East  
Sault Ste. Marie, Ontario Canada P6A 2M4

T: 705.942.2612  
F: 705.942.3642  
www.aecom.com

Catherine Taddo  
Manager, Development and Environmental Engineering  
The City of Sault Ste. Marie  
99 Foster Drive  
Sault Ste. Marie, ON P6A 5X6  
[c.taddo@cityssm.on.ca](mailto:c.taddo@cityssm.on.ca)

May 25, 2023

**Proposal #**  
04010225-2522

## ONLINE SUBMISSION

**Subject: Non-Core Asset Management Plans Proposal**

Dear Catherine:

AECOM Canada Ltd. (AECOM) is pleased to submit for the City's review and consideration our quotation to provide professional services to complete Asset Management Plans (AMP) covering the City's non-core infrastructure (i.e., Protection Services, Solid Waste, Parks & Cemetery, Facilities, Fleet, Roadway Appurtenances, and Active Transportation), as well as provide recommendations on the ongoing maintenance of the City's asset management program.

Our team has gained extensive experience working on projects of a similar size and nature, and we are therefore able to meet the specific requirements of this current project. AECOM's team is familiar with the City's technical, management and financial requirements for this assignment, and we can produce the required deliverables in an accurate, timely, and cost-effective manner.

AECOM's strengths and benefits to the City are as follows:



**We are a Trusted Service Provider for Asset Management (AM) Services** to municipalities in Ontario and across Canada, and the AECOM team proposed for this assignment has successfully delivered a wide variety of AM projects across North America. Our satisfied clients include the Regional Municipality of Peel, City of London, City of Vaughan, Town of Georgina, City of Guelph, City of Calgary, City of Winnipeg, City of Vancouver, City of Burnaby, Northern Sunrise County, City of Abbotsford, City of New Westminster, Capital Regional District, and Metro Vancouver.



**AECOM is an international best practice leader in AM.** AECOM is a Corporate Member, Endorsed Trainer, and Endorsed Assessor with the Institute of Asset Management (IAM). Our asset management approach is aligned with the International Organization of Standards (ISO) 55000:2014 Asset Management System Standards. In addition, AECOM contributed significantly to International Infrastructure Management Manual (IIMM), which is closely aligned with ISO 55001. In particular, AECOM is the principal author of the IIMM, 2000, 2002, 2003 & 2006, and made significant contributions to the 2011, 2015 & 2020 versions.





---

**Familiarity with the City of Sault Ste Marie.** AECOM has completed many projects with the City including the most recent Core AM Plans for Wastewater, Roads and Bridges, and Stormwater. AECOM staff are highly familiar with the City's non-core assets through local staff and their long history of providing infrastructure planning, design and construction support services to the City. AECOM will be able to work efficiently through all project tasks with the Teams' baseline understanding of the City's current AM practices, processes, and governance has previously been established. Furthermore, AECOM has been engaged in preliminary discussions to assist the City in establishing an appropriate hierarchy of non-core assets.



---

**Access to AECOM's Technical Practice Network.** AECOM's Technical Practice Network (TPN) is a network of technical practitioners as well as staff in functional roles, linking colleagues across business lines and global geographies. The Asset Management (AM) TPN is comprised of a community of 850 asset management employees globally, that fosters collaboration among the group members using a SharePoint website, a Chatter feed, training and collaboration webinars, mentoring, and live meetings. Through the SharePoint website, groups share reference materials, technical tools, standards, and marketing resources. AECOM's AM TPN is a gateway to collaborative networks designed to help our employees around the world share and advance technical knowledge and provide AECOM staff with quick access to information necessary to deliver services to our clients.



---

**Unparalleled Insights into the Requirements of O. Reg. 588/17.** Over the past two years, AECOM has successfully delivered 16 AM Plans for Ontario municipalizes to meet the requirements of O. Reg. 588/17, **six of which were for non-core assets like that of the City of Sault Ste Marie.** This experience provides us with unparalleled insights in the requirements of O. Reg. 588/17 and a deep understanding of how to link levels of service with the financial and operational needs related to these types of infrastructure assets.

---

We confirm AECOM has no actual or perceived conflict of interest related to this bid. We look forward to the next stage of the evaluation process. Should you have any questions regarding our submission, please do not hesitate to contact our **Project Manager, Christiaan Lombard, MBA, P.Eng.**, by cell at 604.314.6167, or by email to [christiaan.lombard@aecom.com](mailto:christiaan.lombard@aecom.com).

Sincerely,  
AECOM Canada Ltd.

---

Rick Talvitie, P. Eng.  
Associate Vice-President  
[rick.talvitie@aecom.com](mailto:rick.talvitie@aecom.com)

---

Christiaan Lombard, MBA, P.Eng.  
Project Manager  
[christiaan.lombard@aecom.com](mailto:christiaan.lombard@aecom.com)

# Proposal Assumptions and Limitations

AECOM will perform all professional services in accordance with the standard of care customarily observed by professional consulting firms performing similar services at the same time and location. The standard of care will include adherence to all applicable published standards of the profession and laws, regulations, by-laws, building codes and governmental rules.

AECOM Canada Ltd. is a wholly owned subsidiary of AECOM (NYSE: ACM). As with any large engineering company, AECOM's operating companies may become involved in claims, litigation, and alternative dispute resolutions (hereinafter "Claims").

AECOM does not comment on pending or past Claims for several reasons, including, but not limited to, a desire and need to maintain the attorney-client privilege, the protections of the attorney work product doctrine, and the private and confidential nature of settled Claims, which often are associated with confidentiality and non-disclosure agreements.

AECOM maintains adequate insurance for its professional services. Further, AECOM has no reason to believe that any of the Claims could reasonably be expected to materially impact AECOM's ability to perform services under this or any other contract. If you have further questions, please let us know.

## Prepared for:

Catherine Taddo

Manager, Development and Environmental Engineering  
City of Sault Ste. Marie  
The City of Sault Ste Marie  
99 Foster Drive  
Sault Ste. Marie, ON P6A 5X6

## Prepared by:

Christiaan Lombard, MBA, P.Eng.

AECOM Canada Ltd.  
3292 Production Way, Suite 330  
Burnaby, BC V5A 4R4  
Canada

T: 604.314.6167  
[www.aecom.com](http://www.aecom.com)



## Table of Contents

	page
<b>1. About Team’s Ability .....</b>	<b>1</b>
1.1 AECOM Corporate Profile.....	1
1.2 AECOM’s Past Experience .....	1
<b>2. AECOM Team Experience .....</b>	<b>3</b>
<b>3. Project Challenges and Risks .....</b>	<b>8</b>
<b>4. Work Plan .....</b>	<b>9</b>
Task 1: Project Management.....	9
Task 2: Background Information Review & Gap Analysis .....	9
Task 3: Asset Management Hierarchies .....	10
Task 4: Asset Management Plan Development .....	11
Task 4.1: State of Infrastructure Analysis.....	11
Task 4.2: Levels of Service .....	13
Task 4.3: Asset Lifecycle Strategies .....	14
Task 4.4: Financial Strategies .....	15
Task 5: Draft & Final AM Plan .....	18
<b>5. Project Schedule .....</b>	<b>19</b>
<b>6. Fees.....</b>	<b>21</b>

## List of Figures

Figure 2-1: Organization Chart .....	3
Figure 4-1: AECOM’s Project Management Approach .....	9
Figure 4-2: Sample State of the Infrastructure Dashboard .....	12
Figure 4-3: Universal Service Values.....	13
Figure 4-4: Translating Strategic LoS Objectives into Performance Measures.....	13
Figure 4-5: Example City of Vaughan Facility Assets Potential Future Demand Drivers .....	14
Figure 4-6: Lifecycle Cost Accumulation Over Asset Life .....	15
Figure 4-7: Non-Core Asset Funding Gap Analysis Sample.....	17
Figure 4-8: Sample outputs from the MS Excel Financial Dashboard .....	17
Figure 5-1: Project Schedule .....	20

## List of Tables

Table 2-1: Key Personnel and Relevant Project Experience .....	5
Table 3-1: Project Challenges & Risks and Measures to Ensure Project Success.....	8
Table 4-1: Sample Active Transportation Asset Hierarchy .....	10
Table 6-1: AECOM Pricing Proposal .....	22

# 1. About Team’s Ability

## 1.1 AECOM Corporate Profile



AECOM is built to deliver a better world. We design, build, finance and operate infrastructure assets for governments, businesses, and organizations in more than 150 countries. AECOM is a premier, fully integrated professional and technical services firm positioned to design, build, finance and operate infrastructure assets around the world for public and private sector clients. With nearly 57,000 employees — including architects, engineers, designers, planners, scientists and management and construction services professionals — AECOM remains atop Engineering News-Record's list of the Top 500 design firms where we are ranked #1 in General Building and Transportation. Our multi-disciplinary team is strategically deployed in offices across the Americas and worldwide. AECOM's unique perspective *brings together global resources with local expertise*.

Our teams are driven by a common purpose to deliver a better world through our unrivaled technical and digital expertise, a culture of equity, diversity and inclusion, and a commitment to environmental, social and governance priorities. AECOM's Professional Services business had revenue of US\$13.1 billion in fiscal year 2022.



Through this work, our team of management, business, engineering, and technical professionals has established a strong reputation and proven track record for delivering industry-leading solutions and for adding value to our clients' organizations. When combined with leading AECOM specialists from the US, Australia, New Zealand, and the UK, we are truly able to deliver world class solutions and expertise. Our philosophy is that to be effective, the concept of sustainability must be embraced as a way of doing business. To achieve true sustainability and meet the lifecycle needs in a fiscally responsible manner, the principles of sustainability and asset management should be aligned corporately, and be reflected in every process, decision, and activity an organization undertakes, including its approach to AM itself. More information on AECOM and its services can be found at [www.aecom.com](http://www.aecom.com).

AECOM provides its clients with a dedicated local team, while at the same time providing access to global expertise and services. Any work directed through this assignment will be completed out of our City of Sault Ste. Marie office. AECOM and its team are committed to providing high quality and prompt services to the City of Sault Ste. Marie.

AECOM, 523 Wellington Street East  
Sault Ste. Marie, Ontario Canada P6A 2M4  
T 705.942.2612 F 705.942.3642

Primary Contact: **Rick Talvitie, P.Eng.**  
(M): 705.971.2612  
rick.talvitie@aecom.com

In the field of Asset Management (AM), AECOM has occupied a unique position for over 25 years, beginning with our role in writing several AM manuals and guidelines which now define “best practice.” AECOM is a Corporate Member, Endorsed Trainer, and Endorsed Assessor with the Institute of Asset Management (IAM). Of the team identified for this project, *five (5) are IAM accredited*. Our approach to AM is aligned with the International Organization of Standards (ISO) 55000:2014 Asset Management System Standards and is informed by the International Infrastructure Management Manual (IIMM). AECOM is the principal author of the IIMM, 2000, 2002, 2003 and 2006, and made significant contributions to the 2011, 2015 and 2020 versions. AECOM also contributed to the ISO 55000 best practices.

## 1.2 AECOM’s Past Experience

The City of Sault Ste. Marie is proceeding with an asset management plan to comply with the second phase of the Regulatory requirements O. Reg. 588/17, in respect to its non-core municipal infrastructure assets. The successful delivery of this assignment is best achieved through experience in developing asset management plans for the City’s core asset management plans and experience in developing non-core asset management plans for other Municipalities coupled with knowledge and experience with the infrastructure itself. We believe AECOM is very well

© 2023 AECOM Canada Ltd. All Rights Reserved.  
This proposal may contain confidential information and may not be provided to anyone other than the addressee and its employees without AECOM's written consent.

positioned as demonstrated by our unparalleled knowledge and experience with the City's infrastructure and our successful development of similar plans for other municipalities. AECOM staff are very knowledgeable of the City's infrastructure through numerous past studies, capital upgrades and ongoing trouble shooting. Specifically, we have listed below various projects which we believe will be instrumental in assisting us in developing a comprehensive and quality asset management plan for the City:

- **City of Sault Ste Marie Wastewater Master Plan** – AECOM has completed Phase I of the two-phase Wastewater Master Planning project. The first phase included WWTP capacity assessment, detailed condition assessments of the wastewater facilities and the development of an all-pipes wastewater collection system model. Phase 2 has been initiated and includes flow monitoring and model calibration and the master planning exercise.
- **City of Sault Ste Marie Core Asset Management Plans** – AECOM prepared asset management plans for the City's Wastewater, Stormwater, and Roads & Bridges in compliance to the Ontario Regulation 588/17 Phase I requirements.
- **Wastewater Advisory Services** – We have been engaged by the City for 10 years to assist with troubleshooting and upgrading various elements of the City's wastewater infrastructure including SCADA. This project has then resulted in numerous smaller capital projects to repair or upgrade various infrastructure components. Through this work we have gained tremendous knowledge and insight regarding the City's waster water treatment, pumping and collection system assets.
- **Large Wastewater Facilities Asset Inventory and Condition Assessment** – in 2013-2014 we prepared a high-level inventory and condition assessment of the various components of the seven large pump stations and two wastewater treatment plants. The excel templates included condition ratings from poor to excellent, recommendations for maintenance, repairs or replacement, an opinion of probable costs and a 20-year capital plan.
- **WEWPCP Upgrading Study and WEWPCP Phase I Upgrades** – in 2012 we completed a comprehensive review of the WEWPCP to assess the capacity, assess the condition of the various facility components and to identify upgrading needs. We were subsequently engaged to complete preliminary and detail designs, tendering and contract administration and construction inspection for the \$30M+ upgrading project.
- **EEWPCP BNR Treatment Upgrades** – in the early 2000's AECOM completed the preliminary and detail designs, contract administration and construction inspection for the upgrading of the City's east end primary treatment facility to a Biological Nutrient Treatment Facility.
- **Small Wastewater Pumping Station Replacements or Upgrades** - Over the period from 2013 to present we have provided engineering services for the replacement of three pump stations and upgrades to eight pumping stations.
- **Large Wastewater Pumping Station Upgrades** – AECOM has also been involved with some form of upgrades at the Bellevue, Main, Young Street, John Street, River Road and Clark Creek pump stations.
- **Linear Reconstruction Projects** - Our Sault Ste. Marie Team has been involved in numerous linear reconstruction projects which have incorporated the replacement and upgrading of storm sewers and sanitary sewers across the municipality. Through these undertakings we have a thorough knowledge of the existing linear infrastructure and the range of pipe types and ages.
- **River Road PS Forcemain and South Market Storm Sewer Condition Assessment** - We engaged the specialist services of Chris Macey to assist the City in reviewing and assessing the condition of the River Road forcemain and South Market storm sewer. This included consideration of probable condition, future risks and proposed remediation approaches where appropriate.
- **Waste Management Planning and Design** - AECOM has been extensively involved with the City's waste management services for over two decades Through these assignments which has included planning activities as well as landfill site upgrades and additions we have a very thorough understanding of the various infrastructure elements and their costs and condition. We have also developed a comprehensive business plan which can be incorporated into the asset management planning framework.
- **Bellevue and Pim Street SSO's and associated Pump Station Construction or Upgrades** – AECOM completed the preliminary and detail designs, contract administration and construction inspection for these two SSO facilities. This included the construction of the Bellevue PS and upgrading of the Pim Street PS.
- **Stormwater Financing Study** – AECOM has advanced a stormwater financing study on behalf of the City of Sault Ste. Marie. The study was placed on hold but included asset inventorying and valuation and identification of a preferred cost recovery model.

## 2. AECOM Team Experience

The success of any project depends on the experience and expertise of the individuals assigned and the blending of their talents to achieve the project deliverables. The individuals presented in the organizational chart in **Figure 2-1** below have been carefully selected whose expertise, experience, and personal strengths best match the requirements of this assignment. **Table 2-1** provides more details regarding each team member’s relevant experience.

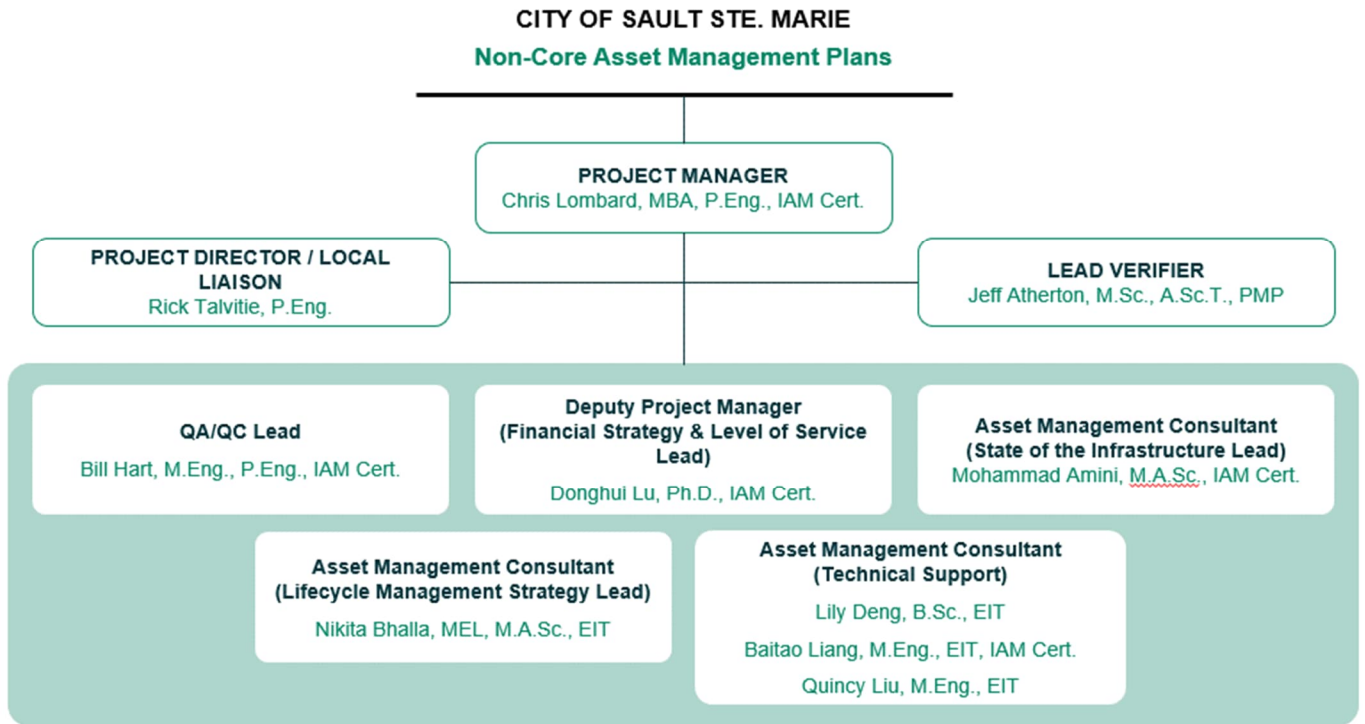

Figure 2-1: Organization Chart



**Chris Lombard, MBA, P.Eng., IAM Cert.**

**Project Manager**

Chris is AECOM’s Asset Management Leader for the Americas Water, specializing in AM policy, strategy, and planning. In his career spanning nearly three decades, he has successfully directed and supported large and multi-disciplinary AM assignments for clients on four continents. He has experience covering major asset types such as transit, highways, bridges, dams, municipal, ports, airports, facilities, health care, utilities, nuclear and natural assets. As Asset Management Technical Practice Group Leader, he is also responsible for curating AECOM’s institutional memory and knowledge transfer related to AM projects, methodologies, and standards. He currently serves on the Executive Committee of the American Society of Civil Engineers’ Utility Engineering and Surveying Institute (UESI), and is on the Advisory Team for the University of British Columbia’s Masters Degree in Engineering Leadership in Urban Systems.

**Why Nominated:**

- Chris is the winner of the 2023 Canadian Network of Asset Managers (CNAM) [Visionary Award](#) recognizing an individual who has made an integral contribution and long-term dedication in advancing the asset management industry in Canada.

- 28 Years of project management experience in developing AM Programs for agencies across Canada, including the Township of Langley, City of Edmonton, Town of Georgina, City of Vaughan, City of Vancouver, City of North Vancouver, City of Surrey, City of Abbotsford, City of Prince George, and regional organizations such as the South Coast British Columbia Transportation Authority, Metro Vancouver, Port of Vancouver, and the Comox Valley Regional District.
- Deep experience with advising clients on AM strategy, capital improvement planning and levels of service, including the City of Sault Ste. Marie.
- Extensive municipal AM knowledge with over two decades of experience as a senior project resource for the Canadian Infrastructure Benchmarking Initiative (CIBI, <https://www.nationalbenchmarking.com/>).
- Chris is Institute of Asset Management (IAM) accredited and has undergone formal facilitation training. Chris leads AECOM's IAM Training and conducts workshops regularly as part of the training program for internal and external clients (see <https://aecom.kineoport.com>).

### Recent Relevant Experience:

Chris was the Project Manager on the following list of recently completed AM assignments.

- **City of Vaughan – Renewal of Corporate AM Strategy + Development of AMPs for Core and Non-Core Assets** (Completed 2022) to meet O. Reg 588/17 deadline. Reference: Justin Wong, Project Manager, Infrastructure Planning and Corporate Asset Management, 905-832-8585 ext. 8725 | [justin.wong@vaughan.ca](mailto:justin.wong@vaughan.ca).
- **Town of Georgina - Asset Management Plans - Core Infrastructure** (Completed 2022) to meet O. Reg 588/17 deadline. Reference Nancy Fleming Manager, Asset management and Technical Services +1.905.476.4301, [nfleming@georgina.ca](mailto:nfleming@georgina.ca).
- **City of Vancouver Board of Parks and Recreation Asset Management Plan for Park Infrastructure** (Completed 2021). Reference: Pouyan Keshtkaran | Asset Planner, Vancouver Board of Parks, and Recreation, +1.605.654.0765, [Pouyan.Keshtkaran@vancouver.ca](mailto:Pouyan.Keshtkaran@vancouver.ca).
- **City of Edmonton: Active Modes & Circulation Asset Management Plan** (Completed 2020): Reference: Murray Johnson, Supervisor, Infrastructure Planning & Design, +1.780.496. 5302, [Murray.johnson@edmonton.ca](mailto:Murray.johnson@edmonton.ca).
- **City of Sault St. Marie Asset Management Plan - Core Infrastructure** (Completed 2022) to meet O. Reg 588/17 deadline. Reference: Catherine Taddo Manager, Development and Environmental Engineering +1.705.759.5380, [c.taddo@cityssm.on.ca](mailto:c.taddo@cityssm.on.ca).
- **Township of Langley: Natural Capital Asset Management Plan** (Completed 2022). Reference: Hakim Bismel, Infrastructure Asset Manager, Engineering Division, +1.604.532.3543, [hbismel@tol.ca](mailto:hbismel@tol.ca).
- **City of Prince George Corporate-Wide Levels of Service Development** (Completed 2020). Reference: Kristy Bobbie, ASCT, Asset Manager, Asset Management Division, +1.250.561.7518, [kristy.bobbie@princegeorge.ca](mailto:kristy.bobbie@princegeorge.ca).
- **City of Edmonton: Open Space Asset Management Plan** (draft report submitted December 2022): Reference: Murray Johnson, Supervisor, Infrastructure Planning & Design, +1.780.496. 5302, [Murray.johnson@edmonton.ca](mailto:Murray.johnson@edmonton.ca).

### Rick Talvitie, P.Eng.

### Project Director / Local Liaison

Rick has 35 years of experience, specializing in transportation, municipal, and environmental engineering. He has extensive experience working from project planning, through to contract completion in the areas of municipal servicing, water and wastewater treatment, road and highway design, and municipal solid waste management. Rick is the Manager of the Sault Ste. Marie office of AECOM and is well known to City staff. He has 35 years of experience and has been actively involved in SSM infrastructure projects for 30+ years. He has a keen understanding of asset management principles and a broad knowledge of the core infrastructure assets that will be addressed through this study. We have learned through past assignments that local involvement from start to finish and will ensure the deliverables meet the City's expectations.

Table 2-1: Key Personnel and Relevant Project Experience

Key Personnel / Proposed Role	Background Summary	Education	Professional Affiliation(s)	Years of Experience	Relevant Recent Experiences
<b>Jeff Atherton, M.Sc., A.Sc.T., PMP Lead Verifier</b>	Jeff is senior project manager and lead technical specialist within AECOM's Infrastructure Services Group. Jeff has over 20 years of project management experience in the municipal infrastructure industry with extensive linear and vertical asset condition assessment project portfolios. He oversees AECOM's deliver of flow monitoring, hydraulic modelling, water resources and asset management. Along with the technical expertise to lead this project, Jeff brings a genuine passion for managing sewers condition, deterioration, and rehabilitation projects and for delivering a high-quality product. Client focused and responsive.	M.Sc., Surveying, University of New Brunswick B.Sc., Mount Allison University Certificate of Engineering, Mount Allison University Advanced Diploma (GIS), College of Geographic Science	Project Management Institute (PMI) 5706593 Member, Ontario Association of Certified Engineering Technicians and Technologists NASSCO PACP/ MACP/LACP U-1018-0703003674	Years Exp.:22 With AECOM:17	<ul style="list-style-type: none"> <li><b>City of Toronto, Local and Trunk Sewer Condition Assessment Program.</b> Program Manager for the City's linear wastewater assessment 5-year (2019/2024) program. He's currently overseeing the administration and delivery of an annual 10 million capital program which includes the assessment and rehabilitation of 750 km of gravity sewers and 10,000 manhole inspections in a single year. As part of the program AECOM is validating contractor CCTV specifications adherence. AECOM is developing a comprehensive rehabilitation program which includes capital budgeting and the use of advanced trenchless technologies within InfoAsset Manager.</li> <li><b>City of Hamilton, Critical Watermain Rating System.</b> Project Manager developed an overall management approach for managing 'critical' water mains within the City. Toolsets that were developed include a condition rating consolidation system using fuzzy sets, an assessment technique rationalization system, and a set of decision trees for planning intervention approaches for critical water mains. Tool currently being used for capital planning and risk management of critical water mains within the City.</li> <li><b>Detroit Water and Sewage Department, Capital Improvement Program Management.</b> Technical lead for the integration of asset condition assessment which will be used to develop and prioritize a comprehensive capital improvement program.</li> </ul>
<b>Bill Hart, M.Eng., P.Eng., IAM Cert. QA/QC Lead</b>	Bill has extensive experience in maintenance and operations, across asset integrity and condition assessment projects for several industries such as oil and gas, mining, pulp and paper, and chemicals. Bill has led multi-disciplinary teams within high hazard industries as an operator and service-provider. In-depth knowledge of maintenance & inspection strategies and approaches for static equipment.	Master of Engineering, 1 <sup>st</sup> Class (Hons.), Mechanical Engineering	P.Eng. (#55469) API 653 (#101689) API 580 (#96503)	Yrs. of Exp.: 12 With AECOM: <1	<ul style="list-style-type: none"> <li><b>Metro Vancouver Seymour Capilano Pressure Equipment Inspection.</b> Planned and executed detailed inspection with NDE of all pressure vessels at MV's Seymour Capilano water treatment facility.</li> <li><b>Metro Vancouver Mains Condition Assessment.</b> Planned and executed site assessment of valve chambers for Metro Vancouver and completed Engineering studies of data to conclude remaining life and repair requirements.</li> <li><b>FortisBC.</b> Project managed water piping inspection and condition assessment on behalf of FortisBC at operated hydroelectric dams on the Kootenay River.</li> <li><b>Pipeline inspection and maintenance.</b> Managed inspection, maintenance, and condition assessment (including life cycle planning) of liquid and gas pipelines for UK utilities. Included onshore, offshore, submerged, and buried pipelines.</li> </ul>
<b>Donghui Lu, Ph.D., IAM Cert. Deputy Project Manager (Financial Strategy &amp; Level of Service Lead)</b>	Donghui has extensive asset management planning experience with Canadian municipalities across a variety of asset classes including water, wastewater, stormwater, transportation, and non-core assets to help clients advance their asset management practices. Donghui's specialties include asset management strategic planning, risk assessment, performance modeling, life cycle cost analysis, operations & maintenance strategies, capital planning, and climate change risk assessment & adaptation.	Ph.D., Civil Engineering, University of Waterloo, Ontario Ph.D., Agricultural and Biological Engineering, China Agricultural University, Beijing	Professional Engineers Ontario's Engineering Intern (EIT), Ontario Certificate in Asset Management, Institute of Asset Management	Yrs. of Exp.: 7 With AECOM: > 2	<ul style="list-style-type: none"> <li><b>City of Vaughan Renewal of Asset Management Strategies and Asset Management Plans for Core and Non-Core Assets.</b> Developed corporate asset management strategies and asset management plans for water, wastewater, stormwater, roads &amp; bridges, urban forestry, roadway appurtenance, parks, fire &amp; rescue, fleet, and facilities ensuring compliance with Ontario Regulation 588/17.</li> <li><b>Town of Georgina, Development of An Asset Management Plan O. Reg 588/17 Core Infrastructure.</b> Asset management consultant developing asset management plans for the Georgina's roads, bridges &amp; culverts, water, wastewater, stormwater assets ensuring compliance with Ontario Regulation 588/17.</li> <li><b>City of Sault Ste. Marie, Sault Ste. Marie Asset Management Plans.</b> Asset management consultant developing asset management plans for the City's roads, bridges &amp; culverts, wastewater, stormwater assets ensuring compliance with Ontario Regulation 588/17.</li> <li><b>Reginal District of Central Okanagan. Asset Management Plan - Westside Regional Wastewater Treatment Plant.</b> Asset Management Data lead responsible for condition data QA/QC, asset inventory and state of infrastructure analysis, risk and financial dashboards, level of service analysis, demand analysis, and development of asset management plan.</li> <li><b>National Water and Wastewater Benchmarking Initiative.</b> Client manager for data collection, workshop facilitation and client liaison. Performance data analyst supporting transportation benchmarking clients across Canada.</li> </ul>
<b>Mohammad Amini, M.A.Sc., IAM Cert. AM Consultant (State of the Infrastructure Lead)</b>	Mohammad is an Asset Management Consultant supporting the development of asset management plans. His specialties include asset management planning, risk assessment frameworks, and life cycle cost analysis. His experience covers a wide variety of asset categories such as water, wastewater, stormwater, facilities and natural assets. He also has some experience in relation with data mining and machine learning.	M.A.Sc., Civil Engineering, Concordia University B.Sc., Civil Engineering Azad University, Iran	Engineering in Training (EIT), EGBC IAM Certificate Candidate	Yrs. of Exp.: 6 With AECOM: 1	<ul style="list-style-type: none"> <li><b>City of North Vancouver Asset Management Plan: water, sanitary, and drainage.</b> Applying lifecycle cost strategies to City of North Vancouver water, wastewater, and stormwater assets. Generating report and state of the infrastructure based on the available datasets. Extracting results from Brightly Predictor tool</li> <li><b>Natural Capital Asset Management Plan, Township of Langley.</b> Apply life cycle cost analysis technique to propose an annual O&amp;M and Capital expenditure to Township of Langley based on current budget and desire budget. Accordingly, generating an excel-based dashboard that can be shown based on different scenarios. Compiling a list of available resources that Township of Langley could leverage in order to maintain natural assets.</li> </ul>

Key Personnel / Proposed Role	Background Summary	Education	Professional Affiliation(s)	Years of Experience	Relevant Recent Experiences
					<ul style="list-style-type: none"> <li>• <b>Long-Term Capital Planning, Township of Langley.</b> Develop a long-term capital planning and prioritization tools that assimilates all its core asset classes, based on the available information, such as GIS-based information, current practices, previous asset management plans and capital planning tools.</li> <li>• <b>City of Sault Ste. Marie Wastewater Asset Management Plan.</b> Compile and prepare state of the infrastructure report based on the various attributes, such as condition of sewers, pump stations, etc. Perform life cycle cost analysis for wastewater network and create an excel-based dashboard to the client. Preparing the wastewater asset management plan, including state of the infrastructure, life cycle analysis, and recommendations.</li> </ul>
<b>Nikita Bhalla, MEL, M.Sc., EIT. AM Consultant (Lifecycle Management Strategy Lead)</b>	Nikita is an asset management consultant with four years experience in in private and public sector adopting holistic approach, strategizing, designing to maintaining the infrastructure throughout its life cycle for sustainable development.	Master of Engineering Leadership (MEL), Urban Systems Honours, University of British Columbia Master in Structural Engineering, Gold Medalist, Thapar University, Patiala, India Bachelor's in Civil Engineering, Silver Medalist, Guru Nanak Dev Engineering College, Ludhiana, India	Engineers and Geoscientists of British Columbia Engineer-in-Training (EIT)	Yrs. of Exp.: 5 With AECOM: 1	<ul style="list-style-type: none"> <li>• <b>Natural Capital Asset Management Plan, Township of Langley, BC.</b> Responsible for development of the natural asset management plan for various natural asset classes such as water, aquifer, trees, forest, shrubland by identifying data gaps, gathering relevant asset attributes; performing economic valuations based on best practices and benchmarking data; and carving out life-cycle strategies in consultations with the municipality staff.</li> <li>• <b>Asset Management Services, AECOM, BC. (Seconded to TransLink).</b> As a contractor at TransLink supported the Corporate Asset Management Strategy team. Updated asset categorization project for determining asset criticality; developed asset renewal programs to support the 10-year capital investment planning which included analyzing data to determine the current and future asset condition, asset replacement needs based on condition assessments/target useful life and estimating current as well as future replacement value of each asset class. Assisted in enhancing the existing enterprise asset inventory with the objective to break down the inventory to more granular level to meet enterprise business needs.</li> <li>• <b>Facility condition assessment, City of Prince George, BC.</b> On-site support for inspecting and capturing the mechanical components of various facilities, including, fire halls, recreation, art gallery, RCMP and other City owned senior activity centers using AECOM Assessor for Builder application.</li> </ul>
<b>Lily Deng, B.Sc., EIT AM Consultant (Technical Support)</b>	Lily is an Asset Management Consultant in the Burnaby, British Columbia Office. She acts as the client account manager for the Canadian Infrastructure Benchmarking Initiative and has worked with municipalities across Canada to benchmarking data across various utilities. She is familiar with the design of pumping systems, sewage treatment systems, and wastewater treatment plants. Lily has experience performing energy analyses, and hydraulic optimization studies.	Bachelor of Science (B.Sc.), Civil Engineering, Specialization in Energy and Environmental Engineering, University of Calgary, 2020	Engineering in Training (EIT)	Yrs. of Exp.: 4 With AECOM: 4	<ul style="list-style-type: none"> <li>• <b>Canadian Infrastructure Benchmarking Initiative, Burnaby, BC.</b> Acted as the client account manager for 50+ participating municipalities across Canada. Assisted clients with data collection, training across water, wastewater and transportation utilities. Worked with the project team to maintain a data portal website and perform data quality checks to ensure accurate delivery of results.</li> <li>• <b>Town of Georgina Core Infrastructure Asset Management Plan Software Strategy.</b> Supported the development of AM Software Strategy for Town of Georgina. Analyzed the industry software on asset management decision support system.</li> <li>• <b>City of Calgary, Closed Zone Energy Optimization, Calgary, AB.</b> Analyzed the hydraulic and energy performance of nine potable water pump stations. Analyses included comparison of field collected hydraulic data with expected factory performance. Performed detailed energy analyses to review energy consumption by pumps, and wasted energy consumed through bypass line pumping. Provided further recommendations to reduce energy usage, reduce greenhouse gas emissions, and increase energy efficiency at all stations.</li> </ul>
<b>Baitao Liang, M.Eng., EIT, IAM Cert. AM Consultant (Technical Support)</b>	Baitao Liang is a junior asset management consultant at AECOM in the Burnaby office with experience analyzing and assessing the performance of engineering systems for both the private and public sector. His project experiences have involved municipal asset management, facilities condition assessment, and risk management. Baitao's skills include data analysis, life cycle analysis, risk modeling, cost estimation and project management. Also possesses experience with asset management related software such as Ameresco AssetPlanner, InfoAsset Planner, infor EAM, Cityworks, etc.	Master of Engineering, Project and Construction Management, Co-operative Education, University of British Columbia, Vancouver, BC 2019 Bachelor of Applied Science in Civil Engineering, Co-operative Education, University of British Columbia, Vancouver, BC, 2016	Association of Professional Engineers and Geoscientists of BC (APEG BC) China Civil Engineering Society (CCES)	Yrs. of Exp.: 7 With AECOM: 4	<ul style="list-style-type: none"> <li>• <b>Infrastructure Asset Management Strategies and Services, Metro Vancouver, BC, 2022.</b> Responsible for analyzing and improving business processes and needs by providing strategic input. Involved in multiple infrastructure asset management strategic planning including asset registry, Levels of Service, condition assessments and risk assessments. Prepared and tracked financial plans using project management principles ensuring the effective and efficient expenditure of allocated funds on different aspects of asset management.</li> <li>• <b>Resort Municipality of Whistler, Building Condition Assessments &amp; Life Cycle Report, BC.</b> Contributed to the condition assessment analysis of 58 independent facilities and cost estimation using RSMMeans. Also contributed to the QA/QC of the assessment data, and creating reporting summaries including list of deficiencies, recommendations on expenditures, and long-term lifecycle analysis.</li> <li>• <b>Full-Time Secondment at Metro Vancouver Project Delivery Office, 2020 – 2021, BC.</b> Responsible for the development and support of Asset Assessment Plans (AAP) at Metro Van, including data compilation, criticality &amp; risk assignment, stakeholder engagement, supporting the use of the AAPs moving forward, and reporting. Involved projects include LIWWTP and AIWWTP buried piping AAP; Water Services Chambers, River Crossings and Pump Stations AAP; Liquid Waste Services Pump Stations AAP.</li> </ul>



Key Personnel / Proposed Role	Background Summary	Education	Professional Affiliation(s)	Years of Experience	Relevant Recent Experiences
<p><b>Quincy Liu, M.Eng., EIT AM Consultant (Technical Support)</b></p>	<p>Quincy has an education background in Civil Engineering and project management. During the past years, he led and participated in different property condition assessments, reserve fund studies and life cycle analyses for private and public clients, including residential, commercial, and institutional buildings. He has a firm understanding of building science and asset management. He is currently an Engineer II in the Water Canada, Asset Management Team. He has experience in all stages of project delivery including project planning, data processing, site inspection, technical report compilation, and project management support services.</p>	<ul style="list-style-type: none"> <li>• Master of Engineering, Project and Construction Management, The University of British Columbia (UBC)</li> <li>• Bachelor of Applied Science, Civil Engineering, The University of British Columbia (UBC)</li> </ul>	<ul style="list-style-type: none"> <li>• Engineering In Training (EIT), Association of Professional Engineers and Geoscientists of B.C (APEGBC)</li> <li>• IAM Certificate Candidate</li> </ul>	<p>Years Exp.: 4 With AECOM: 1</p>	<ul style="list-style-type: none"> <li>• <b>Facility Condition Assessment Phase III, Resort Municipality of Whistler, BC.</b> Engaged in the project team of the facility condition of 58 independent properties. Participate in the safety work plans, UNIFORMAT build-up, RSMMeans profile (Square-footage estimate, and Life Cycle Cost Estimate), Fulcrum App set-up, site inspection and final deliverable compilation. A 10-year short-team and 50-year long-term capital expenditure plans will be presented in the final technical reports, with different funding scenarios.</li> <li>• <b>City of Richmond – Park Asset Management Report, Richmond, BC. This project is preparing the Asset Management Plan for Natural and Engineered Assets owned and managed by City of Richmond, Park Department.</b> Engage in the project team working on the State of Infrastructure analysis, Capital, and Operating &amp; Maintenance financial planning.</li> <li>• <b>RDKB Asset Management Consulting Service - Regional District of Kootenay Boundary, BC.</b> This project is preparing the Asset Management Plan for Utility (Water and Wastewater), Environmental, Public Service, and Facility &amp; Recreation Assets owned and managed by RDKB. Engage in the project team majorly working on the State of Infrastructure analysis, Capital, and Operating &amp; Maintenance financial planning.</li> </ul>

### 3. Project Challenges and Risks

AECOM has identified several anticipated project challenges and risks along with what measures will be advised to ensure project success. These are outlined in **Table 3-1** that follows:

**Table 3-1: Project Challenges & Risks and Measures to Ensure Project Success**

Challenges & Risks	Measures to Ensure Project Success
<b>Coordination with City project and AM stakeholders</b>	Establish roles, responsibilities, and lines of communication at project outset. Conduct monthly project coordination / progress meetings with key City staff to e.g., confirm that project is on track, establish dates for meetings and workshops and explore data gaps and solutions.
<b>Meeting project schedule – tight timelines for project completion to meet O. Reg. 588/17 deadline</b>	Dedicated AECOM resources that have worked successfully on similar projects recently, meeting tight schedules. Develop a detailed with four-week look-ahead and incorporate contingency planning. Have recovery plan for unforeseen conditions. Allow adequate time for City review of deliverables and plan to have draft AMPs ready three months and final AMPs a month in advance of O. Reg. 588/17 deadline,
<b>Quality of existing asset register &amp; asset attributes</b>	AECOM to develop a detailed data request at project outset and work closely with City to confirm that all available City information has been provided. AECOM team to review data and identify gaps to be addressed during State of Infrastructure task. AECOM understands very well that to properly support the objectives of AM within the City, its asset inventory must be granular enough to identify which individual assets are due for renewal (refurbishment or replacement), or which assets are subject to O&M interventions; however, we also understand the fine balance between adequate granularity to provide the necessary information and too much granularity that the effort to collect and manage the information outweighs the usefulness of the data itself.
<b>Development of Levels of Service (LoS) for non-core assets</b>	O. Reg. 588/17 is silent on the LoS for non-core assets, which means that the project team will have to work with the City to develop LoS for the complex range of assets (Protection Services, Solid Waste, Parks & Cemetery, Facilities, Fleet, Roadway Appurtenances, and Active Transportation) within the project scope. Fortunately, AECOM has a library of LoS applied at other Canadian municipalities that could be considered by the City, and we have a well-versed methodology of working with municipalities to develop LoS for all types of assets.
<b>Accuracy of cost requirements associated with the proposed lifecycle strategies</b>	Asset lifecycle needs to be identified through desktop asset assessment and remaining useful life analysis as well as a summary of current and planned projects. AECOM will consult with City Finance and cross-check asset replacement values against AECOM library of non-core asset costs as well as our RSMeans cost database (see <a href="https://www.rsmeans.com/">https://www.rsmeans.com/</a> ).

## 4. Work Plan

The asset management requirements as per O. Reg. 588/17 shall form the basis of the proposed work program outlined in the workplan below. The non-core assets to be included in the workplan scope, as defined by the regulation, include the City's Protection Services, Solid Waste, Parks & Cemetery, Facilities, Fleet, Roadway Appurtenances, and Active Transportation assets.

### Task 1: Project Management

AECOM has developed a set of Corporate Project Management standard policies, procedures, and practices, developed over decades of project work, that guide our people to high-quality program/project management. The AECOM Project Management Approach **Figure 4-1** confirms clarity of scope, schedule, and systems, creating a uniform and common set of systems, protocols, and knowledge – prerequisites to developing and maintaining a collaborative working environment.

AECOM's certified Project Managers will proactively manage roster projects by:

- Providing timely and accurate status reports by tracking and comparing expenditures to budget and progress and tracking and updating the schedule.
- Providing budget control and financial management
- Maintaining project schedule by meeting major milestones and assisting the City with the timely review of milestone submittals.
- Anticipating project challenges, and proactively developing alternative solutions.
- Acting decisively rather than reacting after problems occur
- Informing the City of all project related activities.

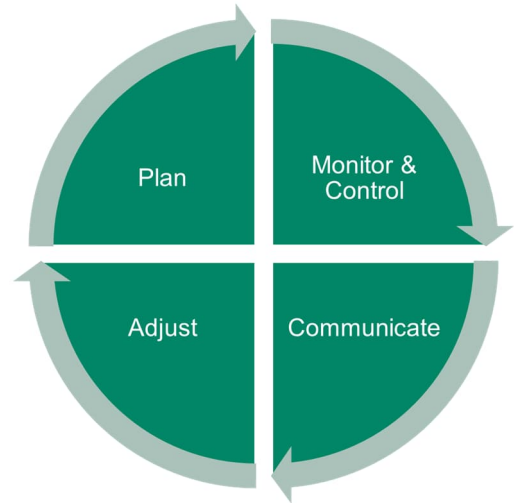

**Figure 4-1: AECOM's Project Management Approach**

Good project management is vital to project success. We help our clients meet their project objectives by acting as an extension of their organisation and protecting their interests as our own. AECOM has strict project management protocols and systems in place so that we offer the very best service to our clients.

### Task 2: Background Information Review & Gap Analysis

AECOM recognizes that clear and well-defined milestones and regular communication with the City will support the achievement of project deadlines and will be a key component to the success of the overall project. Upon award of the contract, a project kick-off meeting will be held virtually with key staff members to establish formal lines of communication, determine project success factors, and to confirm the project scope, deliverables, and schedule (please refer to our Project Schedule for task sequencing, duration, and milestones). AECOM views the City's staff as subject matter experts (SME's) over their designated areas and recognizes that communication and liaison is essential to the success of this project. AECOM will provide an agenda three business days prior to the project kick-off meeting and meeting minutes will be provided within three days after the meeting date.

AECOM will work with our internal technical and AM experts to assemble a data request to review and update the City's existing asset inventory. In turn, AECOM will work with key staff to gather appropriate asset

data, and any information pertaining to the City’s current AM practices. Information sources will be carefully documented and reviewed throughout the remaining sub tasks and will form the foundation of the work going forward. It is understood that, where existing data and information is available, the City will provide:

- GIS asset inventory including the number of assets, location, quantity, and related condition data.
- Key strategic documents and background reports.
- O&M and capital planning programs and budgets.
- Existing asset valuation data.
- Other relevant asset management information as applicable.

A robust and comprehensive asset inventory will support the City in making informed, strategic decisions about its core infrastructure assets. By updating this information, the City can be proactive about managing any risks or costs associated with the renewal and replacement of its assets. The asset inventory must be granular enough to identify which individual assets are due for renewal (refurbishment or replacement). However, it is important to note the fine balance between adequate granularity to provide the necessary information, and too much granularity that the effort to collect and manage the information outweighs the usefulness of the data itself.

Once the asset inventory is compiled with applicable attributes populated where available, AECOM will be in a good position to commence the data gap analysis process. An asset inventory summary will be presented to the City, along with recommendations and methods on how to collect or obtain missing data to close any gaps in the asset inventory. AECOM will then summarize any data gaps which will be brought forth as recommended improvement initiatives in the final AM Plans.

### Task 3: Asset Management Hierarchies

It is AECOM's experience that the compilation of the asset inventory and structure is one of the most critical tasks in developing an AM Plan, therefore AECOM will work diligently with the City to consult all available sources of asset information to ensure that all core assets are reflected in the inventory, together with the pertinent asset attributes needed for the state of infrastructure analysis. In this task, AECOM will develop an asset data hierarchy for the different asset categories and subcategories based on available standards if the existing structure is not sufficient. AECOM will ensure that the asset inventory maintains backward integrity with the City’s GIS through the unique identifier of each asset, and that the inventory contains adequate resolution for performing analysis according to the requirements set by the City. **Table 4-1** presents a sample active transportation asset hierarchy that AECOM recently developed for one of our clients.

**Table 4-1: Sample Active Transportation Asset Hierarchy**

Asset Group	Asset Category	Asset Type
Active Transportation, Sidewalks & Walkways	Sidewalks	Sidewalk
	Sidewalks	Walkway
	Cycling Facilities	Bike Lane
	Cycling Facilities	Protected Bike Lane
	Cycling Facilities	Buffered Bike Lanes
	Cycling Facilities	Cycle Tracks
	Cycling Facilities	Cycle Track
	Cycling Facilities	Shared Roadway (Signed)
	Cycling Facilities	Shared Roadway (Unsigned)

Asset Group	Asset Category	Asset Type
	Cycling Facilities	Paved Shoulder
	Multi-use Recreational Trail Infrastructure	Off-Road Hiking Trail
	Multi-use Recreational Trail Infrastructure	Connection
	Multi-use Recreational Trail Infrastructure	Off-Road Multi-Use Trail
	Multi-use Recreational Trail Infrastructure	Off Road Bike Lane
	Multi-use Recreational Trail Infrastructure	Granular / Natural, and others
	Multi-use Recreational Trail Infrastructure	Multi Use
	Multi-use Recreational Trail Infrastructure	Multi-Use Pathway
	Shared-use Pathways	Shared Pathway

## Task 4: Asset Management Plan Development

Applying AECOM's project approach to the methodology presented in this section will result in reliable, robust, and useful information from which the City can have confidence to make fact-based, defensible business decisions with regard to their core infrastructure. The development of the AM Plan, in accordance with the O.Reg 588.17, will draw from our capabilities and proficiency with the following standards and guidelines to provide value added information and to establish an AM improvement plan for the City:

- NAMS IIMM International Infrastructure Management Manual 6<sup>th</sup> Edition (2021), of which AECOM was, and still is, a key contributor.
- ISO 5500X Asset Management (includes ISO 55000, ISO 55001 and ISO 55002).
- Ontario Building Together: Guide for Municipal Asset Management Plans.
- Ontario Regulation 588.17: Asset Management Planning for Municipal Infrastructure.

### Task 4.1: State of Infrastructure Analysis

AECOM compares the current state of the collected data with the desired level of data to determine whether the City's data is satisfying the expectation of the required information for having a comprehensive and effective AMP. AECOM will then summarize the data gaps and discuss them with the City's project team to enhance and fulfill the identified gaps. It is AECOM's experience that the compilation of the asset inventory is one of the most critical tasks in developing an AMP, therefore AECOM will work diligently with the City to consult all available sources of asset information to ensure that all assets are reflected in the inventory, together with the pertinent asset attributes needed for the state of infrastructure analysis.

In this task, AECOM will review and update asset data hierarchy for the different asset categories (i.e., **Protection Services, Solid Waste, Parks & Cemetery, Facilities, Fleet, Roadway Appurtenances, and Active Transportation**) and subcategories (e.g., linear, and non-linear) based on available standards if the existing structure is not sufficient. AECOM will confirm that the asset inventory maintains backward integrity with the City's database through the unique identifier of each asset, and that the inventory contains adequate resolution for performing analysis according to the requirements set by the City.

Defining the state of the infrastructure involves quantifying the assets owned, examining their age, replacement value, and other characteristics, including but not limited to the following:

- Inventory Summary and Inventory Dashboard.
- Estimated Service Life, Remaining Service Life, and Age.

- Physical Condition and Deterioration Curves.

**Task 4.1.1: Estimated Replacement Value**

Based on the previous projects and the values currently available in the market, as well as a discussion with the City’s staff, AECOM will propose unit replacement/renewal values for the current assets within the non-core asset groups.

**Task 4.1.2: Asset Age and ESLs**

The estimated service life (ESL) is defined as the period over which an asset is available for use and able to provide the required level of service at an acceptable risk (i.e., without unforeseen costs of disruption for maintenance and repair). The ESL for this assignment will be based on discussions with the City’s staff, information from previous studies, and any additional information that might inform the ESL.

As a starting point for determining the Remaining Service Life (RSL), AECOM will use the installation / construction date together with the ESL to determine the RSL. The asset inventory will be populated with data for each asset in terms of ESL and RSL. The RSL can be further refined by overlaying any information that the City deems pertinent to the non-core infrastructure defined in the scope of the project.

**Task 4.1.3: State of the Infrastructure Database and Report**

AECOM will prepare a preliminary MS Excel-based state of infrastructure database with dashboards dashboard for each service area upon completion asset inventory review and present to the City at the State of Infrastructure Workshop (see example in **Figure 4-2**). AECOM will address feedbacks from the workshop and prepare a final state of infrastructure dashboard. The initial asset list will be based primarily on output from the City’s spreadsheets and other sources provided by the City, which is utilized to build the final asset register. The asset inventory will be divided into the required categories and their sub-categories, as needed based on the asset class. Where gaps exist in the asset inventory, AECOM will work to source additional asset information from any available engineering studies, as-built drawings, and / or GIS data to improve the data quality.

Upon the submission of the MS Excel asset inventory, the City will be provided a minimum of two weeks to review the data and provide feedback. AECOM will incorporate the City’s comments and revise the datasets and include a State of Infrastructure section in the AMP report.

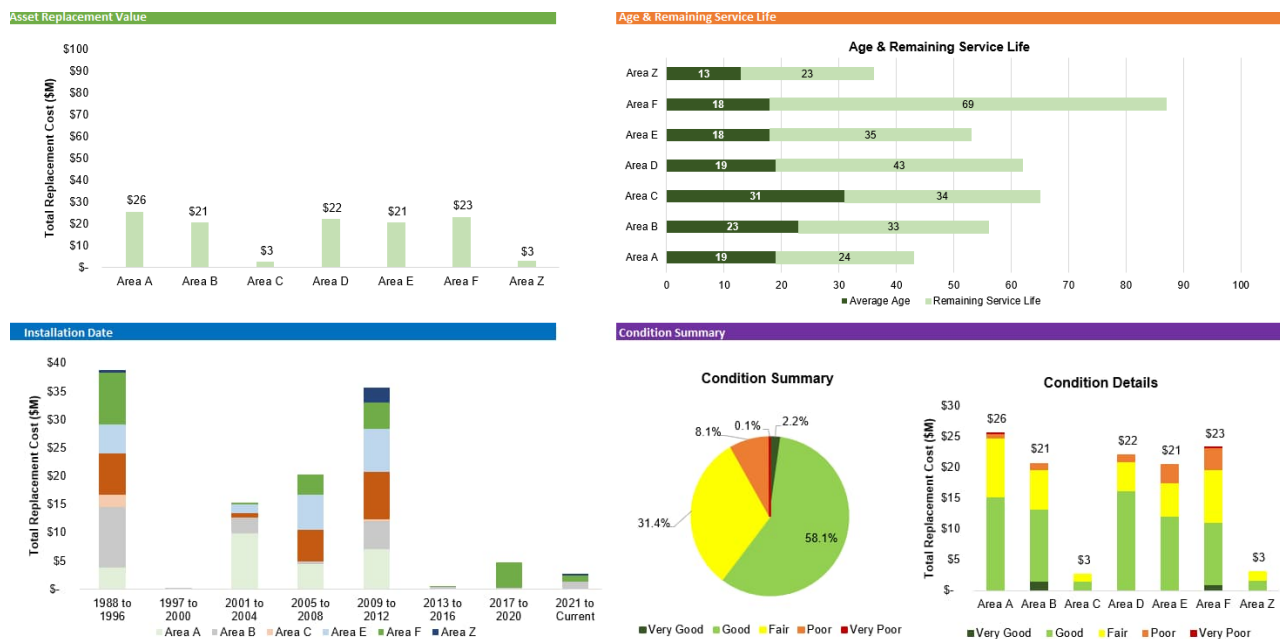

**Figure 4-2: Sample State of the Infrastructure Dashboard**

## Task 4.2: Levels of Service

### Task 4.2.1: Identify Stakeholders

An important first step in establishing LoS is to develop a list of internal and external stakeholders, along with their specific interests. These stakeholders essentially form the City’s customer base and will inform the development of the Customer Levels of Service (LoS).

Historically, only service recipients who pay for services would be considered customers; however, today customers can take many forms and should include any entity that has a legitimate interest in the service being provided. In addition to service recipients (i.e., the public), this may include:

- **Other Service Providers** – Stakeholders that require the municipal service / assets to provide their own services.
- **Regulatory Agencies** – Stakeholders that set standards, compliance regulations or other legislation that govern service delivery.
- **Neighboring Municipalities** – Other communities that are adjacent to the City and are affected by or have an interest in the City’s services.



Figure 4-3: Universal Service Values

Every stakeholder has certain interests in the service being provided and, in general, these interests can be categorized into the universal service values shown in Figure 4-3. Additional service values may be added, or the wording can be modified according to the City’s existing practices or wishes. While considering these service values, workshop participants will be asked to put themselves in the mind of each stakeholder to determine what they value most and what their specific interests are.

### Task 4.2.2: Develop LoS Framework

The next step is to align stakeholder interests with the City’s LoS performance measures and targets. LoS performance measures should be SMART (Specific, Measurable, Achievable, Realistic, and Time-bound). The LoS measures will provide a clear line of sight to AM by translating legislative requirements and corporate goals into specific and measurable performance indicators; in turn, guiding asset lifecycle activities, programs, and budgets. This is well illustrated by Figure 4-4.



Figure 4-4: Translating Strategic LoS Objectives into Performance Measures

Attributed to AECOM’s leadership in the Canadian Benchmarking Initiative (CIBI), our project team is uniquely positioned to support the City towards developing a comprehensive LoS framework. AECOM is intimately familiar with the data requirements, key performance indicators, collection strategies, and approach to measuring LoS performance across various assets. AECOM’s involvement with the CIBI will enable the City to draw on the collection of quality data, processes and information, and respective knowledge and best practices generated through the collaboration of the best minds of Canadian municipalities and utilities.

**Task 4.2.3: Demand Management**

The objective of this task will be to document all expected demand drivers, such as increased development, environmental regulations, climate change, and project future changes. In many cases, this has already been done through other studies. AECOM will utilize existing and available literature, such as the City’s OCP and related management plans and augment them where necessary based on our knowledge and experience from working on similar assignments with other municipalities within Ontario.

Next, the focus will shift towards documenting the anticipated impact of each demand driver, on each asset / asset category, as illustrated in **Figure 4-5**. The advantage of our LoS approach is that, because each LoS is linked to an asset / asset category, direct linkages can also be established between our demand forecast and how that forecast will impact LoS.

Once demands have been established, the last objective of this task will be to help the City manage those demands. Demand management is a critical component of managing LoS and this exercise will help the City determine effective strategies for dealing with demand drivers. Possible mitigation approaches for the City to consider are asset-based solutions (e.g., upgrading / substituting existing assets, providing new assets, etc.) or non asset-based solutions (e.g., altering design criteria, changing habits through education, providing service alternatives, etc.).

Demand Driver	Potential Impact on the City’s Service Delivery
Regulatory Changes	Regulatory requirements related to the 2050 Net Zero Policy are expected to impact many building components such as the HVAC systems.
Aging Infrastructure / Deferred Maintenance	The City uses the FCI to inform the capital plan for addressing aging or deteriorated facility infrastructure. The City’s current threshold is 25% to keep the building well maintained. If the FCI is more than 25%, the cost of operations will be higher, at which point the City will consider decommission or retiring the building. The City envisions this threshold to be 15% in the future to meet the LoS targets. Deferred maintenance is one of the most significant challenges that the City is currently facing.
Climate Change	The City has a goal to meet the 2050 Net Zero Policy, which requires increased costs to reach this objective, such as purchasing more indoor air filters. Furthermore, the City is tracking the carbon generation of new building construction in order to meet the City’s carbon reduction target in 2030.
Staff Availability	The City is currently outsourcing certain services which is more expensive over the long-term compared to an in-house sourced approach.
Financial Funding	The City’s facilities are funded for now, but in three to five years, there will be new budget requirements for the replacement of facility assets. Technological obsolescence is expected to contribute to an increase in funding needs as newer, and more expensive, technology replaces older ones. Facility assets are primarily replaced using the capital budget; however, a small number of assets can be replaced using the O&M budget.

**Figure 4-5: Example City of Vaughan Facility Assets Potential Future Demand Drivers**

**Task 4.3: Asset Lifecycle Strategies**

Asset lifecycle management focuses on the specific activities that should be undertaken during all phases of the asset lifecycle. Considering entire asset lifecycles can ensure that the City makes sound decisions that consider present and future service delivery needs.

The overarching goal of lifecycle management is to maximize the long-term benefits and services that our assets deliver while minimizing the associated costs and risks in the long run. Every asset has a lifecycle cost, which is the total cost of all the activities undertaken throughout its service life. Part of the purpose of the asset management planning process is to fully understand and predict the long-range financial requirements for the City’s infrastructure to facilitate planning and resource management in the most cost-effective manner possible.

**Figure 4-6** illustrates how costs typically accumulate over

SUCCESSFUL AM PROGRAMS AIM TO  
 ACHIEVE TARGETED SERVICE LEVELS  
 THROUGH CUSTOMER-BASED  
 DECISION MAKING



an asset's life. It is worth noting that the accumulation of the ongoing operations and maintenance, renewal & replacement and disposal costs is many multiples of the initial acquisition costs. As such, it is important to fully understand the entire lifecycle costs across an asset's entire life before proceeding with asset acquisition.

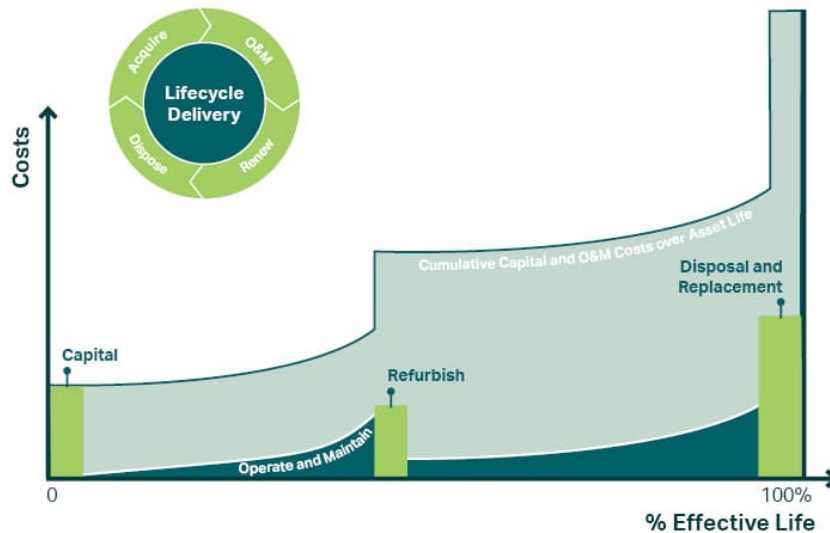

**Figure 4-6: Lifecycle Cost Accumulation Over Asset Life**

AECOM will evaluate, develop, and update asset lifecycle strategies, including acquisition, operations, maintenance, renewal, and disposal, to ensure the delivery of the desired LoS in a sustainable way. This includes identifying dependencies and scopes of work for key actions to maintain the current LoS over the 10-year planning period for the following lifecycle stages:

- **Acquisition:** New assets that did not previously exist. Required to meet increasing demand on infrastructure or enhanced levels of service.
- **Operations:** Regular activities to provide services such as cleaning and inspections. These have no direct influence on the health of an asset.
- **Maintenance:** Actions required to maintain the health of an asset and keep them in service.
- **Renewal:** Major capital work which restores, rehabilitates, replaces, or renews an existing asset to its original potential.
- **Disposal:** Any activity associated with the disposal of a decommissioned asset including sale, demolition, or relocation.

#### Task 4.4: Financial Strategies

AECOM will develop a comprehensive MS Excel financial model using the principles of Life Cycle Cost Analysis (LCCA) so that the City can prioritize and budget for an ongoing program that covers the upgrade, renewal / replacement of its core assets. This model will incorporate existing financial projections and be structured in such a manner to integrate with the City's broader financial plan. Following completion of the preceding Inventory, LoS, AECOM will use this information to inform the LCCA of the City's non-core infrastructure. The general approach proposed for this model is to incorporate all aspects of the AM Plan into the MS Excel model. As such, AECOM will employ our custom-built MS Excel Asset Management Investment Planning tool serve as the basis for this task, which will then be customized to the needs of the City. The benefit of using the MS Excel toolset is the ability to adjust input parameters "on the fly" in a workshop setting to determine the impact on overall funding needs and utility fees and rates / taxes. The

result will be an MS Excel-based financial model that predicts and prioritizes AM activities over a short-term and long-term funding projection window. Some of the key components and benefits of the MS Excel Financial Model are as follows:

- Contains all quantitative AM information for each AMP in a single source.
- Ability to calculate the present-day value of the assets and to forecast various future financial scenarios.
- Easy filtering / separation of various asset categories to allow subtotalling.
- Includes the separation of budget drivers (i.e., acquisition, renewal, O&M, disposal, etc.).
- Takes into consideration multiple replacements of the same asset within the study time horizon (i.e., if any assets have an expected life of less than 10 years).
- Ability to conduct sensitivity analysis on input factors such as inflation, unit costs or expected service lives.

This task will include a review of historical new capital, O&M, and capital expenditures information. AECOM will work with the City's Finance and Engineering staff to obtain past records of new capital, O&M, and capital replacement/ renewal costs to inform the financial projections generated under this task. Based on the information collected in the preceding tasks, AECOM will work with the City's Finance and Engineering to determine the best available estimates. AECOM will develop estimates for the following:

- Asset Renewal Funding Ratio, which estimates the percentage of total asset funds required for the optimal renewal and replacement of assets over the next 5, 10, and 20 years.
- 10-Year and 20-Year Financial Plan, which documents the projected expenditures for Operations and Maintenance, Capital Renewal / Replacement, Capital New / Expansion, and Disposals.
- **Figure 4-7** shows an example of funding gap identification results. AECOM will review the current expenditures and compare the proposed funding needs.
- Develop a funding strategy to address the funding gaps. AECOM will work with the City to identify how increasing revenue and source of budget can impact capital planning while acknowledging that choosing to reduce the level of service may also be available to manage affordability. Funding resources will be described, from which the City could benefit and alleviate some of the most significant gaps to maintain non-core infrastructure in an acceptable condition. Some potential funding source could include Development Cost Charges (DCCs), various grants, and utility rates.

City of Sault Ste. Marie  
 Professional Services - Non-Core Asset Management Plans

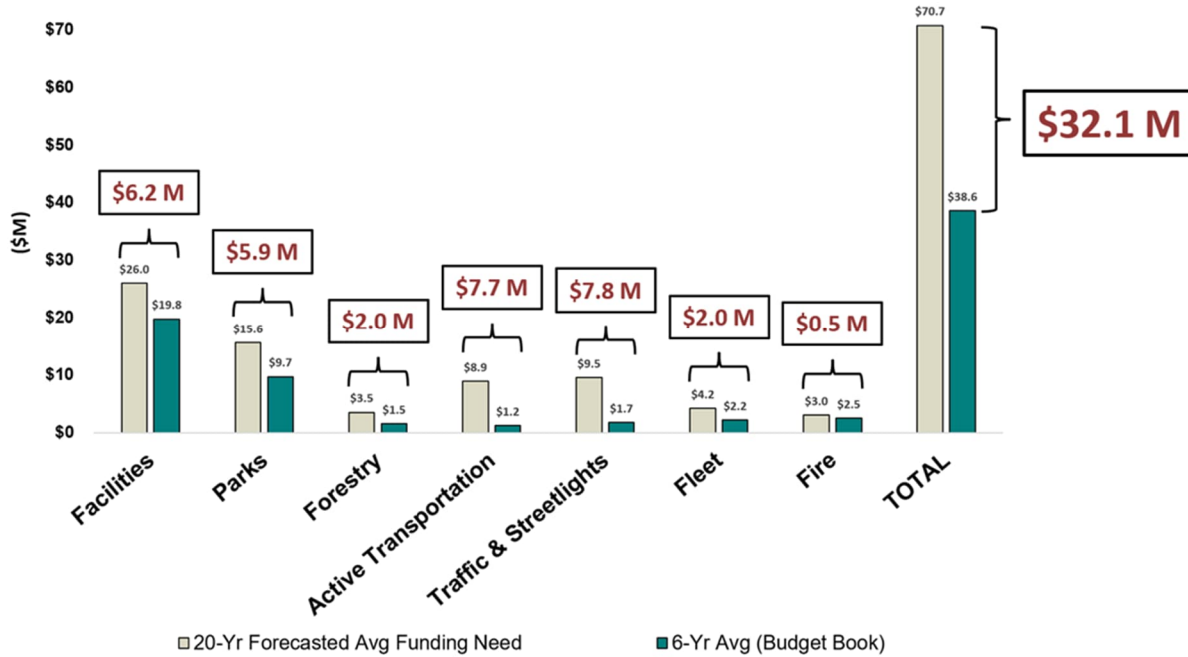

Figure 4-7: Non-Core Asset Funding Gap Analysis Sample

In this task, AECOM will develop the asset funding framework in an MS Excel spreadsheet to present to the City, where staff will have an opportunity to provide input and feedback. AECOM will ensure accurate reporting of the City’s annual average investment needs for non-core assets based on the consultation with the City staff. Figure 4-8 presents a sample of the typical graphical outputs from the proposed MS Excel Asset Financial Model.

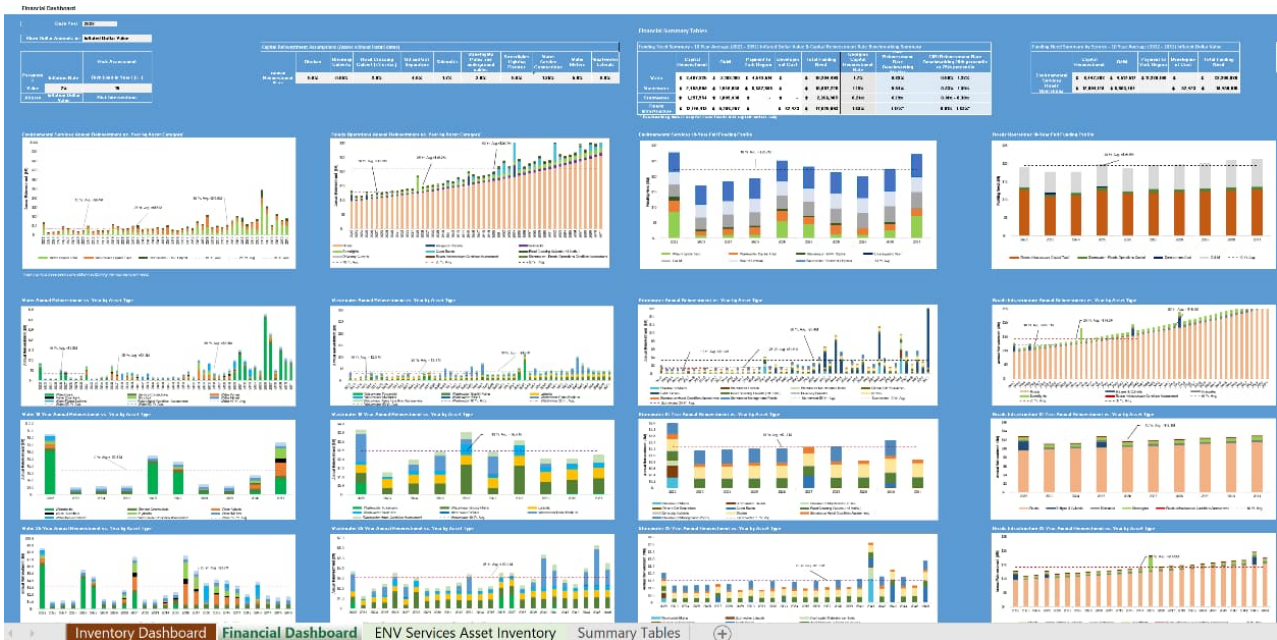

Figure 4-8: Sample outputs from the MS Excel Financial Dashboard

## Task 5: Draft & Final AM Plan

Finally, the results extracted from **Task 2** to **Task 4** will be compiled into seven AMP's for the respective non-core asset classes, as follows:

- Protection Services
- Solid Waste
- Parks & Cemetery
- Facilities
- Fleet
- Roadway Appurtenances
- Active Transportation

Understanding that there will be repetition within certain sections across individual AMP's, the outline of the AMP will be structured according to the following Table of Contents:

1. Executive Summary
2. Introduction
3. State of Infrastructure
4. Levels of Service
5. Future Demand
6. Lifecycle Management Plan
7. Financial Summary
8. Conclusions and Recommendations

AMPs may vary in length depending on the asset category.

Upon the submission of the draft AMP, the City will be provided a minimum of two weeks to review the AMP and provide feedback. AECOM will incorporate the City's comments and revise the AMP prior to the release of a final version. A final council presentation will be provided.

## 5. Project Schedule

Our Project Schedule (Gantt Chart) is presented in **Figure 5-1**. This Project Schedule provides a description of the major work tasks and associated time frames proposed for this assignment. While we believe this to be a viable schedule that meets the City's desired completion date, our project manager will develop and submit a formal detailed schedule during the Project Kick-off Meeting.

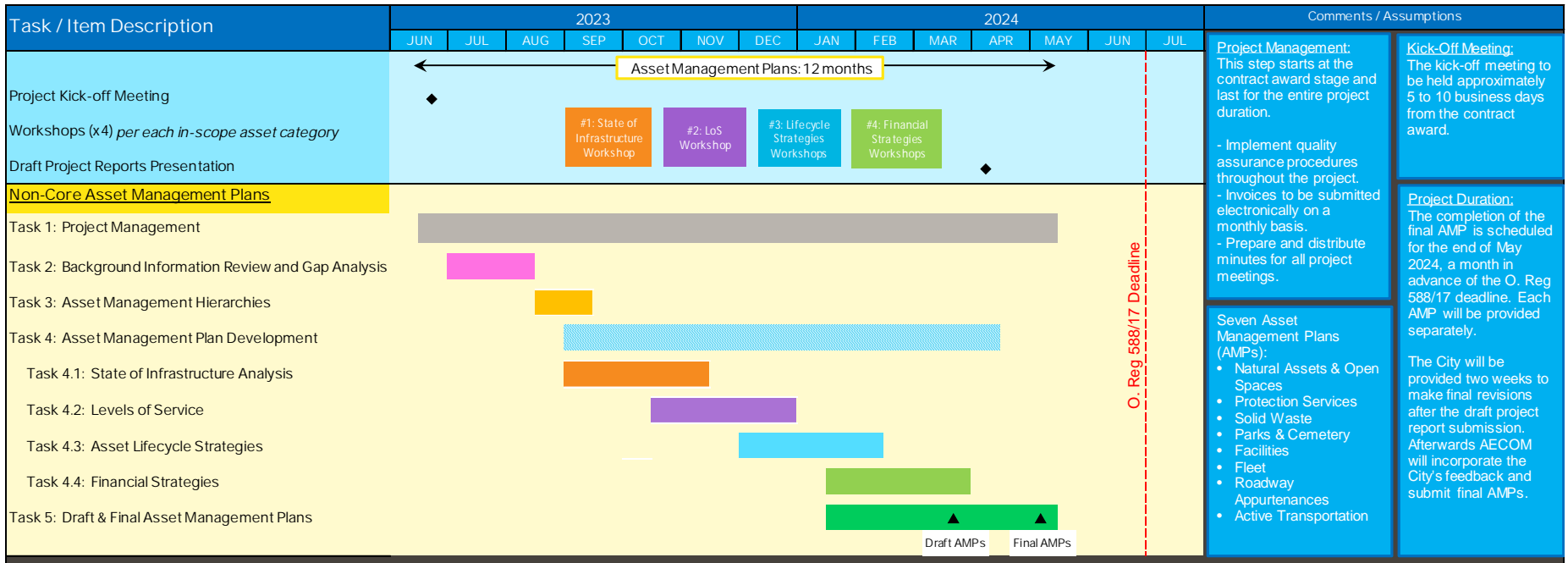

Figure 5-1: Project Schedule

## 6. Fees

This section details the assumptions made in our estimate of fees, rates, and charges for the proposed project. Our fee is contingent upon the following:

- The scope of work will be as outlined in the Work Plan / Methodology Section of our proposal.
- AECOM will perform all professional services in accordance with the standard of care customarily observed by professional consulting firms performing similar services at the same time and location. The standard of care will include adherence to all applicable published standards of the profession and laws, regulations, by-laws, building codes and governmental rules.
- AECOM confirms that the upset fee will not be exceeded unless the City specifically requests that new scope be attached to this assignment. The fee and disbursement totals shown for each task are based upon our best estimates. We reserve the right to adjust budgets for each task as necessary while remaining within the total maximum fee.
- All invoices will be rendered monthly, with net 30-day payment terms. Interest will be charged on overdue accounts at a rate of 2 percent per month. Individual tasks will be billed on a per lump sum basis. All invoices will be accompanied by a progress report outlining the following:
  - Project budget.
  - Current invoice.
  - Total invoiced to date.
  - Projected variances (if any).
  - Tasks completed in the current invoice period.
  - Tasks to be completed in the next period.
- General disbursement allowances are included within the fee-task table. All disbursement costs incurred during the assignment will be invoiced at the actual cost plus 5% for insurance, processing, and administration costs.
- The individual charge-out rates shown in the pricing table are valid until July 31<sup>st</sup>, 2024. Should the project continue beyond that date for reasons beyond AECOM's control, we reserve the right to increase the rates by an inflationary adjustment of 5%.
- Depending on the City's direction, this work could be performed as a scope extension to the existing Terms and Conditions of City of Sault Ste. Marie By-Law No. 2021-167 Asset Management Plan Consulting Engineering Services Engineering Agreement. Alternatively, AECOM and the City could enter into a new agreement for this scope of work using the Municipal Engineers Association (MEA) Client / Engineer Agreement for Professional Consulting Services.

Task descriptions and estimated level of effort are presented in our task-fee schedule presented in [Table 6-1](#).

Table 6-1: AECOM Pricing Proposal

Proposed Time-Task Breakdown City of Sault Ste. Marie Non-Core Asset Management Plans		Project Manager	Project Director / Local Liaison	Lead Verifier	QA/QC Lead	State of the Infrastructure Lead	Deputy Project Manager + Financial Strategy & Level of Service Lead	Lifecycle Management Strategy Lead	AM Technical Support	AM Technical Support	AM Technical Support	Support	Total Hours	Total Labour	Disbursements	TOTAL COST (Excl. HST)
		Chris Lombard	Rick Talvitie	Jeff Atherton	Bill Hart	Mohammad Amini	Donghui Lu	Nikita Bhalla	Lily Deng	Baitao Liang	Quincy Liu	Administrative Support				
No.	TASK DESCRIPTION															
1	Task 1: Project Management	40	4	1	2	2	2	2	2	2	2	1	60	\$12,560	\$100	\$12,660
2	Task 2: Background Information Review & Gap Analysis	8	2	1	12	16	16	16	16	16	16	1	120	\$15,080	\$65	\$15,145
3	Task 3: Asset Management Hierarchies	16	1	1	12	16	16	16	16	16	16	1	127	\$16,750	\$65	\$16,815
4	Task 4: Asset Management Plan Development	64	16	4	32	152	176	152	72	96	96	4	864	\$106,960	\$400	\$107,360
5	Task 4.1: State of Infrastructure Analysis	16	4	1	8	80	24	24	24	24	24	1	230	\$28,220	\$100	\$28,320
6	Task 4.2: Levels of Service	16	4	1	8	24	48	24	16	24	24	1	190	\$23,900	\$100	\$24,000
7	Task 4.3: Asset Lifecycle Strategies	16	4	1	8	24	24	80	16	24	24	1	222	\$27,420	\$100	\$27,520
8	Task 4.4: Financial Strategies	16	4	1	8	24	80	24	16	24	24	1	222	\$27,420	\$100	\$27,520
9	Task 5: Draft & Final Asset Management Plans	16	16	2	12	80	80	80	80	80	80	4	530	\$62,620	\$100	\$62,720
<b>Total Hours</b>		<b>144</b>	<b>39</b>	<b>9</b>	<b>70</b>	<b>266</b>	<b>290</b>	<b>266</b>	<b>186</b>	<b>210</b>	<b>210</b>	<b>11</b>	<b>1,701</b>			
																\$214,700
<b>Percent of Project Time</b>		<b>8%</b>	<b>2%</b>	<b>1%</b>	<b>4%</b>	<b>16%</b>	<b>17%</b>	<b>16%</b>	<b>11%</b>	<b>12%</b>	<b>12%</b>	<b>1%</b>				



Christiaan Lombard, MBA, P.Eng.

AECOM Canada Ltd.  
3292 Production Way, Suite 330  
Burnaby, BC



**The Corporation of the City of Sault Ste. Marie  
Procedure By-law 2023-100**

## Table of Contents

1. <i>Rules of Procedure Adopted</i> .....	8
<b>DUTIES OF THE MAYOR</b> .....	<b>8</b>
2. <i>Head of Council</i> .....	8
2.1 Mayor Presides .....	8
2.2 Right to Vote.....	8
2.3 State Facts and Position Without Leaving Chair .....	8
2.4 Information to Council Without Leaving Chair .....	8
2.5 Acting Mayor .....	9
2.6 Amendment to List of Acting Mayors.....	9
<b>MEETINGS OF COUNCIL</b> .....	<b>9</b>
3. <i>Inaugural Meeting</i> .....	9
3.1 Date.....	9
3.2 Seating of Members .....	9
4. <i>Regular Meetings</i> .....	10
4.1 Date and Time.....	10
4.2 Length of Meeting.....	10
4.3 Cancellation.....	10
4.4 Changing Date or Time .....	10
4.5 Notice .....	10
4.6 Place of Meeting.....	10
4.7 Commencement Proceedings .....	10
4.8 Quorum (City Council).....	10
4.9 Quorum Lacking – Adjourn.....	11
4.10 Meetings Open to Public.....	11
4.11 Electronic Recording.....	11
4.12 Declarations of Conflict of Interest.....	11
5. <i>Closed Session</i> .....	11
5.1 Municipal Act Provisions .....	11
5.2 Educational or Training Sessions.....	12
5.3 Resolution Authorizing Closed Session.....	12
5.4 Recording Closed Sessions .....	12
5.5 Voting.....	12
5.6 Closed Meeting Investigation .....	12
6. <i>Special Meetings</i> .....	12
6.1 Calling .....	13
6.2 Notice to Members of Council .....	13
6.3 Notice to the Public .....	13
6.4 Full Explanation in Notice.....	13
6.5 Emergency Meetings.....	13
<b>RULES OF CONDUCT AND DEBATE</b> .....	<b>13</b>
7. <i>Rules of Procedure</i> .....	13
7.1 Head of Council Presides.....	13

7.2	Address the Chair.....	13
7.3	Two Members Recognized.....	13
7.4	Disrespectful or Irrelevant Speech .....	14
7.5	Questions That Shall Not be Put .....	14
7.6	Points of Order .....	14
7.7	Rulings on Points of Order .....	14
7.8	Privilege, Point of Order – Members Called to Order – Appeal .....	14
7.9	Violation of Rules of Procedure .....	14
7.10	Member Called to Order .....	14
7.11	Appeal to Council – Privilege, Point of Order.....	14
7.12	On Appeal – Head of Council to Provide Reasons .....	14
7.13	Motions Out of Order .....	15
7.14	Conduct of Members .....	15
7.15	Member Who Persists In Breach .....	15
7.16	Question Read.....	15
7.17	Speak Once – Reply.....	15
7.18	Length of Speech.....	15
7.19	Close Debate .....	15
7.20	Member Leaving Chamber .....	15
7.21	Questions.....	16
7.22	Language.....	16
7.23	Expulsion from Meeting .....	16
7.24	Confidentiality .....	16

**RESOLUTIONS AND MOTIONS ..... 16**

8.	<i>Rules of Procedure</i> .....	16
8.1	Form.....	16
8.2	Withdrawal .....	16
8.3	Reading.....	16
8.4	No Debate Until Read .....	16
8.5	No Debate After Question Put.....	17
8.6	Notice of Motion .....	17
8.7	Finality of Vote.....	17
8.8	Relevancy of Debate .....	17
8.9	Order of Precedence .....	17
8.10	Presiding Officer to Determine if Motions are in Order .....	17
9.	<i>Motion to Amend</i> .....	17
9.1	Order of Precedence .....	17
9.2	Debatable.....	18
9.3	One Amendment Permitted at One Time .....	18
9.4	Notice of Amendment.....	18
9.5	Amendment to Amendment.....	18
9.6	Similar in Import .....	18
10.	<i>Motion to Refer</i> .....	18
10.1	Order of Precedence .....	18
10.2	Debate .....	18
10.3	Direction to Body Being Referred .....	18

11. <i>Motion to Postpone</i> .....	18
11.1 Must Include Reason.....	18
11.2 Debate.....	18
12. <i>Motion to Postpone Indefinitely</i> .....	18
12.1 Defined.....	19
12.2 Order of Precedence.....	19
12.3 Debate.....	19
13. <i>Motion to Postpone to a Certain Time</i> .....	19
13.1 Defined.....	19
13.2 Order of Precedence.....	19
13.3 Debate.....	19
14. <i>Motion to Postpone Temporarily</i> .....	19
14.1 Defined.....	19
14.2 Order of Precedence.....	19
15. <i>Postponement or Referral – When Introduced</i> .....	19
16. <i>Motion to Limit or Extend Debate</i> .....	19
16.1 Defined.....	19
16.2 Order of Precedence.....	19
16.3 Debate.....	20
16.4 Vote Required.....	20
17. <i>Motion to Close Debate</i> .....	20
17.1 Defined.....	20
17.2 Order of Precedence.....	20
17.3 Debate.....	20
17.4 Vote Required.....	20
18. <i>Motion to Raise a Question of Privilege</i> .....	20
18.1 Defined.....	20
18.2 Order of Precedence.....	20
18.3 Debate.....	20
18.4 Vote Required.....	20
19. <i>Motion to Recess</i> .....	20
19.1 Defined.....	20
19.2 Order of Precedence.....	21
19.3 Debate.....	21
20. <i>Motion to Adjourn</i> .....	21
20.1 Defined.....	21
20.2 Order of Precedence.....	21
20.3 Debate.....	21
20.4 When in Order.....	21
21. <i>Motion to Reconsider</i> .....	21
21.1 Defined.....	21
21.2 Debate.....	21
21.3 Who May Move – Subsequent Meeting.....	21
21.4 Notice of Motion Required.....	21

21.5	No Reconsideration of Amendment After Main Motion Disposed of .....	21
21.6	Order of Business .....	22
21.7	By-laws .....	22

**VOTING..... 22**

22.	<i>Recorded Votes</i> .....	22
22.1	Requested .....	22
22.2	Mandatory.....	22
22.3	Electronic Voting.....	22
22.4	Disagreement as to Result .....	22
22.5	All Members to Vote .....	22
22.6	Refusal to Vote .....	23
22.7	Severability of Question .....	23

**ORDER OF PROCEDURE..... 23**

23.	<i>Agenda</i> .....	23
23.1	Agenda Review Committee .....	23
23.2	Correspondence Agenda .....	23
23.3	Agenda .....	23
23.4	Deviation from Order of Business .....	24
23.5	Consent Agenda .....	24
23.6	Delivery of Agenda to Council.....	24
23.7	Release of Agenda to Public.....	24
23.8	Motions and By-laws on Agenda .....	24
23.9	Movers/Seconders .....	24
23.10	Addendum .....	25
24.	<i>Petitions</i> .....	25
25.	<i>Proclamations</i> .....	25
25.1	Requests.....	25
25.2	Approved Proclamations.....	25
26.	<i>Presentations</i> .....	26
26.1	Request in Writing .....	26
26.2	Review of Request.....	26
26.3	Appeal .....	26
26.4	Length of Presentation.....	26
27.	<i>Delegations</i> .....	26
27.1	Request in Writing .....	26
27.2	Where Public Meeting / Hearing .....	26
27.3	Agenda Review Committee May Decline.....	26
27.4	Appeal .....	27
27.5	Length of Delegation.....	27
27.6	Where More Than One Delegation on Same Matter.....	27
27.7	Dispute as to Whether Delegation is Supporting or Opposed.....	27
27.8	Re-Address.....	27
27.9	Opportunity to be Heard Where Notice Not Given .....	27
27.10	Statutory Public Meetings .....	27

27.11 Rules on Website.....	28
28. <i>By-laws</i> .....	28
28.1 Amending By-laws .....	28
28.2 Three Readings .....	28
28.3 Regulatory By-laws.....	28
<b>COMMITTEE OF THE WHOLE.....</b>	<b>28</b>
29. <i>Rules of Procedure</i> .....	28
29.1 Rules of Order .....	28
29.2 Questions of Order .....	28
29.3 Adjournment of Committee Proceedings .....	28
29.4 Chair Votes.....	29
29.5 Debate from Chair .....	29
29.6 Report of Committee of the Whole.....	29
<b>COMMITTEES.....</b>	<b>29</b>
30. <i>Rules Applying to all Committees</i> .....	29
30.1 Definition.....	29
30.2 Mayor Ex Officio .....	29
30.3 Quorum (Boards and Committees) .....	29
30.4 Notice .....	30
30.5 Secretary .....	30
30.6 Application of Legislation .....	30
30.7 Absence of Board or Committee Members.....	30
30.8 Refusal to Call Meetings, etc. ....	30
30.9 Chair Votes.....	30
30.10 Committee Appointments.....	30
30.11 Police Record Checks .....	32
31. <i>Special Committees</i> .....	32
31.1 Appointment.....	32
31.2 Jurisdiction.....	32
31.3 Chair.....	32
31.4 Membership.....	32
31.5 Meetings .....	32
31.6 Report in Writing.....	32
31.7 Confined to Matters Referred.....	32
31.8 Refusal to Give Due Attention.....	32
31.9 Dissolution .....	32
31.10 Attendance by Members of Council .....	32
<b>GENERAL PROVISIONS.....</b>	<b>32</b>
32. <i>General</i> .....	33
32.1 Standing Rules Suspended .....	33
32.2 Rules of Parliament .....	33
32.3 Addresses of Members of Council .....	33
32.4 Execution of Documents .....	33
32.5 Electronic Devices .....	33

32.6	Attendance in Council Chamber .....	33
32.7	Anonymous Communications .....	33
32.8	Administrative Corrections .....	33
32.9	Severability .....	33
32.10	Repeal .....	33
32.11	Effect .....	34



**THE CORPORATION OF THE CITY OF SAULT STE. MARIE  
BY-LAW 2023-100**

**COUNCIL PROCEDURE:** A by-law to regulate the proceedings of the Council of the City of Sault Ste. Marie

THE COUNCIL of the Corporation of the City of Sault Ste. Marie, pursuant to section 238 of the *Municipal Act, 2001*, and amendments thereto, ENACTS as follows:

**1. Rules of Procedure Adopted**

- 1.1 In all proceedings had or taken by Council the following rules and regulations shall be observed, and shall be the rules and regulations for the order and dispatch of business of the said Council.
- 1.2 This by-law shall apply to and govern the calling and proceedings of meetings of local boards and committees as defined in the *Municipal Act, 2001*, that is:
  - “committee” means any advisory or other committee, subcommittee or similar entity of which at least 50 per cent of the members are also members of Council or a local board;
  - “local board” does not include the police services board, public library board or conservation authority;
  - “meeting” means any regular, special or other meeting of Council, of a local board or of a committee where;
    - (a) a quorum of members is present, and
    - (b) members discuss or otherwise deal with any matter in a way that materially advances the business or decision-making of the Council, local board or committee.
- 1.3 The Procedure By-law shall be reviewed during the term of each Council by establishing a Procedure By-law Review task force initiated by the City Clerk.

**DUTIES OF THE MAYOR**

**2. Head of Council**

- 2.1 *Mayor Presides*

The Mayor, being the head of Council, shall preside at all meetings of Council and shall be addressed as Mayor or Acting Mayor as the case may be.
- 2.2 *Right to Vote*

The head of Council (except where the head of Council is disqualified to vote by reason of conflict of interest or otherwise) may vote with the other members on all questions. Any question on which there is an equality of votes shall be deemed to be defeated.
- 2.3 *State Facts and Position Without Leaving Chair*

The head of Council may state relevant facts and their position on any matter before Council and may debate the question before Council without leaving the Chair.
- 2.4 *Information to Council Without Leaving Chair*

The head of Council may, without leaving the Chair, address Council between proceedings on any matter which the head of Council deems pertinent to the business of the municipality.

### 2.5 *Acting Mayor*

At the first business meeting of Council in its term, a by-law shall be placed on the Agenda designating members of Council as Acting Mayor on a monthly rotational basis. Members of Council assume the duties of Acting Mayor on a rotational basis in the event that the Mayor:

- a) does not attend at a meeting within fifteen minutes after the time appointed for the meeting;
- b) has informed the City Clerk that they will be late to the meeting;
- c) is unable to chair the meeting or a portion thereof due to the provisions of the *Municipal Conflict of Interest Act*;
- d) cannot attend to the business duties of the position of Mayor due to illness or absence;
- e) refuses to act; or
- f) if the Mayor's office is vacant.

These provisions only extend to the Acting Mayor presiding at Council Meetings.

The rotation list shall be determined by lot drawn by the City Clerk.

### 2.6 *Amendment to List of Acting Mayors*

A motion to amend the rotation list of Acting Mayors may be made without notice upon the written consent of the Councillor directly concerned.

## **MEETINGS OF COUNCIL**

### **3. Inaugural Meeting**

#### 3.1 *Date*

The inaugural meeting of the newly elected Council following a regular election shall be held on (or as near as practicable after) the 15<sup>th</sup> day of November.

The City Clerk shall be responsible for the content of the Agenda of the inaugural meeting. The contents of the Agenda shall be as follows:

- a) Opening of the Meeting (opening ceremonies)
- b) Mayor's Declaration of Office and Oath of Allegiance
- c) Councillors' Declarations of Office and Oaths of Allegiance
- d) Mayor's Inaugural Address
- e) Councillors' Inaugural Addresses
- f) Adjournment

#### 3.2 *Seating of Members*

Prior to the inaugural or first business meeting of Council in each election year the order of seating of Council members shall be determined in the following manner. So long as members are elected from wards and the chamber is divided into two sides or rows, one

member from each ward shall be seated in each row or side. The member with the greatest seniority of continuous service shall be seated at the end of the row or side closest to the head of Council. Where seniority is equal, seating shall be determined alphabetically by last name. The order of seating shall remain in effect for the whole term.

#### **4. Regular Meetings**

##### **4.1 *Date and Time***

Regular meetings of Council shall be held at 5 p.m. on Mondays at approximately three week intervals. Where a Council meeting would fall on a holiday Monday, the meeting shall take place on the Tuesday following the holiday Monday.

##### **4.2 *Length of Meeting***

No meeting of Council shall exceed five (5) hours in length, including breaks, but excluding any portion of the meeting closed to the public. At the five (5) hour mark, the City Clerk shall call for a resolution to suspend the provisions of this by-law. Unless that resolution passes by a two-thirds vote of the members of Council present, Council shall adjourn the meeting.

##### **4.3 *Cancellation***

Despite the provisions of section 4.1, the head of Council may, after consulting with other members of the Agenda Review Committee, cancel a regular meeting of Council if, in their opinion, the items proposed for the Agenda are not of sufficient importance or urgency to warrant the holding of a meeting. Notice of such cancellation shall be posted to the City's website and distributed to the media electronically as soon as possible.

##### **4.4 *Changing Date or Time***

The Council may change the time or date or both of a regular meeting of Council by passing a resolution at a meeting preceding the proposed meeting. Notice of such cancellation shall be posted to the City's website and distributed to the media electronically as soon as possible.

##### **4.5 *Notice***

Notice of meetings of Council, local boards and committees will appear on the City's website.

##### **4.6 *Place of Meeting***

All open meetings of Council shall be held in the Council Chambers unless Council has by resolution appointed some other place.

###### **4.6.1 *Electronic Participation***

Open and closed meetings of Council (and its boards and committees) may take place physically or electronically or a hybrid of both. Members who participate in open or closed meetings electronically shall be counted for purposes of quorum. Electronic meetings of Council and its boards and committees shall be livestreamed for public viewing.

##### **4.7 *Commencement Proceedings***

As soon after the scheduled time of the meeting as there is a quorum present, the head of Council shall call the members present to order.

##### **4.8 *Quorum (City Council)***

Six members of City Council shall be necessary to form a quorum. No meeting shall be held or continue unless a quorum is present (except as provided for in the *Municipal Conflict of Interest Act*).

#### 4.9 *Quorum Lacking – Adjourn*

Unless a quorum is present within fifteen minutes after the time appointed for the meeting of Council, the Council shall stand adjourned either until the next regular scheduled meeting or until a special meeting is called to deal with the matters intended to be dealt with at the adjourned meeting. The City Clerk shall record the names of the members present at the expiration of the fifteen minute time limit in the Minutes.

#### 4.10 *Meetings Open to Public*

Meetings shall be open to the public and no person shall be excluded therefrom except for improper conduct. An electronic meeting is open to the public when it is livestreamed for public viewing.

#### 4.11 *Electronic Recording*

Any person may make an electronic recording of Council or committee meetings provided that the activity does not, in the opinion of the Chair, interfere with the proceedings or interfere with Council sanctioned recording of the meeting.

#### 4.12 *Declarations of Conflict of Interest*

Written declarations of a Conflict of Interest are required for open and closed meetings. A registry of the declarations shall be made available for public inspection.

### **5. Closed Session**

#### 5.1 *Municipal Act Provisions*

Notwithstanding the provisions of section 4.10 above, and pursuant to the provisions of the *Municipal Act, 2001*, a meeting or part of a meeting may be closed to the public if the subject matter being considered is:

- a) the security of the property of the municipality or local board;
- b) personal matters about an identifiable individual, including municipal or local board employees;
- c) a proposed or pending acquisition or disposition of land by the municipality or local board;
- d) labour relations or employee negotiations;
- e) litigation or potential litigation, including matters before administrative tribunals, affecting the municipality or local board;
- f) advice that is subject to solicitor-client privilege, including communications necessary for that purpose;
- g) a matter in respect of which a council, board, committee or other body may hold a closed meeting under another Act;
- h) information explicitly supplied in confidence to the municipality or local board by Canada, a province or territory or a Crown agency of any of them;
- i) a trade secret or scientific, technical, commercial financial or labour relations information, supplied in confidence to the municipality or local board, which, if disclosed, could reasonably be expected to prejudice significantly the competitive

- position or interfere significantly with the contractual or other negotiations of a person, group of persons, or organization;
- j) a trade secret or scientific, technical, commercial or financial information that belongs to the municipality or local board and has monetary value or potential monetary value; or
  - k) a position, plan, procedure, criteria or instruction to be applied to any negotiations carried on or to be carried on by or on behalf of the municipality or local board;
  - l) an ongoing investigation respecting the municipality, a local board or a municipally-controlled corporation by the Ombudsman appointed under the *Ombudsman Act*, an Ombudsman referred to in subsection 223.13(1) of this Act, or the investigator referred to in subsection 239.2 (being the section authorizing appointment of a closed meeting investigator).
  - m) A meeting shall be closed to the public if the subject matter relates to the consideration of a request under the *Municipal Freedom of Information and Protection of Privacy Act* if the Council, board, commission or other body is the head of an institution for the purposes of that Act.

### 5.2 *Educational or Training Sessions*

A meeting of Council or local board or committee may be closed to the public if the following conditions are both satisfied:

- a) the meeting is held for the purpose of educating or training the members; and
- b) at the meeting, no member discusses or otherwise deals with any matter in a way that materially advances the business or decision-making of the Council, local board or committee.

### 5.3 *Resolution Authorizing Closed Session*

Prior to a closed session being held, a resolution shall be passed in open session authorizing the closed session, citing the relevant section of the *Municipal Act 2001* as well as a general description of the matter to be discussed.

### 5.4 *Recording Closed Sessions*

Closed sessions of Council shall be recorded using digital audio-video recording technology. The City Clerk's department shall be responsible for the care and retention of the resulting City Council records. This provision is discretionary for local boards and committees of Council.

### 5.5 *Voting*

Voting is not permitted in a closed session unless the vote is for a procedural matter or for giving directions or instructions to officers, employees or persons retained by or under contract with the municipality.

### 5.6 *Closed Meeting Investigation*

Should a report be issued by a closed meeting investigator finding that a meeting or part of a meeting that was the subject of an investigation by that person appears to have been closed to the public contrary to section 239 of the *Municipal Act, 2001* or to this procedure by-law, Council must pass a resolution stating how it intends to address the report.

## 6. **Special Meetings**

## 6.1 *Calling*

A special meeting of Council may be called in one of the two following ways:

- a) the head of Council may at any time summon a special meeting; or
- b) upon receipt of a petition of the majority of the members of Council, the City Clerk shall summon a special meeting for the purpose and at the time and place mentioned in the petition.

## 6.2 *Notice to Members of Council*

Notice of special meetings setting forth the matter or matters to be considered shall be given to all members of Council either:

- a) by email or delivery to each member of Council at their home or place of business not less than six hours in advance of the time fixed for the meeting; or
- b) by such other manner as the head of Council shall direct.

## 6.3 *Notice to the Public*

Notice of special meetings shall be posted to the City's website and distributed to the media electronically as soon as possible.

## 6.4 *Full Explanation in Notice*

Council shall not consider or decide on any matter at a special meeting unless it has been fully explained in the notice calling the meeting. This provision may be waived upon consent of all of the members of Council present, which shall be recorded in the Minutes.

## 6.5 *Emergency Meetings*

On urgent and extraordinary occasions, with the verbal consent of two-thirds of the members of Council present, an emergency meeting may be held and in this case the notice provisions of subsection 6.2 and 6.3 do not apply.

# **RULES OF CONDUCT AND DEBATE**

## **7. Rules of Procedure**

### 7.1 *Head of Council Presides*

The head of Council shall preserve order and decorum, and decide questions of order, subject to an appeal to Council.

### 7.2 *Address the Chair*

Any member desiring to speak shall, when seated, so signify a desire by fully extending their arm until the attention of the head of Council has been received and, upon being recognized by the head of the Council, shall address the Chair. When a member is speaking, no other member shall hold discourse which may interrupt the member speaking nor interrupt them except to raise a point of order.

### 7.3 *Two Members Recognized*

When two or more members signify their intention to speak in accordance with section 7.2, the head of Council shall recognize the member who first signified an intention and shall note and next recognize other members who have so signified their intention in the order in which they have signified their intention. The decision of the head of Council is final.

7.4 *Disrespectful or Irrelevant Speech*

No charge shall be made involving the character or conduct or language of a member of Council unless such member is present to reply or unless due notice has been given to that member to be present to defend himself.

7.5 *Questions That Shall Not be Put*

A member shall not:

- a) put a question that contains epithets;
- b) put a question that publishes the names of persons, or contains statements not strictly necessary to render the question intelligible, or contains charges which the member who asks the question is not prepared to substantiate; or
- c) renew a question when it has been fully answered.

7.6 *Points of Order*

Whenever any point of order or matter of urgency arises it shall be immediately taken into consideration by the head of Council.

7.7 *Rulings on Points of Order*

When the head of Council is called upon to decide a point of order or procedure, the point shall be stated without unnecessary comment, and they shall state the rule or authority applicable to the case.

7.8 *Privilege, Point of Order – Members Called to Order – Appeal*

A member who desires to address Council upon a matter that concerns the rights or privileges of Council collectively, or of themselves as a member thereof, shall be permitted to raise such matter of privilege. A matter of privilege shall take precedence over other matters. While the head of Council is ruling on the point of privilege, no one shall be considered to be in possession of the floor.

7.9 *Violation of Rules of Procedure*

A member who desires to call attention to a violation of the rules of procedure shall ask leave of the head of Council to raise a point of order. When leave is granted, the member shall state the point of order with a concise explanation following which the member shall remain seated until the head of Council has decided the point of order. The speaker in possession of the floor when the point of order or privilege was raised shall have the right to the floor when debate resumes.

7.10 *Member Called to Order*

A member called to order by the head of Council shall not speak again without the permission of the head of Council unless to appeal the ruling of the head of Council.

7.11 *Appeal to Council – Privilege, Point of Order*

The decision of the head of Council on a matter of privilege or point of order shall be final, subject to an immediate appeal by a member of Council.

7.12 *On Appeal – Head of Council to Provide Reasons*

If the decision is appealed, the head of Council shall give concise reasons for their ruling and Council shall decide the question without debate. The decision of Council is final.

### 7.13 *Motions Out of Order*

Whenever the head of Council is of the opinion that any motion offered to Council is contrary to the provisions of this by-law, the head of Council shall advise the members thereof immediately and quote the rule or authority applicable. Argument or comment shall not be permitted. Unless the ruling of the Chair is appealed to Council the motion shall not be put.

### 7.14 *Conduct of Members*

A member shall not:

- a) disobey the provisions of this by-law or decision of the head of Council or Council on questions of order or practice or upon the interpretation of the rules of procedure; or
- b) breach parliamentary decorum.

### 7.15 *Member Who Persists In Breach*

A member who persists in a breach of the foregoing subsection, after having been called to order by the head of Council, shall leave their seat for the duration of the meeting, but in case of apology being made by the offender, they may, by resolution of Council, be permitted forthwith to resume their seat.

### 7.16 *Question Read*

Any member may require the question under discussion to be re-read for clarification at any time during debate but not so as to interrupt a member while speaking.

### 7.17 *Speak Once – Reply*

A member shall not speak more than once on a matter without leave of Council except:

- a) in explanation of a material part of the speech which may have been misunderstood; or
- b) in reply after everyone else wishing to speak has spoken, provided that member is the mover or seconder of the motion.

### 7.18 *Length of Speech*

No member shall, without leave of Council, speak to any question, or in reply, for longer than five minutes.

### 7.19 *Close Debate*

A motion to close debate takes precedence over any amendment or debate of the motion to which it applies. Debate ceases until the motion to close debate is decided.

### 7.20 *Member Leaving Chamber*

In the event that a member intends to leave the Chamber and not return, prior to adjournment of a meeting, where practicable, they shall so state (including the time at which the member expects to leave) at the beginning of the meeting, or as soon as they become aware of the fact.

The City Clerk shall record such statement in the minutes of the meeting.



### 7.21 *Questions*

When questions are called for on the Agenda, or a specific item is under discussion, inquiries may be made of the head of Council, or through the head of Council to any Council member or staff person concerning any related matter connected with the business of the City, but no argument or opinion is to be offered, or facts stated, except as may be necessary to provide an explanation. Likewise, in answering any such question a member is not to debate the matter.

### 7.22 *Language*

No member shall use offensive words or unparliamentary language.

### 7.23 *Expulsion from Meeting*

The head of Council may expel or exclude from any meeting any person who has been guilty of improper conduct at the meeting.

### 7.24 *Confidentiality*

A member shall not disclose or release by any means to any member of the public any confidential information acquired by virtue of their office in either oral or written form, except when required by law or authorized by Council to do so.

Where a matter has been discussed in closed session and where the matter remains confidential, a member shall not disclose the content of the matter or the substance of the deliberations of the closed session.

Electronic closed sessions are confidential and no one other than the member should be able to hear the discussion.

A violation of this section of the procedure by-law is a breach of the Code of Conduct for Council and Local Boards.

## **RESOLUTIONS AND MOTIONS**

### **8. Rules of Procedure**

#### 8.1 *Form*

All motions and resolutions shall be in writing. The operative clause shall commence with the words "Resolved that", and shall be moved and seconded.

#### 8.2 *Withdrawal*

After a motion is read by the City Clerk, it shall be deemed to be in possession of Council, and it may only be withdrawn before decision or amendment with the permission of a majority of the members of Council present. Such motion, if read, shall appear in the Council Minutes.

#### 8.3 *Reading*

Every motion, once seconded, shall be received and read by the City Clerk except in the cases provided for by the rules of procedure, provided; however, that in motions that have been distributed with or printed in the Agenda, recitals need not be read.

#### 8.4 *No Debate Until Read*

No member shall speak to any motion until it is first read by the City Clerk. The mover is entitled to speak both first and last thereon if the member so elects.

8.5 *No Debate After Question Put*

After any question is finally put by the head of Council or other presiding officer, no member shall speak to the question, nor shall any other motion be made until after the result is declared. The decision of the head of Council or other presiding officer as to whether the question has been finally put shall be conclusive. When any decision is called for, members shall remain in their respective seats until the head of Council or other presiding officer has declared the result of the vote.

8.6 *Notice of Motion*

A member who wishes to introduce a motion, either on the Agenda or at the regular meeting, that is of a substantive nature must introduce the motion as a Notice of Motion.

The member who hands a written Notice of Motion to the City Clerk to be read at any regular Council meeting need not necessarily be seated during the reading of said notice.

8.7 *Finality of Vote*

Subject to a motion to reconsider, a motion once decided by Council may not be introduced again for twelve months; nor shall a motion that has been defeated be introduced as an amendment.

8.8 *Relevancy of Debate*

On all motions, discussion must be relevant to the subject under consideration.

8.9 *Order of Precedence*

The following is the order of precedence for motions from lowest to highest:

- a) Main motion
- b) Postpone Indefinitely
- c) Amend
- d) Refer
- e) Postpone to a Certain Time
- f) Limit or Extend Debate
- g) Close Debate
- h) Postpone Temporarily
- i) Raise a Question of Privilege – Individual
- j) Raise a Question of Privilege – Assembly
- k) Recess
- l) Adjourn (after time set to conclude a meeting)
- m) Fix the Time for a Continued Meeting

8.10 *Presiding Officer to Determine if Motions are in Order*

It shall be the duty of the head of Council or other presiding officer to determine what motions or amendments are in order (subject to an appeal to Council) and decline to put any motion before Council which the head of Council or other presiding officer deems to be clearly out of order or contrary to law.

**9. Motion to Amend**

9.1 *Order of Precedence*

A motion to amend takes precedence over a motion to postpone indefinitely or a main motion.

9.2 *Debatable*

A motion to amend is debatable.

9.3 *One Amendment Permitted at One Time*

Not more than one amendment to the main motion, nor more than one amendment to an amendment shall be permitted at one time.

9.4 *Notice of Amendment*

It shall not be necessary to give notice of intention to move an amendment but an amendment may be moved only when the motion it is sought to amend is before Council.

9.5 *Amendment to Amendment*

In case of an amendment to an amendment, the amendment to the main motion cannot be withdrawn until the amendment to the amendment has been withdrawn, defeated or carried.

9.6 *Similar in Import*

An amendment must be similar in import to the question which it is proposed to amend, but with sufficient variance to constitute a new question.

**10. Motion to Refer**

10.1 *Order of Precedence*

A motion to refer takes precedence over a motion to amend, a motion to postpone indefinitely, or a main motion.

10.2 *Debate*

A motion to refer is only debatable as to reasons for referral.

10.3 *Direction to Body Being Referred*

A motion to refer shall include direction as to the body or official to which it is being referred.

**11. Motion to Postpone**

11.1 *Must Include Reason*

A motion to postpone must include a reason for the postponement.

11.2 *Debate*

A motion to postpone is not debatable except:

- a) that the mover of the motion shall be entitled to give a brief explanation of the mover's reasons for postponement; and
- b) either the mover or the seconder of the motion which is the subject of the motion to postpone may speak against the motion to postpone;

One member of Council may speak for or against the postponement and shall be limited to two minutes.

**12. Motion to Postpone Indefinitely**

12.1 *Defined*

A motion to postpone indefinitely delays a decision to an indeterminate time beyond the current meeting.

12.2 *Order of Precedence*

A motion to postpone indefinitely takes precedence over a main motion.

12.3 *Debate*

Debate on a motion to postpone indefinitely may only go into reasons why the motion should or should not be dealt with at the time. It may go into the merits of the underlying main motion but only in respect to delaying the decision.

**13. Motion to Postpone to a Certain Time**

13.1 *Defined*

A motion to postpone to a certain time shall state a date that is within three months of the motion to postpone. A postponement to a certain time beyond three months should be a motion to refer.

13.2 *Order of Precedence*

A motion to postpone to a certain time takes precedence over: a motion to refer; a motion to amend; a motion to postpone indefinitely; or a main motion.

13.3 *Debate*

Debate on a motion to postpone to a certain time may only go into reasons why the motion should or should not be postponed. It may go into the merits of the underlying main motion but only in respect to postponing a decision.

**14. Motion to Postpone Temporarily**

14.1 *Defined*

A motion to postpone temporarily sets aside a motion for a short period of time, but no later than the end of the meeting. A motion that has been postponed temporarily may be taken up again through a motion to resume consideration.

14.2 *Order of Precedence*

A motion to postpone temporarily takes precedence over: a motion to close debate; a motion to limit or extend debate; a motion to postpone to a certain time; a motion to refer; a motion to amend; a motion to postpone indefinitely; or a main motion.

**15. Postponement or Referral – When Introduced**

Notwithstanding any other provision of this by-law, a motion to postpone or refer a matter under consideration may only be read prior to the commencement of debate or at the completion of the debate.

**16. Motion to Limit or Extend Debate**

16.1 *Defined*

A motion to limit or extend debate restricts or extends debate in some manner, such as by time or by number of speakers.

16.2 *Order of Precedence*

A motion to limit or extend debate takes precedence over: a motion to postpone to a certain time; a motion to refer; a motion to amend; a motion to postpone indefinitely; or a main motion.

### 16.3 *Debate*

Debate on a motion to limit or extend debate is restricted to the form of limitation or extension of debate.

### 16.4 *Vote Required*

Because a motion to limit or extend debate affects the rights of members of an assembly, a two-thirds vote of the members of Council present is required to pass.

## **17. Motion to Close Debate**

### 17.1 *Defined*

A motion to close debate stops all debate on a pending motion or series of consecutive pending motions and calls for an immediate vote.

### 17.2 *Order of Precedence*

A motion to close debate takes precedence over all debatable motions.

### 17.3 *Debate*

A motion to close debate is not debatable.

### 17.4 *Vote Required*

Because a motion to close debate affects the rights of members of an assembly, a two-thirds vote of the members of Council present is required to pass.

## **18. Motion to Raise a Question of Privilege**

### 18.1 *Defined*

A motion to raise a question of privilege can apply to either the assembly or to an individual.

### 18.2 *Order of Precedence*

A motion to raise a question of privilege takes precedence over the pending business and yields only to a motion to recess, a privileged motion to adjourn, or a motion to fix the time for a continued meeting. Raising a question of privilege affecting the meeting takes precedence over one affecting the individual.

### 18.3 *Debate*

The raising of a question of privilege is not debatable.

### 18.4 *Vote Required*

The raising of a question of privilege is ruled on by the head of Council or presiding officer.

## **19. Motion to Recess**

### 19.1 *Defined*

If a motion to recess is made while other motions are pending, the recess, if adopted, must take place immediately. If the motion is made when no other motion is pending, it may be used to set the time for a future recess.

### 19.2 *Order of Precedence*

A motion to recess takes precedence over all motions except the privileged motion to adjourn or to fix the time for a continued meeting.

### 19.3 *Debate*

Debate on a motion to recess is restricted to the length of time of the recess or to the time set for re-assembly or the time set for a future recess.

## **20. Motion to Adjourn**

### 20.1 *Defined*

The purpose of the motion to adjourn is to conclude the meeting. The motion to adjourn is always privileged when made after the time set to conclude the meeting. If made before the time set to conclude, it is made only as a main motion.

### 20.2 *Order of Precedence*

The privileged motion to adjourn takes precedence over all motions except a motion to fix the time for a continued meeting.

### 20.3 *Debate*

The privileged motion to adjourn is not debatable.

### 20.4 *When in Order*

A motion to adjourn shall be out of order:

- a) when a member is in possession of the floor; or
- b) when it has been decided that the vote be now taken; or
- c) during the taking of a vote.

## **21. Motion to Reconsider**

### 21.1 *Defined*

After a motion has been decided upon and at the same meeting any member who voted with the prevailing side may, in writing, move for reconsideration.

### 21.2 *Debate*

Debate on a motion to reconsider must be confined to reasons for or against reconsideration.

### 21.3 *Who May Move – Subsequent Meeting*

If a motion for reconsideration is moved and seconded at a subsequent meeting it shall be so moved by a member who voted with the prevailing side and shall be seconded either by a member who voted on the prevailing side or by a member who was absent at the time the matter proposed for reconsideration was originally voted on.

### 21.4 *Notice of Motion Required*

A motion to reconsider shall be preceded by a Notice of Motion.

### 21.5 *No Reconsideration of Amendment After Main Motion Disposed of*

A motion to reconsider an amendment after the original motion to which the amendment was proposed has been considered and disposed of is out of order.

### 21.6 *Order of Business*

If a motion to reconsider is decided in the affirmative, such reconsideration shall become the next order of business unless the motion calls for a future definite date. Debate on the question to be reconsidered may proceed as though it had never previously been voted on.

### 21.7 *By-laws*

When a by-law has been defeated at any stage of the order of procedure it shall be subject to a motion to reconsider and the foregoing rules shall apply thereto.

## **VOTING**

### **22. Recorded Votes**

#### 22.1 *Requested*

If a member present at a meeting at the time of a vote requests immediately before or after the taking of the vote that the vote be recorded, each member present, except a member who is disqualified from voting by any Act, shall announce their vote openly and the City Clerk shall record each vote.

#### 22.2 *Mandatory*

Any vote on a resolution or by-law which is required to be passed by a majority greater than a simple majority of the members of the Council shall be recorded.

#### 22.3 *Electronic Voting*

When the City Clerk opens the vote every member of Council present shall vote electronically unless they have declared a conflict of interest. The electronic vote is the official vote. The result of an electronic recorded vote will be read orally.

Exception: Voting on the following Agenda items may take place by show of hands:

2. Adoption of Minutes
5. Approve Agenda
7. Communications and Routine Reports of City Departments, Boards and Committees – Consent Agenda
- 8.8 Appointments to Boards and Committees
12. Consideration and Passing of By-laws (on consent)
14. Closed Session
15. Adjournment

#### 22.4 *Disagreement as to Result*

Any member who disagrees with the announcement made by the head of Council of the result of the vote shall immediately object to the head of Council's declaration and the vote shall be retaken by the City Clerk.

#### 22.5 *All Members to Vote*

Every member present when a question is put on a recorded vote shall vote thereon.

## 22.6 *Refusal to Vote*

Any member who refuses to vote on a recorded vote shall be recorded as voting in the negative.

## 22.7 *Severability of Question*

When the question under consideration contains distinct propositions, upon the request of any member the vote upon each proposition may be taken separately.

# ORDER OF PROCEDURE

## 23. Agenda

### 23.1 *Agenda Review Committee*

An Agenda Review Committee composed of the head of Council, Chief Administrative Officer and the City Clerk shall be charged with the responsibility of deciding the subject matters and items to appear on the Council Agenda, as well as any presentations and delegations to be heard by Council.

### 23.2 *Correspondence Agenda*

Correspondence Agendas are published as necessary containing general correspondence. If, after having received an item on the correspondence Agenda, a Council member wishes the matter placed on a regular Agenda they may make that request to the Agenda Review Committee.

Correspondence Agendas are to be published on the City website.

### 23.3 *Agenda*

The City Clerk shall prepare a Council Agenda in the following form and order:

1. Land Acknowledgement
2. Adoption of Minutes
3. Questions and information Arising Out of Minutes and Not Otherwise on Agenda
4. Declaration of Pecuniary Interest
5. Approve Agenda as presented (and any Addenda)
6. Presentations

#### PART ONE – CONSENT

7. Communications and Routine Reports of City Departments; Boards and Committees

#### PART TWO – REGULAR

8. Reports of City Departments; Boards and Committees
9. Unfinished Business, Notices of Motion and Resolutions Placed on Agenda by Members of Council
10. Committee of the Whole for the purpose of such matters as are referred to it by Council by resolution
11. Adoption of Report of the Committee of the Whole, if any
12. Consideration and passing of By-laws (Consent)
13. Questions By, New Business From, or Addresses by Members of Council Concerning Matters not Otherwise on Agenda
14. Closed session (if applicable)
15. Adjournment



This format applies to Council Agendas. It is not intended to apply to Agendas of boards and committees of Council.

**23.4 *Deviation from Order of Business***

The business of Council shall be considered in the order set forth on the Agenda, provided however, that the head of Council may vary the order of business to better deal with matters before the Council if the circumstances make it advisable to so vary the order.

Notwithstanding the above, planning applications shall be heard at 5 p.m. following Approve Agenda as presented (and any Addenda).

**23.5 *Consent Agenda***

The City Clerk shall prepare one motion to approve all items on a Consent section of the Agenda. Prior to voting on the motion, members may ask questions regarding any item on a Consent section of the Agenda. Any member who wishes to debate and have a separate vote on an item on a Consent section of the Agenda shall advise the head of Council, following which the item shall be excepted from the Consent motion; the Consent motion voted on; and the excepted item voted on separately.

**23.6 *Delivery of Agenda to Council***

On the Wednesday preceding each regular meeting of the Council, the City Clerk shall cause to be delivered to each member of Council electronically a full Agenda package.

**23.7 *Release of Agenda to Public***

The Council Agenda shall be released to the public no later than the end of business day on the Thursday preceding each regular meeting of Council.

**23.8 *Motions and By-laws on Agenda***

The City Clerk, with the assistance of other City officials, shall be responsible for the proper presentation of motions and by-laws to the Council.

**23.9 *Movers/Seconders***

Before the Agenda is prepared the City Clerk shall assign to each motion or by-law a mover and seconder to expedite the consideration of such matters by Council, provided any such designation shall be shown on the Agenda, subject to the discretion of the City Clerk, based on the following formula:

Month of Meeting	Mover shall be one of the members from:	Seconder shall be one of the members from:
January	Ward 1	Ward 5
February	Ward 2	Ward 4
March	Ward 3	Ward 1
April	Ward 5	Ward 2
May	Ward 4	Ward 3
June	Ward 1	Ward 5
July	Ward 2	Ward 4
August	Ward 3	Ward 1

September	Ward 5	Ward 2
October	Ward 4	Ward 3
November	Ward 2	Ward 5
December	Ward 3	Ward 1

The use of the above formula by the City Clerk is subject to the following exceptions:

- a) Any person so assigned as mover or seconder may notify the City Clerk that they do not wish to move or second such motion or by-law and the City Clerk shall then remove such name and attempt to find an alternate member who is willing to so act.
- b) A member may ask to be shown as mover or seconder of any matter expected to come before the Council.

#### 23.10 *Addendum*

The City Clerk may prepare an Addendum to the Agenda to deal with urgent matters or to provide supplementary information to items of business listed on the Agenda.

### 24. **Petitions**

The following requirements apply to every petition submitted to Council:

- a) The petition must be addressed to Council and request a particular action within the authority of Council;
- b) The petition must be legible, typewritten or printed in ink;
- c) The petition must be appropriate and not contain improper language;
- d) The petition shall state that signatories should be aware that their personal information will be shared publicly;
- e) Each signatory must print and sign their own name. A paper petition must contain original signatures only, written directly on the petition; and
- f) For electronic submissions, each signatory must provide their name, address, and a valid email address.

The City Clerk shall list petitions that comply with this section on the Correspondence Agenda.

A member of Council may request that a petition appearing on a Correspondence Agenda be placed on a Regular Council Agenda where the member of Council then may be permitted three minutes to present the petition and may move that it be referred to staff for a report to Council. A seconder is required.

The subject matter of a petition may not be debated.

### 25. **Proclamations**

#### 25.1 *Requests*

An organization or community group may request a Proclamation from the Mayor through the office of the Mayor.

#### 25.2 *Approved Proclamations*

If approved by the Mayor, proclamations will be made by the Mayor and communicated by the Mayor's office through various media.

## **26. Presentations**

### *26.1 Request in Writing*

An organization or community group wishing to appear before Council to make a presentation on items relevant to the business of Council must make the request in writing to the City Clerk giving details of the matter to be spoken to at least one week prior to the Council meeting.

### *26.2 Review of Request*

The request is decided by the Agenda Review Committee. The City Clerk will advise the presenter of the Agenda Review Committee's decision. If approved, the presentation will be listed on the Council Agenda.

### *26.3 Appeal*

If a person is not permitted to appear before Council by the Agenda Review Committee, that person may appeal to members of Council to consider the matter. Such a request should be made in writing to the City Clerk indicating the subject matter of the presentation by noon on the day of the Council meeting, including any presentation materials.

The request will be forwarded to members of Council by the City Clerk. If a motion is made, seconded and confirmed by majority vote to hear the delegation, the person may be permitted to address Council.

### *26.4 Length of Presentation*

The maximum length of time for a presentation to Council is three minutes.

## **27. Delegations**

### *27.1 Request in Writing*

Any person may, either on their own behalf or as a representative of an organization or group, request to appear at an open meeting of Council with respect to any item on the Agenda for that meeting except Agenda item 6 (Presentations) or reports for the information of Council.

Such a request must be made to the City Clerk before 11 a.m. on the day of the Council meeting.

Written submissions received by the City Clerk regarding an item on the Agenda may be added by way of Addendum to the Agenda.

### *27.2 Where Public Meeting / Hearing*

A request to make a delegation may be declined where there has been or will be at least one public meeting at which the public has been provided the opportunity to make representations.

### *27.3 Agenda Review Committee May Decline*

The Agenda Review Committee may, upon review of proposed delegation materials, decline a request to present if the material is deemed defamatory, inappropriate or outside the jurisdiction of Council.

#### 27.4 *Appeal*

If a person is not permitted to appear before Council by the Agenda Review Committee, that person may appeal to members of Council to consider the matter. Such a request should be made in writing to the City Clerk by 3 p.m. on the day of the Council meeting.

The request will be forwarded to members of Council by the City Clerk. If a motion is made, seconded and confirmed by majority vote to hear the delegation, the person may be permitted to address Council.

#### 27.5 *Length of Delegation*

The maximum length of time for a delegation to Council is three minutes.

#### 27.6 *Where More Than One Delegation on Same Matter*

When a matter is being considered concerning which one or more persons or delegations are addressing Council, the following procedure shall be adhered to:

- a) Explanation of matter in question by head of the Council.
- b) Address to Council by delegation(s) supporting action taken by Council, or action which the Council has been asked to take.
- c) Questions by members of Council to such delegation(s) for purposes of information only.
- d) Address to Council by delegation(s) opposing such action.
- e) Question by members of Council to such delegation(s) for purposes of information only.
- f) Reply by delegation(s) referred to in item b above.
- g) Questions by members of Council to any delegation or official for purposes of information only.
- h) Regular debate.
- i) Putting of question and vote.

The head of Council may permit deviations from the rules of procedure set forth above where in their opinion it is in the interests of the better consideration of the matter so to do.

#### 27.7 *Dispute as to Whether Delegation is Supporting or Opposed*

Any dispute as to whether a delegation or person comes within subclause b) or subclause d) of subsection 27.6 shall be determined by the head of Council, whose decision is final.

#### 27.8 *Re-Address*

If a speaker for any delegation referred to in the above requests an opportunity to re-address Council the speaker may, with the approval of the head of Council address Council on the matters already raised. Such re-address shall be limited to two minutes.

#### 27.9 *Opportunity to be Heard Where Notice Not Given*

Notwithstanding the failure of any person, persons or delegation to give the notice required under subsection 27.1 and 27.4 hereof, Council may hear any person or persons or delegation without notice upon a motion to suspend the rules of procedure passed by two-thirds of the members present.

#### 27.10 *Statutory Public Meetings*

Procedures regarding delegations are not intended to apply to statutory public meetings (e.g. *Planning Act*)

#### 27.11 *Rules on Website*

The rules for a person or a delegation wishing to appear before Council shall be posted on the municipal website.

### **28. By-laws**

#### 28.1 *Amending By-laws*

An amendment to a by-law must strictly relate to the subject matter of the by-law.

#### 28.2 *Three Readings*

Every by-law shall receive three readings before it is finally passed, which three readings may be given at one meeting. It is permissible on a motion for the final passing of a by-law to move that the third reading be postponed indefinitely or be postponed to a certain time.

#### 28.3 *Regulatory By-laws*

Prior to adoption of a regulatory by-law, public consultation shall be required by providing public notice of intention to pass the by-law.

### **COMMITTEE OF THE WHOLE**

### **29. Rules of Procedure**

#### 29.1 *Rules of Order*

The rules of procedure shall be observed in Committee of the Whole, so far as may be applicable, except that:

- a) Each motion shall be written and moved, but no motion shall require a seconder;
- b) Motions relating to the matter under consideration shall be put in the order in which they are proposed;
- c) No vote shall be recorded;
- d) There shall be no motion for the previous question;
- e) No motion for adjournment is allowed;
- f) No member shall speak longer than five minutes on any one question;
- g) In taking the yeas and nays, the names of the members shall not be recorded, nor shall the number of times speaking on any question be limited.

#### 29.2 *Questions of Order*

Questions of order arising in Committee of the Whole shall be decided by the Chair, subject to an appeal to the whole Committee. If no such appeal is made the decision of the Chair shall be final.

#### 29.3 *Adjournment of Committee Proceedings*

On motion in Committee of the Whole to rise and report, the question shall be decided without debate.

- a) No Action Be Taken

A motion in Committee of the Whole that "no action be taken" shall always be in order and shall take precedence over any other motion. No debate shall be allowed on a motion that no action be taken. On an affirmative vote, the subject referred to the Committee shall be considered as disposed of in the negative.

b) Rise Without Reporting

Subject to subsection a) above, a motion in Committee of the Whole to rise without reporting shall always be in order and shall take precedence over any other motion. No debate shall be allowed on a motion to rise without reporting but no member shall speak more than once. On an affirmative vote the subject referred to the Committee shall be considered as undisposed of, the head of the Council shall resume the chair and proceed with the next order of business. On motion duly passed during any subsequent regular meeting of Council, any by-law or other item of business left undecided by a motion to rise without reporting may be again considered in the Committee of the Whole.

29.4 *Chair Votes*

The Chair of the Committee of the Whole may vote on any question. In the event of an equality of votes the question being voted upon shall be deemed to have been decided in the negative.

29.5 *Debate from Chair*

The Chair of the Committee of the Whole may state relevant facts as well as their position on any matter and debate the question before the Committee without leaving the Chair.

29.6 *Report of Committee of the Whole*

The proceedings and findings of the Committee of the Whole may be reported by the Chair to Council as soon as the Committee rises and shall be received forthwith. A motion for the concurrence of Council in the report of the Committee or a motion adopting the report of the Committee and dealing with the subject matter thereof shall be in order.

## **COMMITTEES**

### **30. Rules Applying to all Committees**

30.1 *Definition*

Committees of Council include:

- a) Advisory and other committees or boards whose members are appointed by Council for an ongoing purpose;
- b) Special committees appointed by Council or the head of Council at any time as is deemed necessary for the consideration of special matters.

Task forces composed of a majority of staff members are not intended to be subject to the provisions of this by-law.

30.2 *Mayor Ex Officio*

The head of Council is an ex officio member of every committee but the head of Council shall not be counted in the formation of a quorum.

30.3 *Quorum (Boards and Committees)*

A committee shall not consider any business if a quorum is not present. A quorum for a board or committee is a majority of the members.

#### 30.4 *Notice*

Not less than 24 hours notice of a meeting shall be given to the members of any committee and wherever possible an Agenda shall be provided to the members in advance of the meeting.

#### 30.5 *Secretary*

A secretary shall be appointed for each committee who shall:

- a) Keep the minutes of the meetings of the committee;
- b) Give notice of meetings;
- c) Post a copy of all minutes to the municipal website;
- d) Perform such other clerical functions as may be required.

#### 30.6 *Application of Legislation*

Boards and committees of Council are subject to the provisions of this by-law, the *Municipal Act, 2001*, and the *Municipal Conflict of Interest Act*.

#### 30.7 *Absence of Board or Committee Members*

Where a member of a board or committee of Council is absent from meetings for three successive months without being authorized to do so by a resolution of the board or committee, the board or committee may request that Council declare the seat vacant.

#### 30.8 *Refusal to Call Meetings, etc.*

- a) Should the Chair of any committee neglect or refuse to call meetings of a committee at such times or with such frequency as the proper dispatch of the committee's business requires; or do the business of the committee without the knowledge or consent of its members, or contrary to their wishes or sanction, the committee may report such neglect, refusal or action to Council, which may remove such Chair from office and appoint another member of the committee in their place.
- b) Should any member of a committee refuse or neglect to attend the regular or special meetings thereof, the Chair may report such neglect or refusal to Council, which may remove such member from the committee and appoint another member in their place.

#### 30.9 *Chair Votes*

The Chair of a committee may vote on any question before the committee and in the event of an equality of votes the question being voted on shall be deemed to have been defeated.

#### 30.10 *Committee Appointments*

Appointments to boards and committees having the same term as the term of Council shall expire at the end of the term of Council or until such time as successors are appointed.

Council will meet in open session, either at a regular meeting or special meeting called for that purpose to make appointments to boards and committees.

Appointments are not limited to eligible electors only, except where provided otherwise by statute.

No citizen shall be appointed to more than five boards or committees.

No City employee shall be appointed as a voting member of any board or committee of Council (excluding task forces).

*Nominating Task Force*

A Nominating Task Force, consisting of three members of Council and six members of City staff shall consider all citizen applications with reference to particular skills required by various boards and committees. The Nominating Task Force shall provide a slate of recommended citizen applicants to Council for its consideration.

When considering citizen appointments to a particular board or committee, members of Council shall consider the recommended slate of applicants recommended by the Nominating Task Force. Council shall nominate members of Council for consideration of appointments requiring a member of Council.

*Where Number of Applicants Exceeds Positions*

Where the number of applicants exceeds the number of positions available, the following procedure shall be followed, for as many voting rounds as necessary:

- a) Each member may cast a vote for each position available;
- b) Applicants receiving a majority vote of members present shall be recommended for appointment;
- c) Applicants receiving no votes shall be excluded from further consideration;
- d) In addition to those applicants receiving no votes, applicants receiving the least amount of votes shall be excluded from further consideration, unless this would result in insufficient applicants to fill the positions available;
- e) If two or more applicants are tied with the least number of votes and their exclusion would result in insufficient applicants to fill the positions available:
  - i. Council shall decide by majority vote which of the tied applicants shall remain eligible for further consideration; however
  - ii. If the vote still results in too few applicants to fill the remaining position(s), then the City Clerk shall choose the person(s) to remain eligible by lot;
- f) If it becomes apparent by reason of an equality of votes that no applicant can achieve sufficient votes to be appointed, then the City Clerk shall make the selection by lot.

*Method – Simultaneous Recorded Vote*

- g) Each member present, unless otherwise prohibited by statute or this by-law, shall (on a sheet of paper provided by the City Clerk) simultaneously indicate the names of the applicant they are voting for and sign the same. In an electronic meeting the sheets shall be displayed on the members' screens simultaneously;
- h) The City Clerk shall:
  - i. announce the name and vote of each member and the vote result; and



- ii. record the result, including how each member voted.

#### 30.11 *Police Record Checks*

Members of boards and committees of Council that have direct contact with vulnerable individuals or handle cash may be required to provide a clear police record check.

### **31. Special Committees**

#### 31.1 *Appointment*

Special committees of Council may be appointed by the Council or head of Council at any time as is deemed necessary for the consideration of special matters.

#### 31.2 *Jurisdiction*

A resolution establishing a special committee shall set forth the terms of reference of the committee and such other provisions as the Council shall deem proper.

#### 31.3 *Chair*

Unless specified in the resolution establishing a special committee, the special committee members shall select the committee Chair at the initial meeting of the committee.

#### 31.4 *Membership*

Where the resolution establishing a special committee does not appoint members thereto the head of Council shall appoint them.

#### 31.5 *Meetings*

Special committees shall meet at such time and place as the Chair or committee shall determine. No special committee shall meet while the Council is in session.

#### 31.6 *Report in Writing*

Each special committee shall diligently pursue its duties and shall report to the Council on matters and questions referred to it. A final or interim report of a special committee must be made in writing and be signed by the Chair.

#### 31.7 *Confined to Matters Referred*

Special committees may consider and report on such matters only as have been referred to them by the Council or the head of Council.

#### 31.8 *Refusal to Give Due Attention*

Should any special committee neglect or refuse to give due attention to any matter before it the Council may by resolution discharge such committee and appoint another in its place.

#### 31.9 *Dissolution*

When a special committee has completed its work and made its report it dissolves automatically.

#### 31.10 *Attendance by Members of Council*

Members of the Council may attend the meetings of special committees, but shall not be allowed to vote; nor shall they be allowed to take part in any discussion or debate except by the permission of the majority of the members of the committee.

### **GENERAL PROVISIONS**

## **32. General**

### **32.1 *Standing Rules Suspended***

Any standing rule, order of Council, or provision of this by-law may be suspended by resolution of Council provided that two-thirds of the members of the Council present vote in favour thereof.

### **32.2 *Rules of Parliament***

All proceedings of the Council or Committees not specifically provided for herein shall be dealt with in accordance with James Lochrie's *Meeting Procedures: Parliamentary Law and Rules of Order for the 21<sup>st</sup> Century* and in such cases the decision of the head of Council or Chair as the case may be shall be final and accepted without debate or appeal.

### **32.3 *Addresses of Members of Council***

Notices of meetings, Agendas and other information shall be sent to the member's City email address and any such notice, Agenda or other information is duly sent or given if sent to that email address.

### **32.4 *Execution of Documents***

Whenever, to give effect to any motion or by-law of the Corporation or to perform any of the statutory duties of the Corporation, the execution of any document is required, the head of Council and the City Clerk are hereby authorized for and in the name of the Corporation to execute and to affix the seal of the Corporation to such documents.

### **32.5 *Electronic Devices***

Each member shall place any electronic device on an inaudible setting during any open or closed session.

### **32.6 *Attendance in Council Chamber***

No person except members of Council and appointed officials of the City shall be permitted to come within or behind the horseshoe during a meeting of Council without the permission of the head of Council, or, if an objection is raised by any member of Council to such permission being granted, then by a majority of Council.

### **32.7 *Anonymous Communications***

Anonymous communications will not be circulated to members of Council or retained as an official record.

### **32.8 *Administrative Corrections***

The City Clerk has the authority to make administrative corrections to official records of Council.

### **32.9 *Severability***

Each and every provision of this by-law is deemed severable and if a court or tribunal of competent jurisdiction declares any portion of this by-law to be illegal, invalid or unenforceable, that portion of this by-law shall be severed and shall be inoperative from the balance of the by-law. The remainder of this by-law shall remain operative and continue to operate in full force and effect.

### **32.10 *Repeal***

By-laws 2013-100, 2014-18, 2015-86, 2016-213, 2018-212, 2019-192, 2020-54, 2020-76, 2020-144, 2021-67 and 2022-100 are hereby repealed.

32.11 *Effect*

This by-law comes into force on the day of its final passing.

PASSED in open Council this 19<sup>th</sup> day of June, 2023

---

Mayor Matthew Shoemaker

---

City Clerk Rachel Tyczinski

\\citydata\LegalDept\Legal\Staff\COUNCIL\BY-LAWS\2023\2023-100 Council Procedure.docx

# THE CORPORATION OF THE CITY OF SAULT STE. MARIE

## BY-LAW 2023-101

**DELEGATION TO THE CHIEF ADMINISTRATIVE OFFICER (“CAO”); DEPUTY CAO OF COMMUNITY DEVELOPMENT AND ENTERPRISE SERVICES AND DIRECTOR OF TOURISM AND COMMUNITY DEVELOPMENT**: A by-law to approve the standard form Tourism Development Fund (“TDF”) Agreement and delegate to the Chief Administrative Officer (“CAO”) signing authority to execute same on behalf of the City when the monetary amount to be contributed by the City is \$30,000 or greater and up to the CAO’s approval limit of \$125,000.00; and further delegate to the Chief Administrative Officer of Community Development and Enterprise Services signing authority to execute same on behalf of the City when the monetary amount to be contributed by the City is up to \$30,000; and further delegate to the Director of Tourism and Community Development signing authority to execute same on behalf of the City when the monetary amount is up to \$10,000; all of which delegated authority shall be effective after the applicable TDF Agreement has been reviewed and approved by the Legal Department.

**WHEREAS** Section 23.1(1) of the Municipal Act, 2001, S.O. 2001, c. 25, as amended, allows for City Council to delegate Council's powers under the Municipal Act, 2001 to officers and employees of the City;

**NOW THEREFORE THE COUNCIL** of The Corporation of the City of Sault Ste. Marie, pursuant to section 23.1(1) of the *Municipal Act, 2001*, S.O. 2001, c. 25 as amended, **ENACTS** as follows:

1. **FORM OF TOURISM DEVELOPMENT FUND AGREEMENT**

The Corporation of the City of Sault Ste. Marie does hereby authorize and approve the standard form TDF Agreement as set out in Schedule “A” hereto.

2. **EXECUTION OF DOCUMENT AND POWERS DELEGATED**

- (i) The Council hereby delegates to the Chief Administrative Officer, Deputy CAO of Community Development and Enterprise Services and Director of Tourism and Community Development, signing authority to execute the TDF Agreement substantially in the form of Schedule “A” on behalf of The Corporation of the City of Sault Ste. Marie.
- (ii) The Chief Administrative Office, Deputy CAO of Community Development and Enterprise Services and Director of Tourism and Community Development is further authorized to make minor variations from this standard form TDF Agreement to suit the particular needs of the user and circumstances regarding the amendment required.

3. **SCHEDULE “A”**

Schedule “A” forms part of this By-law.

4. **EFFECTIVE DATE**

This by-law takes effect on the day of its final passing, and will cover any agreements from June 19, 2023 onward.

**PASSED** in open Council this 19<sup>th</sup> day of June, 2023.

---

**MAYOR – MATTHEW SHOEMAKER**

---

**CITY CLERK – RACHEL TYCZINSKI**

**Schedule "A"**

**THE CORPORATION OF THE CITY OF SAULT STE. MARIE**

**GRANT AGREEMENT**

**THE AGREEMENT** is effective as of the **INSERT DATE**

**BETWEEN:**

**THE CORPORATION OF THE CITY OF SAULT STE. MARIE**

(hereinafter referred to as the "City")

-and-

**INSERT NAME**

(hereinafter referred to as the "Recipient")

**WHEREAS**

The City wishes to provide a grant to the Recipient approved by City Council through the Tourism Development Fund to assist with supporting tourism related initiatives.

**NOW THEREFORE** the parties hereto agree as follows:

**1. TERM**

The Agreement will commence on the Effective Date and will expire on **INSERT DATE** (the "Term") unless terminated by the City pursuant to the terms contained herein.

**2. USE OF FUNDS**

The Recipient acknowledges and agrees to the following:

- i. To use the Funds solely for the activities and/or service costs for **INSERT EVENT NAME AND EVENT DATE**
  - **INSERT and LIST ELIGIBLE EXPENSE LINES (FOR EXAMPLE MARKETING) IF APPLICABLE**
- ii. That the Funds shall not be used to cover any expense that has or will be funded or reimbursed by a third party, ministry, agency, or other organization.

**3. FUNDS PROVIDED**

The City shall:

- i. Provide the Recipient with **INSERT FUNDING AMOUNT** (the "Funds") for the purpose as stated above;

- ii. Provide the Funds by depositing same into an account designated by the Recipient provided that the account:
  - a) Resides at a Canadian financial institution; and
  - b) Is in the name of the Recipient organization.

The Recipient shall, upon expiry of the Agreement, forthwith return to the City any remaining Funds in its possession using a method of payment that is agreeable to the City.

### **3.1 Repayment of Overpayment**

If at any time the City provides Funds to the Recipient in an amount in excess to that which the Recipient is entitled to under the Agreement, the City may demand that the Recipient repay an amount equal to the excess Funds to the City, wherein the Recipient shall forthwith comply.

## **4. ACCOUNTING RECORDS**

The Recipient shall maintain accounting records that document the receipt of the City Funds and all expenditures related to same "accounting records". The Recipient shall keep those accounting records for at least seven (7) years after the expiration of the Term. The City retains the right to review or audit those accounting records at any time and the Recipient shall provide full access to any and all such records as requested by the City.

## **5. REPORTS**

The Recipient shall:

- i. Submit to the City all receipt documents and proof of payment for the grant monies;
- ii. Ensure that all Reports are signed on behalf of the Recipient by an authorized signing officer; and
- iii. Upon the request of City Council, present to City Council in the last quarter of calendar year on a date specified by the City a summary of the Recipient's financial state, including but not limited to a summary of its funding, revenue and expenses, and a summary of the impact that the City funding has had, if any, on fulfilling the mandate of the organization.

## **6. TERMINATION**

The City may, at its sole discretion, cancel this Agreement on sixty (60) days' written notice to the Recipient. In the event of such early termination of this Agreement, the Recipient acknowledges that same shall result in the immediate stoppage of any future payment of Funds from the City up to the date of termination, provided however, that in the event that the City elected to terminate the Agreement as a result of a default of the terms and conditions of the Agreement, the sole determination of which shall be made by the City in its sole discretion, the remedies, terms and amounts set out in Section 7 herein shall apply.

## **7. DEFAULT**

The Recipient agrees that any default to the terms and conditions contained herein by the Recipient shall result in the immediate stoppage of payments from the City and immediate termination of the Agreement. The Recipient further agrees that a default arising from any use of Funds that is contrary to the terms of this Agreement as determined by the City may also result in the repayment of Funds to the City in an amount proportionate to the Funds that were improperly used in a method of payment specified by the City.

## **8. LAWS**

This Agreement shall be governed by and construed in accordance with the laws of the Province of Ontario and the laws of Canada in force in the Province of Ontario.

## **9. WAIVER**

No waiver by any party hereto of any breach by any other party of any of its covenants, agreements or obligations contained in this Agreement shall be or be deemed to be a waiver of any subsequent breach thereof or the breach of any other covenants, agreements or obligations, nor shall any forbearance by any party hereto to seek a remedy for any breach by any other party be a waiver by the party so forbearing of its rights and remedies with respect to such breach or any subsequent breach.

## **10. LEASE**

There are no covenants, representations, warranties, agreements or other conditions expressed or implied, collateral or otherwise, forming part of or in any way affecting or relating to this Lease, save as expressly set out or incorporated by reference herein. This Lease constitutes the entire agreement duly executed by the parties, and no amendment, variation or change to this Lease shall be binding unless the same shall be in writing and signed by the parties.

## **11. COUNTERPARTS**

This Agreement may be executed in several counterparts, each of which when so executed shall be deemed to be an original and such counterparts together shall constitute one and the same instrument and shall be effective as of the formal date hereof.

## **12. SIGNATURES**

The parties hereto agree that the signatures and/or initials on this Agreement or its acceptance, rejection or modification can be transmitted by FAX or similar electronic transmission and that communication by such means will be legal and binding on all parties as if this document was executed and delivered in the original.



**13. NOTICE**

Any notice pursuant to any of the provisions of this Agreement shall be given in writing addressed:

***In the case of notice to the City:***

Travis Anderson  
Director Tourism & Community Development  
Community Development & Enterprise Services  
The Corporation of the City of Sault Ste. Marie  
99 Foster Drive  
Sault Ste. Marie, ON P6A 5X6

***In the case of notice to the Recipient:***

**INSERT CONTACT NAME AND CONTACT INFORMATION**

**IN WITNESS WHEREOF** the parties hereto have executed this Agreement the day, month and year first above written.

**THE CORPORATION OF THE CITY OF SAULT STE. MARIE**

\_\_\_\_\_

NAME:  
TITLE

**RECIPIENT NAME**

\_\_\_\_\_

NAME  
*I have the authority to bind the organization.)*

**THE CORPORATION OF THE CITY OF SAULT STE. MARIE**

**BY-LAW 2023-102**

**ENGINEERING:** A by-law to authorize the execution of the Contract between the City and Pioneer Construction Inc. for Carmen's Way resurfacing (Contract 2023-8E).

**THE COUNCIL** of The Corporation of the City of Sault Ste. Marie, pursuant to section 9 of the *Municipal Act, 2001*, S.O. 2001, c. 25, **ENACTS** as follows:

1. **EXECUTION OF DOCUMENT**

The Mayor and City Clerk are hereby authorized for and in the name of the Corporation to execute and affix the seal of the Corporation to the Contract dated June 19, 2023 between the City and Pioneer Construction Inc., a copy of which is attached as Schedule "A" hereto. This Contract is for Carmen's Way resurfacing (Contract 2023-8E).

2. **SCHEDULE "A"**

Schedule "A" forms part of this by-law.

3. **EFFECTIVE DATE**

This by-law takes effect on the day of its final passing.

**PASSED** in open Council this 19<sup>th</sup> day of June, 2023.

---

**MAYOR – MATTHEW SHOEMAKER**

---

**CITY CLERK – RACHEL TYCZINSKI**

da \LEGAL\STAFF\COUNCIL\BY-LAWS\2023\2023-102 - CONTRACT 2023-8E CARMEN'S WAY RESURFACING.DOCX

Schedule "A"

**THE CORPORATION OF THE CITY OF SAULT STE. MARIE  
CARMEN'S WAY RESURFACING  
Contract No 2023-8E**

**FORM OF AGREEMENT**

This Agreement, made (in triplicate) this June day of 19 in the year 2023, by and between Pioneer Construction Inc., hereinafter called the "**Contractor**",

AND

The Corporation of the City of Sault Ste. Marie, hereinafter called the "**Owner**".

WITNESSETH: That the Contractor and the Owner undertake and agree as follows:

1. The Contractor will provide all the materials and all of the works shown and described in the Contract Documents entitled:

**CARMEN'S WAY RESURFACING  
Contract No 2023-8E**

which have been signed in triplicate by both parties and which were prepared by City of Sault Ste. Marie, acting as Contract Administrator, and herein entitled, "The Contract Administrator".

2. The Contractor will do and fulfill everything indicated by the Agreement (being this form of agreement), Addenda (if any), the Special Provisions, Contract Drawings, the Standard Specifications, Standard Drawings, Tender, Supplemental General Conditions, OPSS.MUNI 100 (November 2019 version or newest), and working drawings.

3. The Contractor will complete all the work under the supervision and direction and to the entire satisfaction of the Contract Administrator within the period of time specified.

4. The Owner shall pay to the Contractor the contract price as set forth in the Form of Tender in accordance with the provisions set forth in the General Conditions, Supplemental General Conditions, and the Special Provisions. The quantities contained in the Form of Tender are approximate only and the final payment shall be made for the actual quantities that are incorporated in or made necessary by the work covered by the contract.

5. The Owner shall pay the Contractor for work that is ordered in writing by the Contract Administrator and that cannot be classified as coming under any of the contract units and for which no unit price, lump sum, or other basis can be agreed upon, on a time and material basis as set out in the General Conditions.

6. The Contractor, both during and after the term of this Agreement, shall at all times, and at its own cost, expense and risk, defend, indemnify and hold harmless the Owner and, its elected officials, officers, employees, volunteers, agents, the Contract Administrator, all respective heirs and executors, successors and assigns, from all loss, damages, costs,

charges and expenses of every nature and kind whatsoever which may be made or brought against them, their officers, employees and agents, by reason or in consequence of the execution and performance or maintenance of the work by the Contractor, its employees, agents or officers.

7. Prior to the commencement of any work, the Contractor shall sign and deliver to the Public Utilities Commission of the City of Sault Ste. Marie, PUC Distribution Inc. and PUC Services Inc., the PUC Indemnity attached as Schedule "A" which forms part of this Agreement wherein.

8. All communications in writing between the Owner, the Contractor and the Contract Administrator shall be deemed to have been received by the Addressee if delivered to the individual, a member of the firm or an officer of the Owner for whom they are intended, or if sent by post or by telegram addressed as follows:

**Owner:** The Corporation of the City of Sault Ste. Marie  
99 Foster Drive  
Sault Ste. Marie, Ontario  
P6A 5X6

**The Contractor:** Pioneer Construction Inc.  
845 Old Goulais Bay Road,  
Sault Ste. Marie, ON P6A 0B5

**The Contract Administrator:** The Corporation of the City of Sault Ste. Marie  
Civic Centre  
99 Foster Drive  
Sault Ste. Marie, Ontario P6A 5X6

**IN WITNESS WHEREOF** the parties hereto have executed this Agreement by the day and year first above written.

Signed, Sealed and Delivered in the presence of

**THE CORPORATION OF THE CITY OF SAULT STE. MARIE**

\_\_\_\_\_  
MAYOR –MATTHEW SHOEMAKER

\_\_\_\_\_  
MUNICIPAL CLERK –RACHEL TYCZINSKI

**THE CONTRACTOR (COMPANY NAME)**

\_\_\_\_\_  
SIGNATURE

NAME: \_\_\_\_\_

I have authority to bind the corporation

THE CORPORATION OF THE CITY OF SAULT STE.MARIE

**BY-LAW 2023-104**

**OFFICIAL PLAN AMENDMENT:** A by-law to adopt Amendment No. 247 to the Official Plan for the City of Sault Ste. Marie (Cara Community Corporation-Geoff Meakin-352/360 Northern Ave East and 31 Old Garden River Road).

**THE COUNCIL** of The Corporation of the City of Sault Ste. Marie, pursuant to section 17 of the *Planning Act*, R.S.O. 1990, c. P.13 and amendments thereto, **ENACTS** as follows:

1. The Council hereby adopts Amendment No. 247 to the Official Plan for the Sault Ste. Marie planning area in the form attached hereto.
2. Subject to any referrals under the Planning Act, this by-law shall come into force on the date of its final passing.

PASSED in open Council this 19<sup>th</sup> day of June, 2023.

---

**MAYOR - MATTHEW SHOEMAKER**

---

**CITY CLERK – RACHEL TYCZINSKI**

lv \\citydata\LegalDept\Legal\Staff\LEGAL\ZONING\2023\Northern Avenue, 360\By-law 2023-104 OP.docx

**AMENDMENT NO. 247  
TO THE  
SAULT STE. MARIE OFFICIAL PLAN**

**PURPOSE**

This Amendment is an amendment to the Text of the Official Plan as it relates to the Housing and Commercial Policies, and to the Land Use Map (Schedule C).

**LOCATION**

PT SEC 32 TARENTORUS; PT LT 18 RCP H732 TARENTOROUS PTS 2, 3, 4, 6 & 7, 1R-13874; S/T T232886; SAULT STE. MARIE; PT SEC 32 TARENTOUS; PT LT 18 RCP H732 TARENTOROUS PT 1, 1R-13874; S/T T342880; SAULT STE. MARIE, having Civic Number 352/360 Northern Avenue and 31 Old Garden River Road, located at the northeast corner of the Northern Avenue East and Great Northern Rd.

**BASIS**

The Text Amendments are necessary in view of an application to permit:

- a. New commercial development up 750m<sup>2</sup> on residential lands
- b. Permit major office space outside of the Downtown Area

Council now considers it desirable to amend the Official Plan.

**DETAILS OF THE ACTUAL AMENDMENT & POLICIES RELATED THERETO**

The Official Plan for the City of Sault Ste. Marie is hereby amended by adding the following paragraph to the Special Exceptions Section:

162. Notwithstanding Residential Policy R.7 and Commercial Policy C.4 of the Official Plan, the property described PT SEC 32 TARENTORUS; PT LT 18 RCP H732 TARENTOROUS PTS 2, 3, 4, 6 & 7, 1R-13874; S/T T232886; SAULT STE. MARIE; PT SEC 32 TARENTOUS; PT LT 18 RCP H732 TARENTOROUS PT 1, 1R-13874; S/T T342880; SAULT STE. MARIE, having Civic Number 352/360 Northern Avenue and 31 Old Garden River Road, located at the northeast corner of the Northern Avenue East and Great Northern Rd., may allow commercial including major office space upon the subject area development up to 750m<sup>2</sup> and be located outside the Downtown Area.

**INTERPRETATION**

The provisions of the Official Plan as amended from time to time will be applied to this Amendment.

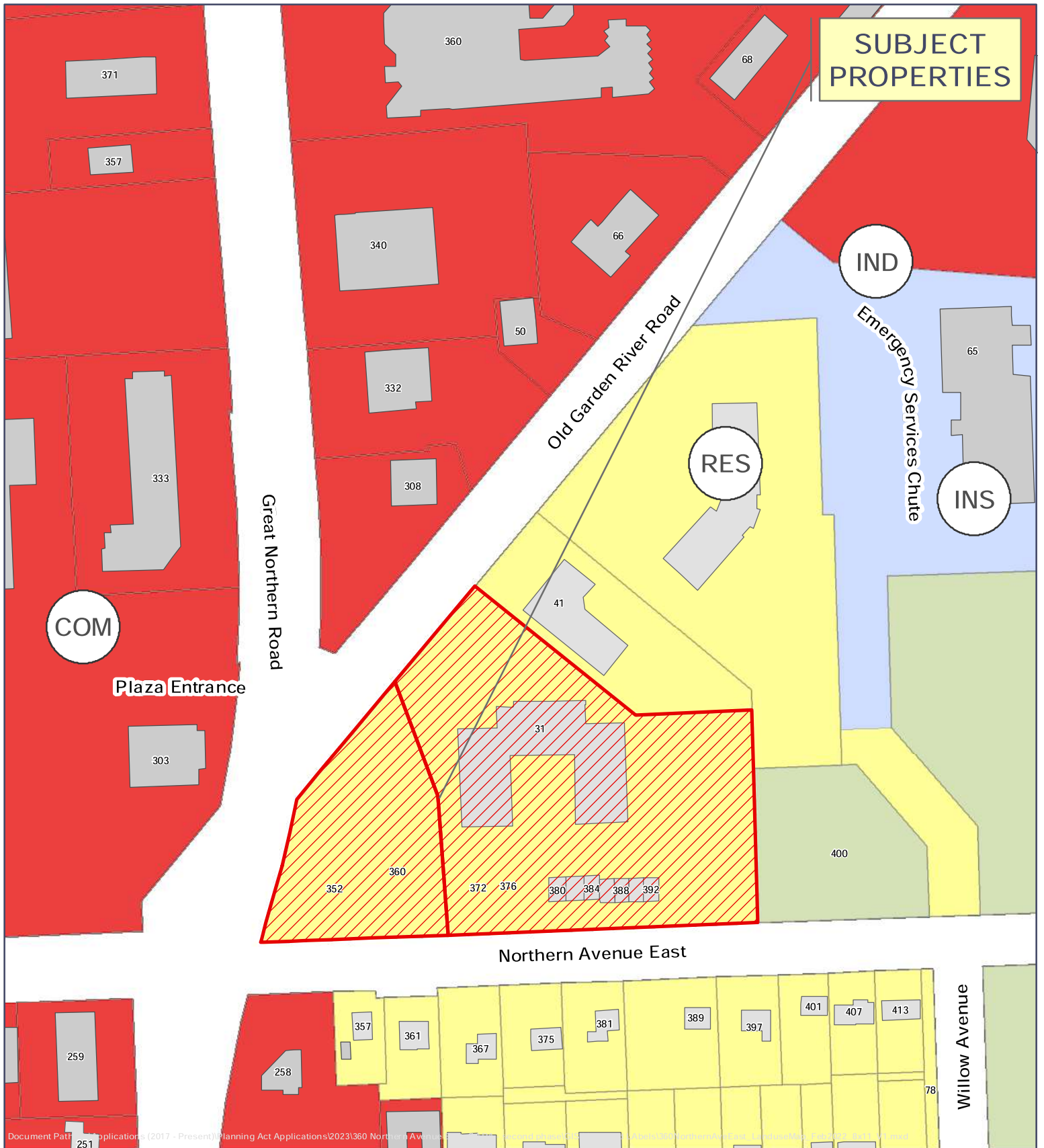

**SUBJECT PROPERTIES**

IND

RES

INS

COM

Plaza Entrance

Emergency Services Chute

Great Northern Road

Old Garden River Road

Northern Avenue East

Willow Avenue

Document Path: Applications (2017 - Present)\Planning Act Applications\2023\360 Northern Avenue East - 31 Old Garden River Road - 352/360 Northern Avenue East - 31 Old Garden River Road

**Application Map Series**  
 Subject Property  Official Plan Land Use  
 Existing Zoning  Aerial Image  
 Official Plan Amendment

**Property Information**  
 Civic Address: 352/360 Northern Avenue East,  
 31 Old Garden River Road  
 Roll No.: 030081001000000, 030081002000000  
 Map No.: 71/1-76  
 Application No.:  
 Date Created: May 15, 2023

**Legend**

- Subject Properties:  
352/360 Northern Avenue East,  
31 Old Garden River Road
- Residential
- Commercial
- Institutional
- Parks Recreation
- Industrial
- Rural Area
- Airports
- Parcel Fabric

**SAULT STE. MARIE**  
 Planning and Enterprise Services  
 Community Development and Enterprise Services Department  
 99 Foster Drive, Sault Ste Marie, ON P6A 5X6  
 saultstemarie.ca | 705-759-5368 | planning@cityssm.on.ca  
*This map is for general reference only*  
 Orthophoto: None  
 Projection Details:  
 NAD 1983 UTM Zone 16N  
 GCS North American 1983

0 10 20 40 Meters  
 1:2,000

**THE CORPORATION OF THE CITY OF SAULT STE. MARIE**

**BY-LAW NO. 2023-105**

**ZONING:** A by-law to amend Sault Ste. Marie Zoning By-laws 2005-150 and 2005-151 concerning lands located at 352/360 Northern Ave East and 31 Old Garden River Road (Cara Community Corporation-Geoff Meakin).

**THE COUNCIL** of The Corporation of the City of Sault Ste. Marie, pursuant to section 34 of the *Planning Act*, R.S.O. 1990, c. P.13 and amendments thereto, **ENACTS** as follows:

1. **352/360 NORTHERN AVENUE EAST AND 31 OLD GARDEN RIVER ROAD; LOCATED ON THE NORTHEAST CORNER OF NORTHERN AVENUE EAST AND GREAT NORTHERN ROAD; CHANGE FROM R5.S-405 TO R5.S WITH A NEW “SPECIAL EXCEPTION”**

The zone designation on the lands described in Section 2 of this by-law, which lands are shown on Map 71/1-76 of Schedule “A” to By-law 2005-150, is changed from R5.S-405 (High Density Residential) zone with Special Exception 405 to R5.S (High Density Residential) zone with a new “Special Exception”.

2. **BY-LAW 2005-151 AMENDED**

Section 2 of By-law 2005-151 is amended by adding the following subsection 2(405) and heading as follows:

**“2(405) 352/360 Northern Avenue East and 31 Old Garden River Road**

Despite the provisions of By-law 2005-150, the zone designation on the lands located on the northeast corner of Northern Avenue East and Great Northern Road and having civic no. 352/360 Northern Avenue East and 31 Old Garden River Road and outlined and marked “Subject Property” on the map attached as Schedule 405 hereto is changed from R5.S-405 (High Density Residential) zone with Special Exception 405 to R5.S (High Density Residential) zone with a new “Special Exception”, to permit, in addition to those uses permitted in an R5 zone up to 750m<sup>2</sup> of commercial space, subject to the following provisions:

- a) Permitted commercial uses include office uses, food services, personal services, retail trade, amusement and fitness facilities,



arts culture and heritage uses, bingo halls, accessory uses and similar. The foregoing uses are subject to the same regulations as the proposed apartment building;

- b) Reduce the required east interior side yard setback to from 13.5m to 0m to accommodate an enclosed corridor between the proposed building and the existing building on the abutting property;
- c) Reduce the combined number of required parking spaces from 185 to 101 spaces for the proposed 108-unit apartment building, the existing 4-unit multiple attached dwellings, the place of worship, and the commercial use of the property;
- d) Provide a minimum of nine barrier-free parking spaces;
- e) Reduce the west exterior side yard setback from 13.5m to 4m;
- f) Permit parking within the required front (south) and exterior (west) side yards;
- g) Waive the need to provide a dedicated loading space as required by Section 6 of the Zoning By-Law; and
- h) Reduce the required landscaped open space from 33% to 29%.”

3. **SCHEDULE “A”**

Schedule “A” hereto forms a part of this by-law.

4. **CERTIFICATE OF CONFORMITY**

It is hereby certified that this by-law is in conformity with the Official Plan for the City of Sault Ste. Marie authorized and in force on the day of the passing of this by-law as amended by Official Plan Amendment No. 247.

PASSED in Open Council this 19<sup>th</sup> day of June, 2023.

---

**MAYOR – MATTHEW SHOEMAKER**

---

**CITY CLERK – RACHEL TYCZINSKI**

SCHEDULE "A" TO BY-LAW 2023-105 AND  
SCHEDULE 405 TO BY-LAW 2005-151

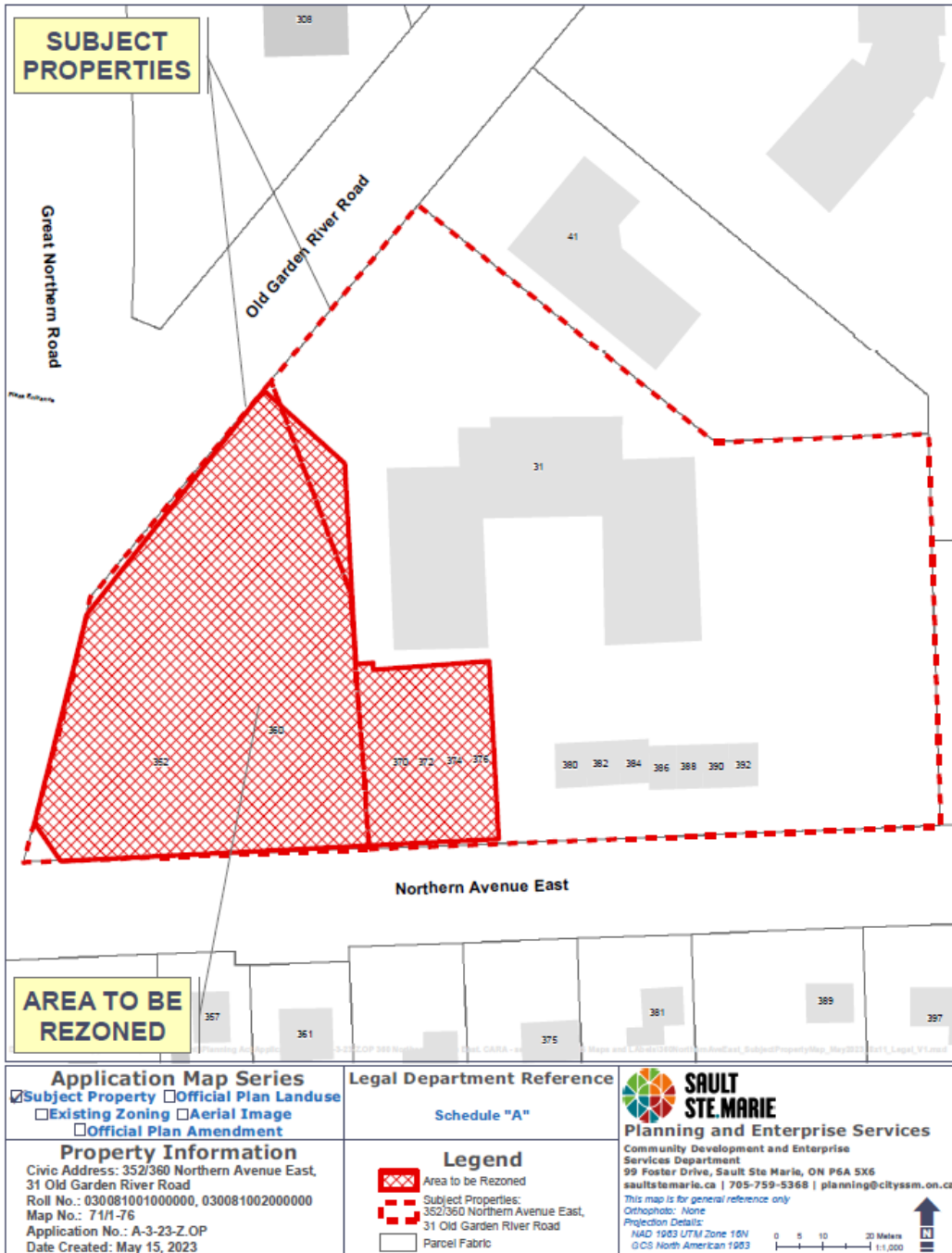

<p><b>Application Map Series</b></p> <p><input checked="" type="checkbox"/> Subject Property <input type="checkbox"/> Official Plan Landuse</p> <p><input type="checkbox"/> Existing Zoning <input type="checkbox"/> Aerial Image</p> <p><input type="checkbox"/> Official Plan Amendment</p>	<p><b>Legal Department Reference</b></p> <p>Schedule "A"</p>	<p><b>SAULT STE. MARIE</b></p> <p><b>Planning and Enterprise Services</b></p> <p>Community Development and Enterprise Services Department 99 Foster Drive, Sault Ste Marie, ON P6A 5X6 saultstemarie.ca   705-759-5368   planning@cityssm.on.ca</p> <p><i>This map is for general reference only</i></p> <p>Orthophoto: None Projection Details: NAD 1983 UTM Zone 18N GCS North American 1983</p> <p>0 5 10 20 Miles 0 1 2 3 Kilometers</p>
<p><b>Property Information</b></p> <p>Civic Address: 352/360 Northern Avenue East, 31 Old Garden River Road</p> <p>Roll No.: 030081001000000, 030081002000000</p> <p>Map No.: 71/H-76</p> <p>Application No.: A-3-23-Z-OP</p> <p>Date Created: May 15, 2023</p>	<p><b>Legend</b></p> <p> Area to be Rezoned</p> <p> Subject Properties: 352/360 Northern Avenue East, 31 Old Garden River Road</p> <p> Parcel Fabric</p>	

**THE CORPORATION OF THE CITY OF SAULT STE. MARIE**

**BY-LAW 2023-106**

**AGREEMENT**: A by-law to authorize the execution of the Agreement between the City and Sault Ste. Marie 49 (SSM) Field Regiment RCA Historical Society for funding for the Sault Ste. Marie Museum Capital Window Renovation Project.

**THE COUNCIL** of The Corporation of the City of Sault Ste. Marie, pursuant to section 9 of the *Municipal Act, 2001*, S.O. 2001, c. 25, **ENACTS** as follows:

1. **EXECUTION OF DOCUMENT**

The Mayor and City Clerk are hereby authorized for and in the name of the Corporation to execute and affix the seal of the Corporation to the Agreement dated June 19, 2023 between the City and Sault Ste. Marie 49 (SSM) Field Regiment RCA Historical Society. This Agreement is for funding for the Sault Ste. Marie Museum Capital Window Renovation Project.

2. **SCHEDULE "A"**

Schedule "A" forms part of this by-law.

3. **EFFECTIVE DATE**

This by-law takes effect on the day of its final passing.

**PASSED** in open Council this 19<sup>th</sup> day of June, 2023.

---

**MAYOR – MATTHEW SHOEMAKER**

---

**CITY CLERK – RACHEL TYCZINSKI**

## Schedule "A"

### AGREEMENT

This Agreement is made effective the 19<sup>th</sup> day of June, 2023.

#### **BETWEEN:**

**THE CORPORATION OF THE CITY OF SAULT STE. MARIE**

(herein referred to as the "City")

– and –

**SAULT STE. MARIE AND 49 (SSM) FIELD REGIMENT RCA HISTORICAL SOCIETY**

(herein referred to as the "Sault Ste. Marie Museum")

**WHEREAS** the City is the registered owner of the property municipally known as 690 Queen Street East (the "Premises");

**AND WHEREAS** the Sault Ste. Marie Museum operates a Museum from the Premises;

**AND WHEREAS** the Sault Ste. Marie Museum made an Application to the Canada Cultural Spaces Fund for funding for the Sault Ste. Marie Museum Capital Window Renovation project (the "Project") and was successful in securing a grant in the total amount of Ninety-Six Thousand, Four Hundred, Sixty-One (\$96,461.00) Dollars as set in a Grant Agreement between His Majesty The King in Right of Canada and the Sault Ste. Marie Museum, a copy of which is appended as Schedule "A" to this Agreement (the "Grant Agreement");

**AND WHEREAS** Section 13 of the Grant Agreement requires the Sault Ste. Marie Museum to negotiate all contracts related to the Project and further, Section 19 of the Grant Agreement provides that the Sault Ste. Marie Museum shall not assign this Agreement or any part thereof or any payments to be made thereunder without the written permission of the Minister;

**AND WHEREAS** the Sault Ste. Marie Museum acknowledges that it has requested the City to undertake and oversee the procurement, administration and expenses for the Project ("Project Work") and thereafter invoice Sault Ste. Marie Museum for all such costs related to the Project (collectively, the "Project Costs"), and further represents and warrants that it has secured confirmation from the Department of Canadian Heritage – Government of Canada (the "Minister") that it will accept the Project Work and the Project Costs as "Eligible Expenses" under the Grant Agreement and is content to have the City undertake the matters as set out herein for the Project, and on that basis, the City is agreeable to proceed with same;

**AND WHEREAS** the Sault Ste. Marie Museum undertakes to submit to the Minister the Project Work and Project Costs incurred by the City for reimbursement as "Eligible Expenses" immediately upon the City submitting same to the Sault Ste. Marie Museum and further undertakes to forthwith forward to the City any such reimbursement received under the Grant Agreement;

**AND WHEREAS** the parties hereto acknowledge that in addition, the City shall contribute the sum of Two Hundred and Eight Thousand, Five Hundred and Forty-Two (\$208,542.40) and Forty Cents to the Museum Capital Projects for the Windows;

**NOW THEREFORE** in consideration of the sum of One (\$1.00 CDN) Dollar, the receipt of which is hereby acknowledged by the City and the mutual covenants, agreements and promises hereinafter set forth, the parties for themselves and their respective permitted assigns do hereby covenant and agree with one another as follows:

**PROJECT COSTS AND PROJECT WORK**

1. The Sault Ste. Marie Museum represents and warrants that:
  - (a) it has reviewed the criteria for the Canada Cultural Spaces Fund Grant and confirms that the Project Costs and the Project Work to be incurred by the City to undertake and oversee the procurement, administration and expenses for the Project are “Eligible Expenses” under the Canada Cultural Spaces Fund Grant;
  - (b) it has requested the City to undertake and complete Project Work and Project Costs on its behalf; and
  - (c) it has provided the Minister with notice that it has requested the City to undertake the Project Work and Project Costs on its behalf and submit invoices for such costs to the Sault Ste. Marie Museum, which in turn the Sault Ste. Marie Museum will submit as Eligible Expenses pursuant to the Grant Agreement and the Minister has confirmed same is acceptable to the Minister.
2. Given the representations and warranties as set out in Section 1 herein, the City shall complete and oversee the procurement, administration and expenses for the Project and thereafter forthwith invoice Sault Ste. Marie Museum for all costs related to the Project, being the Project Work and Project Costs as defined herein.
3. The Sault Ste. Marie Museum undertakes to immediately process any invoices received by the City for the Project Work and Project Costs and submit same to the Minister as required under the Grant Agreement.
4. The Sault Ste. Marie Museum undertakes to immediately forward to the City any reimbursement the Sault Ste. Marie Museum received pursuant to the Grant Agreement.
5. The Sault Ste. Marie Museum shall be responsible for any taxes that may be assessed from this Agreement and the Grant Agreement. The City shall have no responsibility for such taxes.
6. The Sault Ste. Marie Museum shall have sole and ultimate responsibility for all matters as set out in the Grant Agreement and shall comply with all matters as set out therein.
7. The Sault Ste. Marie Museum shall provide the City with any documentation of any nature and kind that is required by the City as it relates to the Canada Cultural Spaces Fund Grant and the Grant Agreement.
8. In no event shall the City be required to reimburse the Sault Ste. Marie Museum or any other third party, for any monies the City has received from the Sault Ste. Marie Museum pursuant to the Canada Cultural Spaces Fund Grant.

9. The Sault Ste. Marie Museum shall fully indemnify and save harmless the City for any costs, expenses, penalties, assessments or requests for reimbursement that the Minister and/or related entity may make to the City as it relates to the Canada Cultural Spaces Fund Grant, the Grant Agreement, any monies received by the Sault Ste. Marie Museum, any requests for reimbursement, requests that may arise from any future audit, any breach of the Grant Agreement and any other matters related directly or indirectly to the Grant Agreement and the Canada Cultural Spaces Fund, the intent being that the City should be at no risk or expense, and the Sault Ste. Marie Museum shall bear responsibility for any issues that may arise regarding the Grant Agreement and matters set out herein.
10. In addition to the matters set out above, the parties hereto acknowledge and agree that the City shall contribute the sum of Two Hundred and Eight Thousand, Five Hundred and Forty-Two (\$208,542.40) and Forty Cents to the Museum Capital Projects for the Windows.
- TERM**
11. The Term of the Agreement shall be for a period of one (1) year commencing June 19, 2023 and ending on June 18, 2024. The City and the Sault Ste. Marie Museum shall complete all matters as required herein by the end of the Term.
12. The indemnities as set out in this Agreement shall survive the Term and termination of this Agreement.
13. The Sault Ste. Marie Museum shall be responsible to ensure that the "Activity Date" as set out in the Grant Agreement is amended and extended to cover the period of time reflected to complete the Project Work and Project Costs as per the City's procurement process, specifically to the end of December 31, 2023. The Sault Ste. Marie Museum shall immediately provide the City with written confirmation that the Activity Date as set out in the Grant Agreement has been extended as set out herein prior to the Project Work and Project Costs being commenced by the City.

**MISCELLANEOUS**

14. The Sault Ste. Marie Museum shall pay to the City all damages, costs and expenses (including, without limitation, all legal fees on a full indemnity basis) incurred by the City in enforcing the terms of this Agreement.
15. Any notice required or permitted to be given by one party to the other pursuant to the terms of this Lease may be given by email to:

To the City at:  
 Manager of Recreation & Culture  
 99 Foster Drive, Sault Ste. Marie, ON  
[v.mcleod@cityvssm.on.ca](mailto:v.mcleod@cityvssm.on.ca)

To the Sault Ste. Marie Museum at:  
 Executive Director and Chief Curator  
[william@saultmuseum.ca](mailto:william@saultmuseum.ca)

Such notice will be effective on the date the email is sent.



**THE CORPORATION OF THE CITY OF SAULT STE. MARIE**

**BY-LAW 2023-107**

**APPOINTMENTS:** A by-law to appoint Inspectors under the *Building Code Act, 1992* and Municipal Law Enforcement Officers under the *Police Services Act*.

**THE COUNCIL** of the Corporation of the City of Sault Ste. Marie pursuant to the *Building Code Act, 1992* and of the *Police Services Act, R.S.O. 1990*, **ENACTS** as follows:

1. **SCHEDULE “A” TO BY-LAW 2012-168 AMENDED**

Schedule “A” to By-law 2012-168 is hereby repealed and replaced with Schedule “A” attached to this by-law.

2. **SCHEDULE “A”**

Schedule “A” hereto forms part of this by-law.

2. **EFFECTIVE DATE**

This by-law takes effect on the day of its final passing.

**PASSED** in open Council this 19<sup>th</sup> day of June, 2023.

---

**MAYOR – MATTHEW SHOEMAKER**

---

**CITY CLERK – RACHEL TYCZINSKI**



**Building Inspector's for the  
City of Sault Ste. Marie**

**Part 3 - Building Inspectors**

Frank Bentrovato

Frank Bumbaco

Kevin Lavergne

**Part 9 - Building Inspectors**

Alex Roussell

Glen Irwin

Toni-Marie Streicher

# THE CORPORATION OF THE CITY OF SAULT STE. MARIE

## BY-LAW 2023-108

**PROPERTY STANDARDS**: A by-law to amend By-law 2012-9 (the Property Standards By-law for The Corporation of the City of Sault Ste. Marie).

**THE COUNCIL** of The Corporation of the City of Sault Ste. Marie pursuant to section 15.1 (3) of the *Building Code Act*, 1992, S.O. 1992, c.23, and amendments thereto, ENACTS as follows:

### 1. **BY-LAW 2012-9 AMENDED**

- a) Delete the fees listed under Schedule “A” of by-law 2012-9.
- b) Delete the word “Chapters” in Paragraph 2.02 Yards 2) c.
- c) Delete and replace all reference to the word “Chapter” and replace with the word “by-law”, except where “Chapter” is used in Appeal to Property Standards Committee paragraph which states “Ontario Building Code Act, S.O. 1992, Chapter 23, Section 15.3(1)”.
- d) Delete and replace all reference to the title “Chief Official” and replace with the title “Chief Building Official”.
- e) Subsection 1.01 (7), 1.01 (24) and subsection 1.01 (25) of By-law 2012-9 are hereby deleted and replaced with the following:
  - 7) “Chief Building Official” means the Chief Building Official appointed under Section 3 of the *Building Code Act*, 1992, c. 23 and shall include the Property Standards Officer, and their designate.
  - 24) “Officer” shall include the Chief Building Official, a Property Standards Officer or Property Standards Inspector, a Building Inspector, or a Municipal Law Enforcement Officer, as appointed;
  - 25) “owner” shall include:
    - (a) the registered owner of the land on which the building is situated;
    - (b) the owner of a building;
    - (c) the person managing or receiving the rent of the land or the building, or who would receive the rent if the land and building were let, whether on the person’s own account or as agent or trustee or receiver of any other person;

- (d) a vendor of the building under an agreement for sale who has paid any municipal taxes thereon after the effective date of the agreement;
- (e) the person for the time being receiving installments of the purchase price if the building were sold under an agreement for sale;
- (f) a lessee or occupant of the property who, under the terms of a lease, is required to repair and maintain the building;
- (g) an owner as defined by the *Condominium Act* 1998, S.O. 1998, c. 19, as amended and any successor legislation; and,
- (h) any person having care and control of the land or building.

f) Part 7 and Part 8 of By-law 2012-9 are hereby deleted and replaced with the following:

**PART 7**  
**Vacant – Demolished – Damaged Buildings**

7.1 Definition applicable to Part 7 of this by-law:

- 1. “vacant building” shall have the same meaning as the City’s Vacant Building By-law, as amended, and in the case of a building damaged by fire or other, be deemed vacant from the incident date wherein the property was no longer habitable.
- 2. “Vacant land” means any property within the City of Sault Ste Marie without any dwelling or accessory building whatsoever.

7.2 BUILDING DAMAGED BY FIRE OR OTHER:

- 1. Where a vacant building or building is damaged by fire, an explosion, or any other means and is boarded or required to be boarded, the owner shall:
  - (a) use boarding materials with at least 12.7 mm (0.5 inch) weatherproof sheet plywood securely fastened to the building and painted a color compatible with the surrounding walls;
  - (b) boarding materials shall be installed to exclude rain and wind from entering the building and to secure the building from unauthorized entry, and shall be installed within the reveal of the opening frame or cladding, where feasible; and
  - (c) damaged or partially burned material shall be removed from the premises, except that such material may be temporarily stored within the barricaded damaged building or structure, provided that such storage does not exceed ninety (90) days from the date of the incident.

2. Fire damaged buildings, or portions thereof, shall be repaired to their original condition or shall be demolished accordingly within 90 days from the date of the incident.

3. Where any building is vacant or is damaged by accident, storm, neglect or otherwise, and in the opinion of an officer or the chief building official or an inspector appointed under the *Building Code Act*, 1992 it is not feasible to repair the building to the standards prescribed by this By-law without first demolishing the building or a portion of it, the owner shall demolish the building or portion of it that it is not feasible to repair within one year of it becoming so.

### 7.3 DEMOLISH BUILDING:

1. Where a building, accessory building, fence or other structure is demolished and removed of all containments, the property shall be cleared of all rubbish, waste, refuse, masonry, lumber, wood, and other materials and left in a graded, and leveled condition. If directed by any officer to do so, four (4) inches of top soil and grass seed shall be added to the officer's satisfaction.

2. Where a building, accessory building, fence or other structure is being demolished, every precaution shall be taken to protect the adjoining property and members of the public. The precautions to be taken include the erection of fences, barricades, covered walkways for pedestrians and any other means of protection necessary for the protection of the adjoining property and members of the public.

3. All demolitions shall adhere to any applicable legislation.

### 7.4 COST RECOVERY

1. Where the City does or causes work to be done on a vacant building or a building damaged by fire, an explosion, or any other means to comply with Part 7 of this By-law, with or without notice, such work shall be done at the expense of the owner and shall be collected by the City in the same manner as property taxes.

### 7.5 FEES

1. Where a vacant building is not in compliance with this By-law and requires an Officer to inspect the property to enforce compliance, an

'inspection fee" shall be determined by the Officer after every inspection in accordance with Schedule "E" and the City of Sault Ste. Marie User Fee By-law and submitted to the owner.

2. Every owner shall pay the fees determined in subsection 7.7 (1) of this by-law, which become due and payable upon an Officer submitting a written request to an owner of the inspection amount per the City of Sault Ste. Marie User Fee By-law. If not paid forthwith, the City may add the cost to the tax roll.

## **PART 8 ADMINISTRATION AND ENFORCEMENT**

### **8.0 ENFORCEMENT**

1. This By-law shall be administered and enforced by an Officer who is hereby authorized to enforce the provisions of this By-law.
2. No person shall obstruct or hinder, or attempt to obstruct or hinder, an Officer, in the exercise of a power or the performance of a duty under this By-law.
3. No person shall refuse to produce any documents or things required by an Officer under this By-law, and every person shall assist any entry, inspection, examination, or inquiry by an Officer.
4. No person shall knowingly furnish false information to the City or an Officer with respect to this By-law.

### **8.1 OFFICERS RIGHT OF ACCESS**

1. An Officer may enter upon and within, and inspect any land, property, building or structure at any time to determine if any section of this by-law is complied with, or to determine if any direction, notice or order issued pursuant to this By-law or the *Municipal Act*, 2001 as amended or any court has been complied with, or to perform any remedial work authorized by this By-law.
2. Notwithstanding subsection 8.1 (1), the Officer shall not enter or remain in any room or place actually used as a dwelling unless the provisions of Section 437 of the *Municipal Act*, 2001, as amended are complied with.
3. The Officer shall have inspection powers described in Section 436 of the *Municipal Act*, 2001, as amended.

## 8.2 ORDERS - NOTICE - NON-COMPLIANCE

1. Where an owner is in contravention of any provision of this By-law, an Officer, in addition to any other actions or orders under the Building Code Act, 1992, as amended, may send an informal notice, in the form of a letter or email, to the owner, describing the contravention.
2. Any notice or direction given under this By-law shall be deemed good and sufficient service if:
  - (a) personally delivered to the person to whom it is directed,
  - (b) provided by a previously established electronic means of communication
  - (c) mailed by ordinary or registered mail, and delivery to the mailing address of the owner of the property, according to the last revised Assessment Roll of the property which does not comply with this By-law, or
  - (d) by being posted on the subject property.
3. Where any person fails to comply with an order issued pursuant to section 15.2 of the Building Code, the municipality may cause the required work to be done at the cost of the person. The cost of such work may be recovered by action or by adding the costs to the tax roll of the subject property and collecting them in the same manner as property taxes.

## 8.3 PENALTY

1. Any person or owner who contravenes this By-law is guilty of an offence and is liable upon conviction to a penalty recoverable under the *Provincial Offences Act*, R.S.O. 1990, c. P.33, as amended.
2. A director or officer of a corporation who knowingly concurs in the contravention of this By-law by the corporation is guilty of an offence and is liable upon conviction to a penalty recoverable under the *Provincial Offences Act*, R.S.O. 1990, c. P.33, as amended.
3. A person who is convicted of a continuing offence under this By-law is liable to a fine of not more than \$5,000 for each day or part of a day that the offence continues.
4. An owner who fails to comply with an order that is final and binding under this By-law is guilty of an offence under Section 36(1) of the *Building Code Act*, S.O. 1992, c.23, and is liable to a penalty or penalties as set out in Section 36 of that Act, as amended.

#### 8.4 COLLECTION OF UNPAID FINES

1. Where a fine is in default, the City may proceed with civil enforcement against the person upon whom the fine has been imposed, pursuant to the Provincial Offences Act, R.S.O. 1990, c.P.3.
2. The City may make a request to the Treasurer of the City to add any part of a fine that is in default to the tax roll for any property in the local municipality for which all of the owners are responsible for paying the fine, and collect it in the same manner as municipal taxes.

#### 8.5 CONTINUATION, REPETITION PROHIBITED BY ORDER

1. The Court in which the conviction has been entered and any court of competent jurisdiction thereafter may make an order prohibiting the continuation or repetition of the offence by the person convicted, and such order shall be in addition to any other penalty imposed on the person convicted.

### **PART 9 GENERAL PROVISIONS**

9.1 Application - This Bylaw shall apply to all property within the limits of the municipality.

9.2 Measurements - The imperial measurements contained in this Bylaw are given for reference only.

9.3 Conflicting legislation - Where a provision of this by-law conflicts with the provisions of another by-law, Act Regulation in force within the municipality, the provision, which establishes the higher standards to protect the health, safety and welfare of the occupants and the general public, shall prevail.

9.4 Legislation - Nothing in this bylaw shall be deemed to grant relief from the requirements of the *Building Code Act*, 1992, the *Building Code*, the *Fire Protection and Prevention Act*, 1997, or the *Fire Code*. Nor shall this by-law be viewed as limiting the Officer's election to proceed under any of the said legislation wherein they have reasonable grounds that a violation exists.

9.5 Severability - It is hereby declared that each and every of the foregoing provisions of this by-law is severable and that, if any provisions of this by-law should, for any reason, be declared invalid by any Court, it is the intention and desire of this Council that each and every of the then remaining provisions hereof shall remain in full force and effect.

**9.6 Validity** - If any provision or article of this Bylaw is for any reason found to be invalid by a court of competent jurisdiction, the provision or article found to be invalid shall be severed from the Chapter and the remaining provisions or article shall remain in effect until repealed.

2. **REPEAL BY-LAW 2021-128**

By-law 2021-128 is hereby repealed.

3. **EFFECTIVE DATE**

This by-law takes effect on the day of its final passing.

PASSED in open Council this 19<sup>th</sup> day of June, 2023.

---

**MAYOR – MATTHEW SHOEMAKER**

---

**CITY CLERK – RACHEL TYCZINSKI**



## THE CORPORATION OF THE CITY OF SAULT STE. MARIE

### BY-LAW 2023-109

**YARD MAINTENANCE**: A by-law to amend By-law 2012-10 (the Yard Maintenance By-law for The Corporation of the City of Sault Ste. Marie).

**THE COUNCIL** of the Corporation of the City of Sault Ste. Marie, pursuant to the provisions of section 10 of the *Municipal Act, 2001*, S.O., 2001 c.25 and amendments thereto, **ENACTS** as follows:

#### 1. **BY-LAW 2012-10 AMENDED**

- a) The below shall be added to By-law 2012-10 directly above the paragraph starting with "THE COUNCIL":

**"WHEREAS** the *Municipal Act, 2001*, S.O. 2001, c. 25, as amended, s. 8, provides that the powers of a municipality shall be interpreted broadly so as to confer broad authority on the municipality to enable the municipality to govern its affairs as it considers appropriate and to enhance the municipality's ability to respond to municipal issues;

**AND WHEREAS** the *Municipal Act, 2001*, S.O. 2001, c. 25, as amended, s. 9, provides that a municipality has the capacity, rights, powers, and privileges of a natural person for the purpose of exercising its authority;

**AND WHEREAS** the *Municipal Act, 2001*, S.O. 2001, c. 25, as amended, s. 128, provides that a local municipality may prohibit and regulate with respect to public nuisances, including matters that, in the opinion of Council, are or could become or cause public nuisances;

**AND WHEREAS** offences and penalty provisions for contraventions are as set out in section 425, 429 and 431 of the *Municipal Act, 2001*, S.O. 2001, c. 25, as amended;

**AND WHEREAS** the *Municipal Act, 2001*, S.O. 2001, c. 25, as amended, s. 445, provides that if a local municipality is satisfied that a contravention of a by-law has occurred, the municipality may make an order requiring the person who contravened the by-law or who caused or permitted the contravention or the owner or occupier of the land on which the contravention occurred to do work to correct the contravention; and

**AND WHEREAS** Municipal Council of The Corporation of the City of Sault Ste. Marie is deems yard maintenance regulations necessary to prevent nuisances and the accumulation of waste, debris, and refuse."

b) By adding subsection “4 b):

The owner or occupant shall adhere to the above written notice of breach of this by-law by the Chief Building Official within the time prescribed in the order.”

**2. EFFECTIVE DATE**

This by-law takes effect on the day of its final passing.

PASSED in open Council this 19<sup>th</sup> day of June, 2023.

---

**MAYOR – MATTHEW SHOEMAKER**

---

**CITY CLERK – RACHEL TYCZINSKI**

\\citydata\LegalDept\Legal\Staff\COUNCIL\BY-LAWS\2023\2023-109 Yard Maintenance.docx

## THE CORPORATION OF THE CITY OF SAULT STE. MARIE

### BY-LAW 2023-110

**VACANT BUILDING**: A by-law to enact the Vacant Building By-law for The Corporation of the City of Sault Ste. Marie.

**WHEREAS** section 15.1 of the *Building Code Act, 1992*, S.O. 1992, c. 23 provides that the council of a municipality may pass a by-law with respect to prescribing standards for the maintenance and occupancy of property, and requiring property that does not conform with the standards to be repaired and maintained to conform with the standards or the site to be cleared of all buildings, structures, debris or refuse and left in graded and levelled condition;

**AND WHEREAS** section 15.4 of the *Building Code Act, 1992* provides authority for a municipality to cause repairs or demolition of a property where an order of a property standards officer made under section 15.2(2) of the Act is not complied with and the order has been deemed confirmed or has been confirmed or modified by a property standards committee or judge of the Superior Court of Justice, and further provides that the municipality shall have a lien on the land for the amount of the repair or demolition, which shall have priority lien status under the *Municipal Act, 2001*;

**AND WHEREAS** section 15.9(4) of the *Building Code Act, 1992* provides authority for a building inspector who finds that a building is unsafe to order remedial work to render the building safe;

**AND WHEREAS** section 15.9(6) of the *Building Code Act, 1992* provides that where an order of a building inspector under s. 15.9(4) of that Act is not complied with within the time specified in the order, the Chief Building Official may cause the building to be renovated, repaired or demolished to remove the unsafe condition or take such other action as the Chief Building Official considers necessary for the protection of the public; and section 15.9(10) provides that in such a case the municipality shall have a lien on the land for the amount spent on the renovation, repair, demolition, or other action taken, and that the amount shall have priority lien status under the *Municipal Act, 2001*;

**AND WHEREAS** section 15.10 of the *Building Code Act, 1992* provides that, where a building inspector is satisfied that a building poses an immediate danger to the health or safety of any person, the Chief Building Official may make an order containing particulars of the dangerous conditions and requiring remedial repairs or other work to be carried out immediately to terminate the danger; and further that the costs of the work done by the municipality, in an amount determined by a judge of the Superior Court of Justice to be recoverable, shall be a lien on the land and shall have priority lien status as described in section 1 of the *Municipal Act, 2001*;

**AND WHEREAS** sections 8, 9, and 10 of the *Municipal Act, 2001*, S.O. 2001, c. 25 provide municipalities with broad powers, including the ability to pass by-laws that the

municipality considers necessary or desirable for the public and, in particular, paragraphs 5, 6, 8 and 10 of subsection 10(2) of that Act authorize municipalities to pass by-laws respecting the economic, social and environmental well-being of the municipality; the health, safety and well-being of persons; the protection of persons and properties; and structures;

**AND WHEREAS** the *Municipal Act, 2001*, S.O. 2001, c. 25, as amended, s. 128, provides that a local municipality may prohibit and regulate with respect to public nuisances, including matters that, in the opinion of Council, are or could become or cause public nuisances;

**AND WHEREAS** section 391(1) of the *Municipal Act, 2001* provides that a municipality may impose fees or charges on persons (a) for services and activities provided or done by or on behalf of it, and (b) for costs payable by it for services or activities provided or done by or on behalf of any other municipality or any local board;

**AND WHEREAS** section 444 of the *Municipal Act, 2001* provides authority, if a municipality is satisfied that a contravention of a by-law passed under that Act has occurred, for the municipality to make an order requiring the person who contravened the by-law or who caused or permitted the contravention, or the owner or occupier of the land on which the contravention occurred to discontinue the contravening activity;

**AND WHEREAS** section 446 of the *Municipal Act, 2001* provides that where a municipality has the authority by any Act or by-law to direct or require a person to do a matter or thing, the municipality may also provide that, in default of it being done by the person directed or required to do so, the matter or thing shall be done at the person's expense and the municipality may recover the costs of doing the matter or thing from the person directed or required to do it, by action or by adding the costs to the tax roll and collecting them in the same manner as taxes;

**AND WHEREAS** offence and penalty provisions for contraventions are as set out in section 36 of the *Building Code Act, 1992* and sections 425, 429 and 431 of the *Municipal Act, 2001*;

**AND WHEREAS** this By-law is one of several City by-laws that ensure buildings and properties are maintained to minimum standards including the Property Standards By-law and the Yards Maintenance By-law;

**AND WHEREAS** it is the opinion of the Council of The Corporation of the City of Sault Ste Marie that vacant buildings that are not secured against unauthorized entry constitute public nuisances by attracting vandals and creating fire and safety hazards, and it is the desire of the Council of The Corporation of the City of Sault Ste. Marie to regulate vacant buildings;

**THE COUNCIL** of The Corporation of the City of Sault Ste. Marie pursuant to section 15.1 (3) of the *Building Code Act, 1992*, S.O. 1992, c.23, and amendments thereto, in addition

to sections 8, 9, 10, 128, and 446 of the *Municipal Act*, 2001, S.O. 2001, c. 25, as amended, ENACTS as follows:

## **Part 1 – Interpretation and Application**

### **1.1 Short Title**

1.1.1 This By-law may be referred to as “The Vacant Buildings By-law”.

### **1.2 Application – All Buildings**

1.2.1 This By-law shall apply to all buildings in the City.

### **1.3 Reference Aids**

1.3.1 The headings and subheadings used in this By-law are inserted for convenience of reference only and do not form part of the By-law and shall not affect in any way the meaning or interpretation of the provisions of this By-law.

### **1.4 Severability**

1.4.1 If any provision or part of a provision of this By-law is declared by a court of competent jurisdiction to be illegal or inoperative in whole or in part, or inoperative in particular circumstances, such provision or part of the provision shall be deemed to be severable, and the balance of the By-law, or its application in other circumstances, shall not be affected and shall continue to be in full force and effect.

### **1.5 Compliance with Legislation**

1.5.1 Nothing in this By-law relieves any person from complying with any provision of any federal or provincial legislation, or any other by-law of the City of Sault Ste. Marie and, without limiting the generality of the foregoing, this includes the *Building Code Act, 1992*, the *Fire Protection and Prevention Act, 1997*, S.O. 1997, c. 4; and the *Municipal Act, 2001*.

### **1.6 Conflict**

1.6.1 If a provision of this By-law is in conflict with a provision of any applicable act, regulation or other by-law, the provision that establishes the higher or more restrictive standard shall apply.

### **1.7 Delegation**

1.7.1 The administration of this By-law is hereby delegated to the Chief Building Official or their designate.

## 1.8 Definitions

1.8.1 The following definitions shall apply in this By-law. In addition, the definitions in the *Building Code Act, 1992*, S.O. 1992, c. 23, as amended and the Building Code shall apply with respect to matters pertaining to buildings unless otherwise defined in this By-law.

**“Building Code Act, 1992”** means the *Building Code Act, 1992*, S.O. 1992, c. 23, as amended, and any successor legislation.

**“Building Code”** means O. Reg.332/12 made under the *Building Code Act, 1992*, and any successor regulation.

**“Building Division”** means the Building Department of the City of Sault Ste. Marie.

**“Chief Building Official”** means the Chief Building Official for the City of Sault Ste. Marie, as appointed by Council under section 3 of the *Building Code Act, 1992*, or their designate.

**“City”** means The Corporation of the City of Sault Ste. Marie or the area within the geographical limits of the City of Sault Ste. Marie, as the context requires.

**“Council”** means the Council for The Corporation of the City of Sault Ste. Marie.

**“Demolish”** means to tear down and remove from the subject land building(s) and/or structure(s), and ‘demolition’ has a corresponding meaning.

**“Graffiti”** means one or more letters, symbols or marks, howsoever made, that disfigure or deface a property or object, but does not include a sign pursuant to the City’s sign bylaws or a mural which has been authorized by the City.

**“Officer”** means a Property Standards Officer appointed by the City to administer and enforce this By-law and the City’s Property Standards By-law or, where specified, the Chief Building Official or a Building Inspector appointed by Council pursuant to s. 3(2) of the *Building Code Act, 1992*.

**“Owner”** means:

- a) the registered owner of the land on which a building is situated;
- b) the owner of a building;
- c) the person managing or receiving the rent of land or a building, or who would receive the rent if the land and building were let, whether on the person’s own account or as agent or trustee or receiver of any other person;
- d) a vendor of a building under an agreement for sale who has paid any municipal taxes thereon after the effective date of the agreement;

- e) the person for the time being receiving installments of the purchase price if a building were sold under an agreement for sale;
- f) a lessee or occupant of a property who, under the terms of a lease, is required to repair and maintain the building; and
- g) an owner as defined by the *Condominium Act 1998*, S.O. 1998, c. 19, as amended and any successor legislation.

**“Property”** means the land on which a building is situated and includes the building.

**“Property Standards Committee”** means a committee established by Council pursuant to s. 15.6 of the *Building Code Act, 1992* and the City’s Property Standards By-Law.

**“Register”** means to comply with the requirements of this By-law concerning registration of vacant buildings.

**“Secure”** means to maintain a building in a condition that reasonably prevents access to the interior of the building, or to the exterior of the building, if deemed unsafe by an Officer, and may include locking, infilling, sealing, or boarding of doors, windows, or other openings in a wall or roof of a building, or the installation of security measures or warning signage, and may also include demolition.

**“Undesirable Material”** includes:

- a) rubbish, garbage, brush, waste, litter and debris;
- b) injurious insects, termites, rodents, vermin and other pests;
- c) growth of grass or weeds in excess of 8 inches;
- d) ground cover, hedges, and bushes which overhang the sidewalk, impede pedestrian or vehicular traffic or cause a site obstruction;
- e) dead, decayed or damaged trees or other natural growth and the branches and limbs thereof which create an unsafe condition;
- f) wrecked, dismantled, inoperative, discarded, unused, or unlicensed vehicles or trailers, except in an establishment licensed or authorized to conduct or operate a wrecking business;
- g) stagnant water which provides a breeding place for mosquitos or other health hazards;
- h) machinery or parts thereof, or other objects or parts thereof, or accumulation of material that creates an adverse condition;
- i) dilapidated or collapsed structures or erections;
- j) furniture used for exterior use that becomes dilapidated;
- k) furniture designed for indoor use; and
- l) animal or human excrement.

**“User Fees By-law”** means the City’s User Fees By-law or any successor bylaw thereto.

**“Vacant building”** means a building that is not being used or occupied for a period exceeding 30 consecutive days, including days vacant prior to the passage of this By-law, but does not include:

- a) a dwelling unit occupied by the Owner on a seasonal basis but otherwise maintained throughout the year;
- b) the owner is away for an extended period of time because of health treatment;
- c) a building, except a dwelling unit, on property used as a farm; or
- d) a building that is owned by the City.

**“Vacant Building Registry”** means the City list of vacant buildings maintained by the City’s Building Division.

## **Part 2 – Vacant Buildings**

### **2.1 Owner Responsibilities – All Vacant Buildings**

2.1.1 Every owner of a vacant building shall:

- a) register the vacant building in accordance with Part 3 of this By-law;
- b) ensure that the property complies with all applicable statutes, regulations and bylaws, including, but not limited to, the *Building Code Act, 1992* and the *Fire Protection and Prevention Act, 1997*;
- c) protect the property against the risk of fire, accident or other danger;
- d) effectively prevent the entrance of any unauthorized persons, including but not limited to effectively boarding up the vacant building;
- e) use materials for boarding up the vacant building that are covered and maintained with preservative compatible with the surrounding exterior finish of the building;
- f) where openings that were previously boarded or secured, become unsecured, re-secure such openings, using materials and fasteners of greater strength, installed in such a manner to deter their destruction or removal;
- g) ensure that water, electrical and gas services are turned off with the exception of those services that are required for the security and maintenance of the property;



- h) maintain a minimum of two million dollars of general liability insurance per occurrence on the vacant building;
- i) ensure the vacant building is inspected on a regular basis by a person or company familiar and qualified with the matters pertaining to this By-law, maintain a written record of all inspections, including the date and time of the inspection, and produce the records upon the request of an Officer;
- j) if a vacant building is so designated pursuant to the *Ontario Heritage Act*, bring the inclusion or heritage designation to the Officer's attention, to ensure compliance with all other laws or By-laws respecting the property;
- k) exterior walls of a building and their components shall be free of inappropriate signs, painted slogans, graffiti and similar defacements;
- l) maintain a set of floor plans showing the current floor configuration of the vacant building; and
- m) ensure the property does not remain vacant for a period exceeding one year.

### **Part 3 – Registration of Vacant Buildings**

#### **3.1 Registration**

- 3.1.1 Every owner of a vacant building which has been vacant for at least 30 consecutive days, including days vacant prior to the passage of this By-law, shall register the building within the subsequent 30 days, in accordance with this Part.
- 3.1.2 Where there is more than one vacant building on a property, the owner shall register each vacant building individually.
- 3.1.3 Where an owner fails to register a vacant building within the time required by s. 3.1.1 of this By-law, an Officer who reasonably believes that the vacant building poses a risk to safety or is a public nuisance or could become a public nuisance may add such building to a Vacant Building Registry for information and tracking purposes.
- 3.1.4 Where an Officer has added a vacant building to the Vacant Building Registry the Officer shall provide notice to the owner that they are required to complete the registration under s. 3.1.1 and the owner shall comply. Nothing in this section

relieves from the owner's responsibility to register the vacant building under s. 3.1.1.

### **3.2 Registration – Application Requirements**

- 3.2.1 To register a vacant building, the owner shall complete and submit to the City a completed and signed application form, which form shall be developed and maintained by the City, along with a set of floor plans showing the current floor configuration of the vacant building per s. 2.1.1(l) of this By-law, a current certificate of insurance demonstrating compliance with the insurance requirements of s. 2.1.1(h) of this By-law, and the applicable fee as required by Part 5 of this By-law and the City's User Fees By-law.
- 3.2.2 Every owner shall ensure the information provided on the application form is complete and correct, and is maintained current, after registration. The owner shall immediately notify Building Division of any change in circumstances in connection with information given during registration or when there is a signed agreement for sale of the property or building.
- 3.2.3 The City will not accept an application for registration that is incomplete or is known to be incorrect or inaccurate.

### **3.3 Registration – Expires**

- 3.3.1 A registration expires:
- a) when the City is satisfied that the building is no longer vacant;
  - b) when the vacant building is sold or otherwise transferred to a new owner;
  - c) when the registration is revoked by the City for false, incomplete, or misleading information;
  - d) when the building is demolished; or
  - e) where none of the foregoing circumstances occur, on the one-year anniversary date of the date on which the registry permit was issued.

## **Part 4 – Orders Relating to Vacant Buildings**

### **4.1 Order – Unauthorized Entry**

- 4.1.1 Where an Officer finds that a vacant building is not secure from unauthorized entry, the provisions of this section shall apply.

- 4.1.2 The Officer may make an Order to discontinue the contravention pursuant to s. 444 of the *Municipal Act, 2001*, requiring the building to be secured against unauthorized entry.
- 4.1.3 An Order issued under this section shall set out reasonable particulars of the contravention adequate to identify the contravention, the location, and the date by which there must be compliance with the Order.
- 4.1.4 In addition to the requirements of s. 4.1.3, an Order issued under this section may include particulars on the acceptable method(s) of securing the vacant building by way of security measures and/or devices to the satisfaction of the City, and such measures may include boarding of windows, doors and other openings. Where, in the sole discretion of the Officer, a specific method of securing the property, such as boarding in part or in whole, is required to ensure that the vacant property remains secured against unauthorized entry, the Order shall state this requirement.
- 4.1.5 An Order to secure a vacant building against unauthorized entry may be served on the owner personally, by registered mail, or by posting the Order at the site of the vacant building.
- 4.1.6 Where the circumstances do not reasonably allow the property owner to secure the building forthwith, the owner shall ensure that the property is monitored by a responsible person at all times until the building is adequately secured and, in any event, the owner shall ensure compliance with the Order by the deadline to comply.

## **4.2 Emergency Order – Unauthorized Entry**

- 4.2.1 Where, in the opinion of an Officer, it would pose an immediate danger to the health or safety of any person to allow a vacant building to remain unsecured for even a short period of time, the Officer may issue an Order under section 15.7 of the *Building Code Act, 1992*, requiring that the building be secured immediately and, in such circumstances, the provisions of this section shall apply.
- 4.2.2 An Order issued under this section shall contain particulars of the contravention and the work required to be carried out, and the requirement to do the work immediately.
- 4.2.3 Upon making the Order, the Officer may, either before or after the Order is served, take any measures necessary to secure the building in order to terminate the danger and, for this purpose, the City may, through its employees and agents, at any time enter upon the property without a warrant.
- 4.2.4 The Order shall be served on the owner and any such other persons affected thereby as the Officer determines, and a copy shall be posted on the property,

either before the City takes measures to secure the building, or as soon as practicable after the measures have been taken.

- 4.2.5 The Officer shall ensure that all other provisions of s. 15.7 of the *Building Code Act, 1992* are complied with.

### **4.3 Order – Demolition**

- 4.3.1 An Officer may issue an Order directing the owner to demolish a vacant building in accordance with the provisions of this section.
- 4.3.2 An Officer who is a Building Inspector may issue an Order to demolish a vacant building where the vacant building is insecure from unauthorized entry to the extent that it cannot, in the opinion of the Officer, be reasonably or effectively secured by boarding or other means of repair. In such circumstances, the provisions of section 15.9 of the *Building Code Act, 1992* relating to unsafe buildings shall apply.
- 4.3.3 An Officer who is a Building Inspector may issue an Order to demolish a vacant building where the security measures of the vacant building are frequently breached, in spite of repeated attempts to re-secure as described above. In such circumstances, the provisions of section 15.9 of the *Building Code Act, 1992* relating to unsafe buildings shall apply.
- 4.3.4 An Officer may issue an Order to demolish a vacant building where the vacant building has remained on the Vacant Building Registry for a period of one year. In such circumstances, the provision of sections 15.2, 15.3 and 15.4 of the *Building Code Act, 1992* relating to property standards by-laws shall apply.
- 4.3.5 Where a vacant building has been demolished pursuant to an Order to demolish, the owner shall further ensure compliance with the City's Property Standards By-law, specifically, but not limited to a vacant yard.

### **4.4 Compliance with Order**

- 4.4.1 Every owner to whom an Order is issued under this By-law shall comply with the Order by the date indicated for compliance in the Order.

### **4.5 Remedial Measures by the City**

- 4.5.1 If an Order issued under this By-law is not complied with, the City may cause the property to be secured or demolished, or may cause the safety or security measures to be taken, as the case may be, in accordance with the following time lines:

- a) where an Order to secure a building is issued under s. 4.1 of this By-law, at any time after expiry of the deadline to comply set out in the Order;
  - b) where an Emergency Order to secure a building is issued under s. 4.2 of this By-law, at any time after the Emergency Order is issued;
  - c) where an Order to demolish an unsafe vacant building is issued by a Building Inspector under s. 4.3.2 or s. 4.3.3 of this By-law, at any time after expiry of the deadline to comply set out in the Order; and
  - d) where an Order to demolish a vacant building due to passage of time is issued under s. 4.3.4 of this By-law:
    - (i) immediately upon the Order being deemed confirmed under s. 15.3(2) of the *Building Code Act, 1992*;
    - (ii) where the Order is appealed to the Property Standards Committee and is subsequently confirmed or modified by the Committee, but is not appealed to the Superior Court of Justice, upon the expiration of both the 14-day appeal period and the deadline for compliance in the confirmed or modified Order; or
    - (iii) where the Order is further appealed to the Superior Court of Justice and is subsequently confirmed or modified by a judge of the Superior Court of Justice, upon expiration of the deadline for compliance in the confirmed or modified Order.
- 4.5.2 Save for the where the building is subject to and Emergency Order, in the case of any demolition, a report and supporting by-law confirming demolition of the vacant building will be presented to Council.
- 4.5.3 For the purpose of subsection 4.5.1 of this By-law, employees or agents of the City may enter the property at any reasonable time, without a warrant, in order to secure or demolish the property, or to take the safety or security measures required as set out in the Order.
- 4.5.4 The City or a person acting on its behalf is not liable to compensate the owner, occupant or any other person by reason of anything done by or on behalf of the City in the reasonable exercise of its powers under subsection 4.5.1 of this By-law.
- 4.5.5 Where the City takes remedial action under s. 4.5.1 of this By-law, the cost recovery provisions of this By-law shall apply.

## **Part 5 – Fees**

## **5.1 Fees**

- 5.1.1 Fees for registration of a vacant building shall be levied in accordance with the City's User Fees By-law, and the owner of the building shall be responsible for payment of any registration fees arising under this By-law, as set out in the City's User Fees By-law, as amended, whether the building was registered by the owner or by an Officer pursuant to s. 3.1.3 of this By-law.
- 5.1.2 Every owner shall pay the fees imposed pursuant to the City's User Fees By-law which become due and payable upon written notification by an Officer, or upon issuance of an invoice by the City.
- 5.1.3 Where an owner is in default of payment of fees for more than 30 calendar days after due, the City may add the cost to the tax roll of the subject property and collect the amount in the same manner as property taxes.

## **Part 6 – Cost Recovery**

### **6.1 Work done by City – Owner's Expense**

- 6.1.1 Where the City does work or causes work to be done on a vacant building or a building damaged by fire to comply with this By-law, such work shall be done at the expense of the owner.
- 6.1.2 If the City undertakes the work to correct the contraventions, the owner will be charged 100% of the cost of any third party invoices plus any costs as defined in the City's User-Fee By-law.
- 6.1.3 The City shall have a lien on the land for the amount spent on the securing or demolition or other work done under the provisions of this By-law in accordance with the following:
  - a) where the remedial work is done pursuant to s. 4.5.1(a) of this By-law (in relation to an Order to secure a building under s. 4.1, the City shall have a lien on the land in the amount of the costs, including interest in the amount of 15%, upon the registration of a notice of lien in the proper land registry office;
  - b) where the remedial work is done pursuant to s. 4.5.1(b) of this By-law (in relation to an Emergency Order to secure a building under s. 4.2, the City shall have a lien on the land in the amount of the costs, as determined by a judge of the Superior Court of Justice under s. 15.7(8)(b) of the *Building Code Act, 1992* and the amount shall have priority lien status as described in s. 1 of the *Municipal Act, 2001*;

c) where the remedial work is done pursuant to s. 4.5.1(c) of this By-law (in relation to an Order to demolish an unsafe building under s. 4.3.2 or s. 4.3.3, the City shall have a lien on the land in the amount of the costs, and the amount shall have priority lien status as described in s. 1 of the *Municipal Act, 2001*; and

d) where the remedial work is done pursuant to s. 4.5.1(d) of this By-law (in relation to an Order to demolish due to passage of time under s. 4.3.4), the City shall have a lien on the land in the amount of the costs and the amount shall have priority lien status as described in s. 1 of the *Municipal Act, 2001*.

## **6.2 Non-payment by Owner – Collected as Property Tax**

6.2.1 If the owner fails to pay the cost of work completed under this By-law within 30 days of the work being completed, the amount shall be added to the tax roll of the subject property and collected in the same manner as municipal taxes.

## **Part 7 – Inspection and Enforcement**

### **7.1 Authority to Enforce**

- 7.1.1 The provisions of this By-law relating to public nuisance may be enforced by a Property Standards Officer.
- 7.1.2 The provisions of the By-law relating to unsafe buildings may be enforced by the Chief Building Official or a Building Inspector.

### **7.2 Inspection – at Any Reasonable Time**

- 7.2.1 Every Officer may enter upon any property at any reasonable time without a warrant for the purpose of inspecting the property to determine compliance with the provisions of this By-law or an Order made pursuant to this By-law.
- 7.2.2 In addition to the provisions of s. 7.2.1, an Officer who is the Chief Building Official or a Building Inspector may enter upon any land and into buildings at any reasonable time without a warrant for the purpose of inspecting the building or site to determine compliance with the provisions of this By-Law relating to unsafe buildings, and the provisions of the *Building Code Act, 1992* and the Building Code.

### **7.3 Obstruction**

- 7.3.1 No person shall hinder or obstruct, or attempt to hinder or obstruct, an Officer in the lawful exercise of a power or the performance of a duty under this By-law.

7.3.2 Any person who is alleged to have contravened any provision of this By-law shall identify himself or herself to the Officer upon request. Any failure to do so shall be deemed to be an obstruction or hindrance to the Officer in the execution the Officer's duties.

#### **7.4 Offence and Penalty**

7.4.1 Any person who fails to comply with any provision of this By-Law is guilty of an offence.

7.4.2 Any person who fails to comply with an Order issued under this By-Law is guilty of an offence.

7.4.3 A person who is convicted of an offence under this By-law is liable to a fine of not more than \$25,000 for a first offence and to a fine of not more than \$50,000 for a subsequent offence.

7.4.4 Notwithstanding subsection 7.4.3, if a corporation is convicted of an offence under this By-law, the maximum penalty that may be imposed upon the corporation is \$50,000 for a first offence and \$100,000 for a subsequent offence.

7.4.5 If a provision of this By-law is contravened and a conviction is entered, in addition to any other remedy and to any penalty imposed by this By-Law, the court in which the conviction is entered, and any court of competent jurisdiction thereafter, may make an order prohibiting the continuation or repetition of the offence by the person convicted.

### **Part 8 – Coming Into Force**

#### **8.1 Coming Into Force**

8.1.1 This By-law shall come into force and effect upon passing.

8.1.2 Subsection 2.1.1 a) and Part 3 of this By-law shall not come into force and effect on January 1, 2024.



**EFFECTIVE DATE**

This by-law takes effect on the day of its final passing.

PASSED in open Council this 19<sup>th</sup> day of June, 2023.

---

**MAYOR – MATTHEW SHOEMAKER**

---

**CITY CLERK – RACHEL TYCZINSKI**